

Do Not Return Via Email or Fax

This is Not an Order

Mailing Address:
P. O. Box 1948
Mobile, Alabama 36633
(251) 208-7434

Purchasing Department
and Package Delivery:
Government Plaza
4th Floor, Room S-408
205 Government St
Mobile, Alabama 36644

READ TERMS AND CONDITIONS
ON REVERSE SIDE OF THIS PAGE
BEFORE BIDDING

Typed by: sd Buyer: 005

Please quote the lowest price at which you will furnish the articles listed below

Table with columns: DATE (4/20/2022), BID NO. (5673), DEPARTMENT (VARIOUS), Commodities to be delivered F.O.B. Mobile to: (As Specified)

This bid must be received and stamped by the Purchasing office not later than: 12:00 PM, Friday, May 11, 2022

Main bid table with columns: QUANTITY, ARTICLES, UNIT, UNIT PRICE (Dollars, Cents), EXTENSION (Dollars, Cents). Article: PRECAST CONCRETE POLE BASES.

RETURN ONE SIGNED COPY OF THIS BID
IN ENCLOSED ENVELOPE

State delivery time within ___ days of receipt of P.O.

Firm Name _____

Typed Signature _____

By _____

We will allow a discount ___% 20 days from date of receipt of goods
and correct invoice of completed order.

1. All quotations must be signed with the firm name and by an authorized officer or employee.
2. Verify your bid before submission as it cannot be withdrawn or corrected after being opened. In case of error in extension of prices, the unit price will govern.
3. If you do not bid, return this sheet and state reason. Otherwise, your name may be removed from our mailing list.
4. The right is reserved to reject any, or all quotations, or any portions thereof, and to waive technicalities if deemed to be in the interest of the City of Mobile.
5. This bid shall not be reassignable except by written approval of the Purchasing Agent of the City of Mobile.
6. State brand and model number of each item. All items bid must be new and latest model unless otherwise specified.
7. If bid results are desired, enclose a self-addressed and stamped envelope with your bid. (All or None bids only)
8. Do not include Federal Excise Tax as exemption certificate will be issued in lieu of same. The City is exempt from the Alabama and City sales taxes.
9. PRICES ARE TO BE FIRM AND F.O.B. DESTINATION UNLESS OTHERWISE REQUESTED.
10. BID WILL BE AWARDED ON ALL OR NONE BASIS UNLESS OTHERWISE STATED.
11. Bids received after specified time will be returned un-opened.
12. Failure to observe stated instructions and conditions will constitute grounds for rejection of your bid.
13. Furnish literature, specifications, drawings, photographs, etc., as applicable with the items bid.
14. Vendor May be required to obtain City of Mobile Business License as applicable to City of Mobile Municipal Code Section 34-50. For Business License inquiry contact the Revenue Department at (251) 208-7461 or cityofmobile.org/taxes.php.
15. If a bid bond is required in the published specifications, see below:
Each Bid Shall be Accompanied By A Cashier's Check, Certified Check, Bank Draft Or Bid Bond For the Sum Of Five (5) Percent Of The Amount Bid, Made Payable To The City Of Mobile And Certified By A Reputable Banking Institution. All Checks Shall Be Returned Promptly, Except The Check Of The Successful Bidder, Which Shall Be Returned After Fulfilling The Bid.
16. Contracts in excess of \$50,000 require that the successful bidder make every possible effort to have at least fifteen (15) percent of the total value of the contract performed by socially and economically disadvantaged individuals.
17. All bids/bid envelopes must have the bid number noted on the front. Bids that arrive unmarked and are opened in error shall be returned to vendor as an unacceptable bid.
18. If successful vendor's principal place of business is out-of-state, vendor may be required to have a Certificate of Authority to do business in the State of Alabama from the Alabama Secretary of State prior to issuance of a Purchase Order. Vendors **are solely responsible for consulting with the Secretary of State to determine whether a Certificate is required.** See www.sos.alabama.gov/BusinessServices/ForeignCorps.aspx. Please note that the time between application for and issuance of a Certificate of Authority may be several weeks.
19. Vendors do not need a City of Mobile Business License or Certificate of Authority from the Alabama Secretary of State to submit a bid, but will need to obtain the Business License and Certificate of Authority, if applicable, prior to issuance of a Purchase Order.

BID CONTINUATION SHEET

QUANTITY	ARTICLES	UNIT	UNIT PRICE		EXTENSION	
			Dollars	Cents	Dollars	Cents
	<p>PAGE 2 OF 2</p> <p>All vendors will be required to provide verification of enrollment in the E-Verify program. Additional information may be found at http://immigration.alabama.gov/</p> <p>If the successful vendor's principal place of business is out-of-state, vendor may be required to have a Certificate of Authority to do business in the State of Alabama from the Secretary of State prior to issuance of a Purchase Order.</p> <p>Vendors are solely responsible for consulting with the Secretary of State to determine whether a Certificate is required. See: www.sos.alabama.gov/BusinessServices/ForeignCorps.aspx. Please note that the time between application for the issuance of a Certificate of Authority may be several weeks.</p> <p>Upon notification, vendor will have 10 business days to provide the Certificate of Authority and the E-Verify numbers to the Purchasing Department before award can be completed. (Vendors will possibly need to pay the expedite fee to meet this requirement because application is not sufficient. We must have a copy of the certificate with your Company ID number).</p> <p>Vendors do not need a City of Mobile Business License or Certificate of Authority from the Alabama Secretary of State, nor the E-Verify for certification to submit a bid, but will need to obtain the Business License and Certificate of Authority verification and/or provide the E-Verify Certification, if applicable, prior to issuance of a Purchase Order.</p> <p>All prices quoted are to be delivered prices F. O. B. Mobile. The City of Mobile Business License is required. See item 14 on reverse side of page 1.</p> <p>State of Alabama Local Vendor Preference Law 41-16-50 (a) and (d) will apply to this purchase. See reverse side of page 1 of Bid for instructions and conditions.</p> <p>If you have any questions, please feel free to contact the Purchasing Department at 251-208-7434 or purchasing@cityofmobile.org.</p> <p>THIS BID TO BE AWARDED ALL OR NONE</p>					
			TOTAL			

RETURN ONE SIGNED COPY OF THIS QUOTATION IN ENCLOSED ENVELOPE

READ ABOVE INSTRUCTIONS BEFORE QUOTING

Firm Name _____

By _____

We will allow a discount _____ % 20 days from date of receipt of goods and correct invoice of completed order.

PRECAST LIGHT POLE FOUNDATION

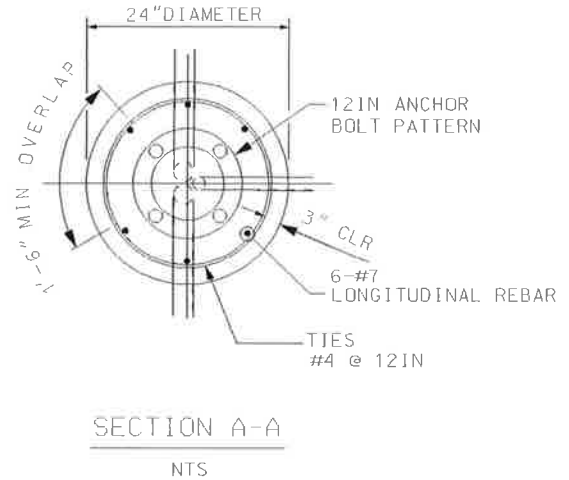
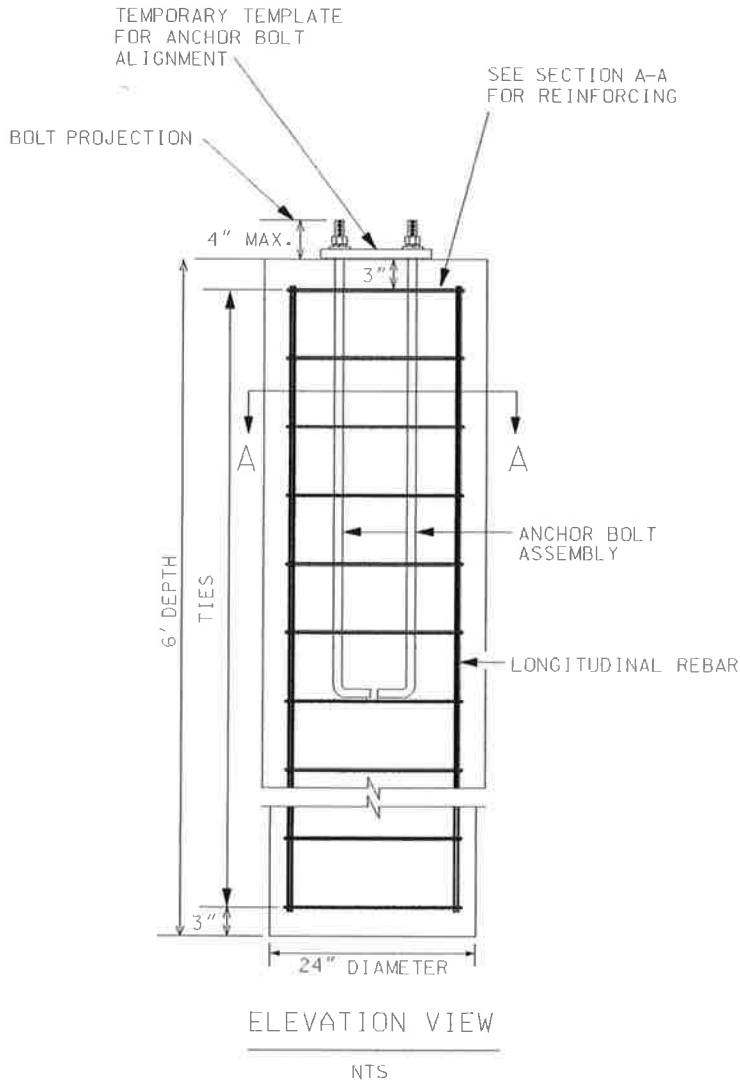

PRECAST CONCRETE FOUNDATION NOTES:

- (1) CONCRETE SHALL BE CLASS A AND SHALL MEET STANDARDS AS PROVIDED IN SECTION 501 OF THE ALDOT STANDARD SPECIFICATIONS FOR HIGHWAY CONSTRUCTION.
- (2) TOP OF FOUNDATION SHALL BE FINISHED WITH 1 INCH CHAMFERED EDGE.
- (3) PRECAST FOUNDATION MUST ORIGINATE FROM A NPCA OR PCI CERTIFIED PLANT.
- (4) PRECAST FOUNDATION SHALL INCLUDE THREE CONDUITS AS ILLUSTRATED IN SECTION A-A. TWO SHALL BE 2 INCH PVC ORIENTED AT 0 AND 180 DEGREES. ONE SHALL BE 1 INCH PVC ORIENTED AT 90 DEGREES. ALL THREE CONDUITS SHALL EXTEND INTO THE FOUNDATION NO LESS THAN 2 FEET AND NO MORE THAN 4 FEET. ALL CONDUIT SHALL BEND 90 DEGREES AND EXTEND OUTWARD FROM THE SIDE WITH A 9.5 INCH RADIUS ELBOW FOR THE 2 INCH CONDUIT AND 5.75 INCH RADIUS FOR THE 1 INCH CONDUIT. ALL CONDUIT SHALL EXTEND FROM THE TOP AND SIDES OF THE FOUNDATION BY AT LEAST 3.5 INCH.
- (5) ANCHOR BOLT TEMPLATE SHALL BE FOR A 8.5 INCH X 8.5 INCH, 12 INCH ANCHOR BOLT CIRCLE. ANCHOR BOLTS SHALL BE 1 INCH DIAMETER BY 36 INCH LONG L-SHAPED EACH COMPLETE WITH FLAT WASHER AND NUT.
- (6) REINFORCING SHALL BE AS ILLUSTRATED IN SECTION A-A.



PROCUREMENT DEPARTMENT

Potential bidders are responsible to check this site for any **ADDENDUMS** that are issued. It is the responsibility of the **BIDDER** to check for, download, and include with their **BID RESPONSE** any and all **ADDENDUMS** that are issued for a specific **BID** published by the City of Mobile. Failure to download and include **ADDENDUMS** in your **BID RESPONSE** may cause your bid to be rejected.

This is a sealed bid. Any responses faxed or e-mailed will be rejected.

This is a sealed bid. Any response must be submitted in a sealed envelope With the bid number and bid opening date on the outside of the envelope.

Any response that arrives improperly marked or with no bid number and Opening date on the outside of the delivery or express package and opened in error will be rejected and not considered.

It is the responsibility of the bidder to ensure that their bid response is delivered to and received in the Purchasing Department before the date and time of the bid opening.

Be sure to read the Terms and Conditions. All bids are F.O.B. Destination unless otherwise stated.

Be sure to sign your bid!

Package/Bid Delivery Address:
Purchasing Department
205 Government St. Room S408
Mobile, AL 36644

(Request First Delivery)