

Do Not Return Via Email or Fax

This is Not an Order

Mailing Address:
P. O. Box 1948
Mobile, Alabama 36633
(251) 208-7434

Purchasing Department
and Package Delivery:
Government Plaza
4th Floor, Room S-408
205 Government St
Mobile, Alabama 36644

READ TERMS AND CONDITIONS
ON REVERSE SIDE OF THIS PAGE
BEFORE BIDDING

Typed by: sd Buyer: 005

Please quote the lowest price at which you will furnish the articles listed below

Table with 4 columns: DATE (07/21/2022), BID NO. (5710), DEPARTMENT (Traffic Engineering), and Commodities to be delivered F.O.B. Mobile to: (To Be Specified)

This bid must be received and stamped by the Purchasing office not later than: 12:00 PM, Friday, August 12, 2022

Main bid table with columns: QUANTITY (Qty 5-20), ARTICLES (AREA LIGHTING DECORATIVE ALUMINUM POLE ASSEMBLY), UNIT, UNIT PRICE (Dollars, Cents), and EXTENSION (Dollars, Cents). Includes detailed specifications for the pole assembly.

TOTAL

RETURN ONE SIGNED COPY OF THIS BID
IN ENCLOSED ENVELOPE

State delivery time within \_\_\_ days of receipt of P.O.

Firm Name \_\_\_\_\_

Typed Signature \_\_\_\_\_

By \_\_\_\_\_

We will allow a discount \_\_\_% 20 days from date of receipt of goods
and correct invoice of completed order.

1. All quotations must be signed with the firm name and by an authorized officer or employee.
2. Verify your bid before submission as it cannot be withdrawn or corrected after being opened. In case of error in extension of prices, the unit price will govern.
3. If you do not bid, return this sheet and state reason. Otherwise, your name may be removed from our mailing list.
4. The right is reserved to reject any, or all quotations, or any portions thereof, and to waive technicalities if deemed to be in the interest of the City of Mobile.
5. This bid shall not be reassignable except by written approval of the Purchasing Agent of the City of Mobile.
6. State brand and model number of each item. All items bid must be new and latest model unless otherwise specified.
7. If bid results are desired, enclose a self-addressed and stamped envelope with your bid. (All or None bids only)
8. Do not include Federal Excise Tax as exemption certificate will be issued in lieu of same. The City is exempt from the Alabama and City sales taxes.
9. PRICES ARE TO BE FIRM AND F.O.B. DESTINATION UNLESS OTHERWISE REQUESTED.
10. BID WILL BE AWARDED ON ALL OR NONE BASIS UNLESS OTHERWISE STATED.
11. Bids received after specified time will be returned un-opened.
12. Failure to observe stated instructions and conditions will constitute grounds for rejection of your bid.
13. Furnish literature, specifications, drawings, photographs, etc., as applicable with the items bid.
14. Vendor May be required to obtain City of Mobile Business License as applicable to City of Mobile Municipal Code Section 34-50. For Business License inquiry contact the Revenue Department at (251) 208-7461 or [cityofmobile.org/taxes.php](http://cityofmobile.org/taxes.php).
15. If a bid bond is required in the published specifications, see below:  
**Each Bid Shall be Accompanied By A Cashier's Check, Certified Check, Bank Draft Or Bid Bond For the Sum Of Five (5) Percent Of The Amount Bid, Made Payable To The City Of Mobile And Certified By A Reputable Banking Institution. All Checks Shall Be Returned Promptly, Except The Check Of The Successful Bidder, Which Shall Be Returned After Fulfilling The Bid.**
16. Contracts in excess of \$50,000 require that the successful bidder **make every possible effort** to have at least fifteen (15) percent of the total value of the contract performed by socially and **economically disadvantaged** individuals.
17. All bids/bid envelopes must have the bid number noted on the front. Bids that arrive unmarked and are opened in error shall be returned to vendor as an unacceptable bid.
18. If successful vendor's principal place of business is out-of-state, vendor may be required to have a Certificate of Authority to do business in the State of Alabama from the Alabama Secretary of State prior to issuance of a Purchase Order. Vendors **are solely responsible for consulting with the Secretary of State** to determine whether a Certificate is required. See [www.sos.alabama.gov/BusinessServices/ForeignCorps.aspx](http://www.sos.alabama.gov/BusinessServices/ForeignCorps.aspx). Please note that the time between application for and issuance of a Certificate of Authority may be several weeks.
19. Vendors do not need a City of Mobile Business License or Certificate of Authority from the Alabama Secretary of State to submit a bid, but will need to obtain the Business License and Certificate of Authority, if applicable, prior to issuance of a Purchase Order.

## BID CONTINUATION SHEET

| QUANTITY | ARTICLES   | UNIT | UNIT PRICE   |       | EXTENSION |       |
|----------|--|------|--------------|-------|-----------|-------|
|          |  |      | Dollars      | Cents | Dollars   | Cents |
|          | <p>Page 2 of 2</p> <p>All vendors will be required to provide verification of enrollment in the E-Verify program. Additional information may be found at <a href="http://immigration.alabama.gov/">http://immigration.alabama.gov/</a></p> <p>If the successful vendor's principal place of business is out-of-state, vendor may be required to have a Certificate of Authority to do business in the State of Alabama from the Secretary of State prior to issuance of a Purchase Order.</p> <p>Vendors are solely responsible for consulting with the Secretary of State to determine whether a Certificate is required.<br/>See: <a href="http://www.sos.alabama.gov/BusinessServices/ForeignCorps.aspx">www.sos.alabama.gov/BusinessServices/ForeignCorps.aspx</a>.<br/>Please note that the time between application for the issuance of a Certificate of Authority may be several weeks.</p> <p>Upon notification, vendor will have 10 business days to provide the Certificate of Authority and the E-Verify numbers to the Purchasing Department before award can be completed.<br/>(Vendors will possibly need to pay the expedite fee to meet this requirement because application is not sufficient. We must have a copy of the certificate with your Company ID number).</p> <p>Vendors do not need a City of Mobile Business License or Certificate of Authority from the Alabama Secretary of State, nor the E-Verify for certification to submit a bid, but will need to obtain the Business License and Certificate of Authority verification and/or provide the E-Verify Certification, if applicable, prior to issuance of a Purchase Order.</p> <p>State of Alabama Local Vendor Preference Law 41-16-50 (a) and (d) will apply to this purchase.</p> <p>See reverse side of page 1 of Bid for instructions and conditions.</p> <p><b>If you have any questions, please feel free to contact the Purchasing Department at 251-208-7434 or <a href="mailto:purchasing@cityofmobile.org">purchasing@cityofmobile.org</a>.</b></p> <p><b>VENDOR MUST HAVE CONTACT INFORMATION WITH THIS BID.</b></p> <p><b>TO BE AWARDED ON AN ITEM BASIS.</b></p> |      |              |       |           |       |
|          |  |      | <b>TOTAL</b> |       |           |       |

**RETURN ONE SIGNED COPY OF THIS QUOTATION IN ENCLOSED ENVELOPE**

**READ ABOVE INSTRUCTIONS BEFORE QUOTING**

Firm Name \_\_\_\_\_

By \_\_\_\_\_

We will allow a discount \_\_\_\_\_% 20 days from date of receipt of goods and correct invoice of competed order.

**CITY OF MOBILE**  
**SPECIFICATIONS FOR ROADWAY LIGHT POLE & LUMINAIRE**  
**Village of Spring Hill Standards**  
**July 2022**

**I. General.**

The following are the requirements for aluminum roadway light pole and luminaire to meet the standards established within the Village of Spring Hill. The light pole shall consist of a fluted, tapered pole with welded decorative base, anchor bolts, base plate, and any other features as described in this specification. The luminaire shall be a spun aluminum shade pendant style fixture with a polycarbonate drop lens. The luminaire arm shall be a shepherd hook style aluminum arm.

**II. Design/Fabrication.**

All materials used in the fabrication of roadway light poles shall meet the requirements of the AASHTO Standard Specifications for Structural Supports for Highway Signs, Luminaires and Traffic Signals, 2009 edition as per the latest ALDOT Standard Specifications.

**(a.) Aluminum Pole.**

The pole shall consist of round, 12-fluted, and tapered shaft manufactured with cast or extruded 6061-T6 aluminum. The decorative base shall be cast A356 aluminum and welded to the pole shaft. The pole shall include a 4-inch outside diameter by 3-inch tall tenon cast of A356 aluminum.

The aluminum pole shall be 12-feet in height with a nominal 17-inch outside bottom diameter at the base. Shaft shall range from 6-inch at the bottom to 4-inch at top of shaft. The nominal wall thickness shall be between 0.125 to 0.188 inches. The pole shall include a 4-inch by 5-inch curved hand hole with aluminum cover and two stainless steel screws and bolts for fastening to the pole. Each pole will have an internal grounding lug.

The aluminum base plate of the pole shall be designed with four equally spaced openings to accommodate a bolt circle pattern ranging from 11 inches to 14 inches.

**(b.) Luminaire.**

The luminaire shall be a decorative pendant consisting of a decorative cast aluminum fitter, a heavy gauge spun aluminum shade and inverted acorn shaped lens. The clear textured polycarbonate lens shall extend 3-inch from the shade. The luminaire shall be a 150 W metal halide fixture, designed for 240 voltage and a Type V light distribution. The overall fixture height shall measure 27-inches and the diameter of the shade shall be 20-inch. The shade shall be finished textured black.

**(c.) Luminaire Arm.**

Luminaire arm shall be 47-inch tall and 25-inch wide shepherd hook style round shaft. The luminaire arm shall be manufactured from 1 1/2-inch Schedule 40 aluminum pipe finished textured black. The arm shall be designed with a cast aluminum slip fitter welded to attach to the outside of the pole tenon with six 5/16-inch stainless steel set screws. The arm shall have a cast aluminum fitter welded to the top of the arm for attaching the pendent fixture with three 5/16-inch stainless steel set screws. Arm shall be prewired with a quick connect for easy installation.

**(d.) Anchor Bolt Assemblies.**

Pole shall come complete with four 1/2-inch x 18-inch L-type anchor bolts with 3" horizontal bend manufactured of hot-dipped galvanized steel. Anchor bolt assembly shall also include two nuts and two washers per bolt.

Anchor bolt assemblies (anchor bolts, nuts, and washers) shall be in accordance with AASHTO M 314, Grade 36 or Grade 55, except maximum tensile strength on all grades is waived, and capable of transferring the load safely from the structure base plate to the foundation. The exposed end of the anchor bolts shall be threaded (rolled or cut type) and provided with appropriate nuts, including lock nuts and flat washers. The anchor bolts, nuts, and washers shall be hot-dipped galvanized in accordance with AASHTO M 232, however, galvanization of the bolt below 6 inches from the top of the embedment line will not be required. The nuts shall be lubricated with a lubricant containing a visible dye so that a visual check can be made for proper lubrication prior to installation. Special care shall be taken when storing galvanized bolts with a water-soluble lubricant.

**(e.) Additional Features.**

The pole shall include a GFCI receptacle with in-use weather-proof cover 6 inches from top of pole. Cover shall be aluminum and finished textured black to match the pole. Orientation shall be zero degrees from access door.

**(f.) Finish.**

Pole and luminaire arm shall be hot dipped galvanized per ASTM-A123. Powered coating finish or approved equivalent is required, and the finished color shall be textured black. Material shall be wrapped and protected to prevent damage during shipping, storage and construction.

**Example Illustrations.**

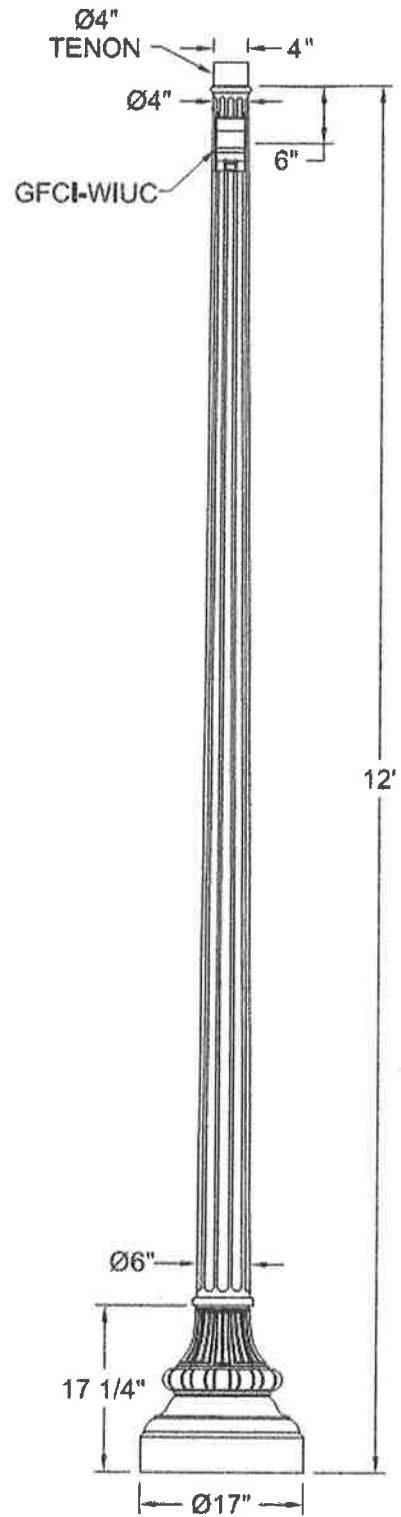
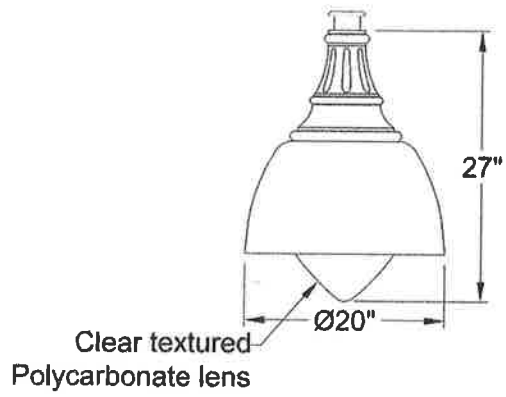
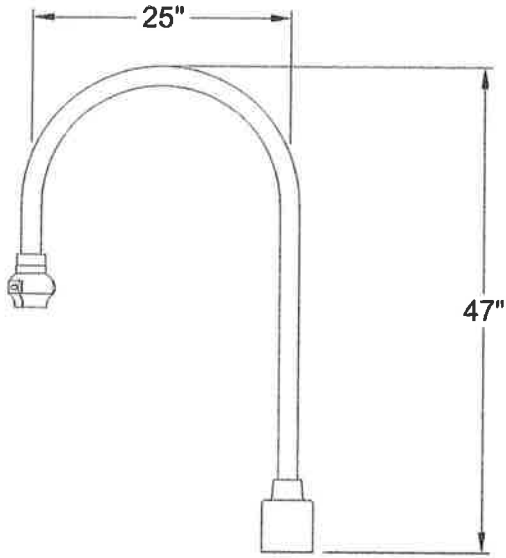



## **PROCUREMENT DEPARTMENT**

**Potential bidders are responsible to check this site for any ADDENDUMS that are issued. It is the responsibility of the BIDDER to check for, download, and include with their BID RESPONSE any and all ADDENDUMS that are issued for a specific BID published by the City of Mobile. Failure to download and include ADDENDUMS in your BID RESPONSE may cause your bid to be rejected.**

**This is a sealed bid. Any responses faxed or e-mailed will be rejected.**

**This is a sealed bid. Any response must be submitted in a sealed envelope with the bid number and bid opening date on the outside of the envelope.**

**Any response that arrives improperly marked or with no bid number and opening date on the outside of the delivery or express package and opened in error will be rejected and not considered.**

**It is the responsibility of the bidder to ensure that their bid response is delivered to and received in the Purchasing Department before the date and time of the bid opening.**

**Be sure to read the Terms and Conditions.  
All bids are F.O.B. destination unless otherwise stated.**

**Be sure to sign your bid!**

**Package/Bid Delivery Address:  
Purchasing Department  
205 Government St. Room S408  
Mobile, AL 36644**

**(Request First Delivery)**