

ADVERTISEMENT FOR BIDS

Crichton Fire Station – Drive Repair
200 Davenport Ave.
Mobile, Alabama 36607
FD-072-21

Notice is hereby given that the City of Mobile will receive sealed bids for the above stated project on **Wednesday, February 23, 2022, until 2:15 pm local time**. Bidders shall insert sealed Bids into a receptacle, marked “City of Mobile Bids”, located in the elevator lobby outside the office of the City Clerk Office, 9th Floor South Tower, Government Plaza, 205 Government Street, Mobile, Alabama 36602. The same will be publicly opened and read at 2:30 PM in the Atrium Lobby of Government Plaza. Additional bidding instructions are detailed in the project manual.

A **pre-bid conference** will be held at the Project Site at **9:00 am local time on Wednesday, February 9, 2022**. Social distancing practices shall be observed, including wearing of face coverings/masks by all participants. A representative of the Bidder is encouraged to be present at the meeting. However, if no representative can be present in person, the Bidder shall contact the Capital Improvement Project Manager at (251) 208-7637, at least 24 hours prior to the meeting, in order to coordinate attendance of the meeting by conference call. Bidders are required to visit the Project Site prior to submitting a Bid and include all costs associated with the project in their Bids.

For information on obtaining plans, specifications, and contract documents go to:
www.cityofmobile.org/bids/

Disadvantaged Business Enterprise participation may be required. A Directory of DBE Vendors can be found at the following location: **<https://workwith.cityofmobile.org/>**

For questions regarding this project, please contact City of Mobile Capital Improvement Project Manager **David Cordingly** at **(251) 208-7637** or **david.cordingly@cityofmobile.org**.



PROJECT MANUAL

CRICHTON FIRE STATION – DRIVE REPAIR

200 Davenport Ave., Mobile, Alabama 36607

Project # FD-072-21

Issued – February 4, 2022

**City of Mobile, Alabama
Architectural Engineering Department
P. O. Box 1827
Mobile, AL 36633-1827
(251) 208-7454**

And

Watermark Design Group, LLC



watermark
DESIGN

TABLE OF CONTENTS

TABLE OF CONTENTS

PROFESSIONAL SEALS PAGE

BIDDING AND CONTRACT REQUIREMENTS AND FORMS:

00100 INVITATION TO BID 4

00200 INSTRUCTIONS TO BIDDERS
AIA Document A701 9

00300 SUPPLEMENTAL INSTRUCTIONS TO BIDDERS 6

00410 BID FORM 3

SUPPLIER DIVERSITY SUBCONTRACTING & MAJOR SUPPLIER PLAN..... 5

00415 ACCOUNTING OF SALES TAX FORM C-3A..... 1

00500 STANDARD FORM OF AGREEMENT BETWEEN OWNER & CONTRACTOR
AIA Document A101 - 2017 (City of Mobile Revisions) 14

00600 BONDS, CERTIFICATES AND AFFIDAVITS

PERFORMANCE BOND 1

LABOR AND MATERIAL PAYMENT BOND 1

E-VERIFY MEMORANDUM OF UNDERSTANDING (Sample)..... 17

APPLICATION AND CERTIFICATION FOR PAYMENT - AIA Document G702 and AIA Document G703 2

DBE UTILIZATION REPORT 1

CERTIFICATE of SUBSTANTIAL COMPLETION – AIA Document G704-2017 1

CONTRACTOR'S AFFIDAVIT OF PAYMENT OF DEBTS AND CLAIMS - AIA Document G706 1

CONTRACTOR'S AFFIDAVIT OF RELEASE OF LIENS - AIA Document G706A 1

CONSENT OF SURETY TO FINAL PAYMENT - AIA Document G707..... 1

CITY OF MOBILE VENDOR INFORMATION FORM 2

00700 GENERAL CONDITIONS OF THE CONTRACT FOR CONSTRUCTION
AIA Document A201 - 2007 (City of Mobile Revisions) 44

GENERAL REQUIREMENTS AND TECHNICAL SPECIFICATIONS:

DIVISION 01 - GENERAL REQUIREMENTS

011000 SUMMARY 2
012100 ALLOWANCES 2
012200 UNIT PRICES 1
014000 QUALITY REQUIREMENTS 5
015000 TEMPORARY FACILITIES AND CONTROLS 2
016000 PRODUCT REQUIREMENTS 6

DIVISION 02 - EXISTING CONDITIONS

022200 SELECTIVE DEMOLITION 2

DIVISION 03 - CONCRETE NOT USED

DIVISION 04 - MASONRY NOT USED

DIVISION 05 - METALS NOT USED

DIVISION 06 - WOOD, PLASTICS, AND COMPOSITES NOT USED

DIVISION 07 - THERMAL AND MOISTURE PROTECTION NOT USED

DIVISION 08 - OPENINGS NOT USED

DIVISION 09 - FINISHES NOT USED

DIVISION 10 - SPECIALTIES NOT USED

DIVISION 11 - EQUIPMENT NOT USED

DIVISION 12 - FURNISHINGS NOT USED

DIVISION 13 – SPECIAL CONSTRUCTION NOT USED

DIVISION 21 – FIRE PROTECTION NOT USED

DIVISION 22 – PLUMBING NOT USED

DIVISION 23 – HEATING, VENTILATING AND AIR CONDITIONING NOT USED

DIVISION 26 – ELECTRICAL NOT USED

DIVISION 27 – TELECOMMUNICATIONS NOT USED

DIVISION 22 - PLUMBING (infrastructure) NOT USED

DIVISION 31 - EARTHWORK NOT USED

DIVISION 32 - EXTERIOR IMPROVEMENTS

321613 CONCRETE SIDEWALK AND CURBS 7

DIVISION 33 - UTILITIES NOT USED

END OF TABLE OF CONTENTS

PROFESSIONAL SEALS



ARCHITECT



CIVIL

STRUCTURAL

FIRE PROTECTION

MECHANICAL

ELECTRICAL

SECTION 00100 - INVITATION TO BID

You are invited to submit a sealed bid for construction of the following facility:

PROJECT NAME: **Crichton Fire station – Drive Repairs**

PROJECT LOCATION: 200 Davenport Ave.
Mobile, Alabama 36607

PROJECT NUMBER: FD-072-21

1 BID DATE:

- A. Sealed Bids will be received and clocked in until 2:15 p.m. local time, Wednesday, the 16th day of February 2022. Bidders shall insert sealed Bids into a receptacle, marked “City of Mobile Bids”, located in the elevator lobby outside the office of the City Clerk, 9th Floor South Tower, Government Plaza, 205 Government Street, Mobile, Alabama.
- B. All Bids not clocked in at the City Clerk’s Office prior to the time specified, or Bids received after the specified time, will be automatically rejected, and returned immediately, unopened.
- C. Bids will be publicly opened and read at 2:30 p.m. local time, on February 16, 2022, in the Atrium Lobby of Government Plaza.

2 SPECIFICATIONS AND DRAWINGS:

- A. Specifications and Drawings are on file and may be examined at the following location:
 - a. www.cityofmobile.org/bids/
 - b. Watermark Design Group, LLC, 2970 Cottage Hill Road, Suite 200, Mobile Alabama 36606
 - c. For information regarding this project contact Sandy McArthur, Watermark Design Group, 251-378-6175, smcarthur@watermarkarch.com
- B. Bidders shall use complete sets of Bid Documents in preparing their bid. The City of Mobile will not assume responsibility for errors or misinterpretations resulting from the use of incomplete sets of Bid Documents.
- C. Addenda will be issued only to registered bidders. Bidders shall use a complete set of Bid Documents, including all Addenda, in preparing their bid. Neither the Owner, the Architect, nor the AE Department assumes responsibility for errors or misinterpretations resulting from the use of incomplete sets of Bid Documents.
- D. This is a tax-exempt project and shall be certified by the requirements of the Alabama Department of Revenue. **Bidders shall NOT include sales taxes and use taxes with their bid amounts.** Bidders shall complete the Sales Tax Form C-3A and include it as an attachment to their bid form (See Section 00410).
- E. Product Substitutions must be pre-approved before the bid.

3 BID SURETY: Required on Bids \$10,000.00 or more

- A. A Cashier’s Check drawn on a bank registered to do business in the State of Alabama, and which is a member of the Federal Deposit Insurance Corporation or Bid Bond payable to Owner, City of Mobile, in the amount of 5% of the Base Bid, but in no event more than \$10,000.00, must accompany your Bid.

- B. Bid Bond must be issued by a Surety licensed to do business in the State of Alabama. Bidder shall require the attorney in fact who executes the required bonds on behalf of the surety to affix the bond a certified and current copy of the power of attorney.
 - C. No Bid may be modified, withdrawn, or canceled for a period of sixty (60) days after the time designated for receipt of bids.
 - D. The City of Mobile will have sixty (60) days from the bid opening date to award a contract.
- 4 SURETY QUALIFICATIONS:
- A. A Surety authorized to do business in the State of Alabama must issue Bonds.
 - B. If the Base Bid is \$50,000 or more, the Surety must have a minimum rating of A/Class VI as reported by the latest issue of Best Key Rating Guide Property-Casualty published by Alfred M. Best Company, Inc.
- 5 IRREGULARITIES AND REJECTION:
- A. The City of Mobile reserves the right to waive irregularities in the Bid and in Bidding, and to reject any or all Bids.
- 6 BIDDER QUALIFICATIONS:
- A. Bids for Work costing \$50,000 or more must be licensed pursuant to current Alabama law and of classifications compliant with the State of Alabama Licensing Board for General Contractors. Note that if the contract amount is \$10,000 or greater, both a Performance Bond and a Labor and Material Payment Bond shall be required. **Before Bidding, Contractor shall verify their license classification of their General Contractors license with the State of Alabama Licensing Board for General Contractors to verify classification is acceptable to perform 51% of the Scope of Work.**
 - B. In case of a joint venture of two or more Contractors, the amount for the bid shall be within the maximum bid limitations as set by the State Licensing Board for General Contractors of at least one of the partners to the joint venture.
- 7 NON-RESIDENT CONTRACTORS:
- A. Except for contracts funded in whole or part with funds received from a federal agency, preference shall be given to resident Contractors on the same basis as the nonresident Contractor's state awards contracts to Alabama Contractors bidding in similar circumstances.
 - B. Nonresident Bidders shall, prior to submitting a bid, be registered with the Alabama Secretary of State and the Alabama Department of Revenue. Provide the Secretary of State Business "Entity ID Number" on the Bid Form in the space provided.
- 8 PRE-BID CONFERENCE:
- A. A Pre-Bid Conference shall be held at the Project Site located at 200 Davenport Ave., Mobile, Alabama 36607 at 9:00 AM local time on Wednesday, February 9, 2022.
 - B. Virtual attendance is acceptable. Call David Cordingly, 251-208-7637 at least 24 hours in advance for information related to conference call.
 - C. Those attending will have an opportunity to inspect the site. Bidders and their subcontractors or employees must inspect the site at their own risk.

- D. Minutes of this conference and a roster of attendees will be issued as an Addendum for the project to registered Bidders and those in attendance at the Pre-Bid Conference.

9 BID SUBMITTAL:

- A. Bids must be submitted on copies of the Bid Forms furnished in this Project Manual. Bidders are encouraged to copy the Bid Form in the Project Manual for bid submission.
- B. Bid, with Bid Security, Sales Tax Form C-3A, City of Mobile Subcontracting & Major Supplier Plan and other supporting data specified, shall be contained in a sealed, opaque envelope, approximately 9x12 inches or larger and be marked on the outside with the words "SEALED BID FOR CRICHTON FIRE STATION – DRIVE REPAIR: PROJECT NO. FD-072-21".
- C. The Bid envelope shall be clearly addressed to the City of Mobile as indicated on the Bid Form and shall include the bid date, the name, address and State License number and classification of the Bidder issued by the State of Alabama Licensing Board for General Contractors.
- D. All Bids of \$50,000 or more must be accompanied by a copy of the bidder's Alabama General Contractor's License number and classification clearly indicated on the outside of the bid envelope. Any bid submitted without such a license number may be rejected and returned to the bidder unopened.
- E. In addition, in large letters on both front and back of envelope, write the following: DO NOT OPEN UNTIL TWO-THIRTY PM, February 16, 2022.
- F. For a bid to be valid it shall be delivered at designated location prior to time and date for receipt of Bids indicated in INVITATION TO BID, or prior to any extension thereof issued to Bidders. After that time no Bid will be received or withdrawn.
- G. When sent by mail, preferably special delivery, express service, or registered mail, the sealed Bid, marked as indicated above, shall be enclosed in another envelope for mailing such that the exterior mailing container or envelope may be opened without revealing the contents of the Bid. **It is the Contractors responsibility to assure delivery of the bid to the City Clerk's office prior to the time and date established.**

10 EQUAL OPPORTUNITY:

- A. The City of Mobile, Alabama is an Equal Opportunity Employer and requires that all Contractors comply with the Equal Employment Opportunity laws and the provisions of the Bid Documents in this regard.
- B. The City of Mobile also encourages and supports the utilization of Minority Business Enterprises on these and all other publicly solicited Bids and shall be in compliance with the City of Mobile's Minority Utilization Plan as adopted by the City Council.
- C. Contractor shall provide an appropriately completed copy of the "City of Mobile Subcontracting and Major Supplier Plan" in the envelope with their Bid Form. Failure to submit forms is an automatic bid rejection. Form shall document DBE Subcontractors participating in the project and, should the total % of DBE participation not meet the 15% minimum, all efforts to obtain DBE Subcontractors shall be documented on or attached to the DBE Form when submitted. During construction, contractors are required to submit a "DBE Utilization Report" with every Pay Application Failure to submit Utilization Report with Pay Application will result in return of Pay Application without action.

- D. Contractors should contact the City of Mobile, Supplier Diversity Manager for assistance with DBE Subcontractor information and any questions regarding the DBE Compliance Forms. Contact Archnique Kidd by email at archnique.kidd@cityofmobile.org.
- E. A listing of DBE Vendors is located at <https://workwith.cityofmobile.org>

11 ADDITIONAL BIDDING PROCEDURES:

- A. Refer to the complete information in the Bid Documents prior to submitting a bid. Additional Bidding Procedure information is contained therein, particularly in the specification Section 00200 “Instructions to Bidders - AIA Document A701” and in the specification Section 00300 “Supplementary Instructions to Bidders”.

12 STATE OF ALABAMA IMMIGRATION ACT

- A. “The State of Alabama, under the Beason-Hammon Alabama Taxpayer and Citizen Protection Act, Act No. 2011-535, Alabama Code Section 31-13-1, et. Seq., requires:
- B. That the Contractor shall be enrolled in the E-Verify Program, shall participate in that Program during the performance of the contract, and shall verify the immigration status of every employee who is required to be verified, according to the applicable federal rules and regulations; and that it will attach to the contract the company’s documentation of enrollment in E-Verify.
- C. The subcontractor must also enroll in the E-Verify Program prior to performing any work on the contract and shall attach to its sworn affidavit documentation establishing that the subcontractor is enrolled in the E-Verify Program.

13 PUBLIC CONTRACTS WITH ENTITIES ENGAGING IN CERTAIN BOYCOTT ACTIVITIES

- A. By signing this contract, Contractor further represents and agrees that it is not currently engaged in, nor will it engage in, any boycott of a person or entity based in or doing business with a jurisdiction with which the State of Alabama can enjoy open trade

END OF SECTION

SECTION 00200 - INSTRUCTIONS TO BIDDERS

PART 1 GENERAL

- A. This section includes the INSTRUCTIONS TO BIDDERS, AIA Document A701-2018 to be utilized with the Owner's most recent modifications and which shall be used in conjunction with the entire Bid Documents and Section 00300 Supplemental Instructions to Bidders for this project.

AIA Document A701™ – 2018

Instructions to Bidders

for the following Project:

(Name, location, and detailed description)

CRICHTON FIRE STATION - DRIVE REPAIR
200 Davenport Avenue
Mobile, Alabama 36607
FD-072-21

THE OWNER:

(Name, legal status, address, and other information)

City of Mobile
PO Box 1827
Mobile, Alabama 36633-1827

THE ARCHITECT:

(Name, legal status, address, and other information)

Watermark Design Group, LLC
2970 Cottage Hill Road, Suite 200
Mobile, Alabama 36606

TABLE OF ARTICLES

1	DEFINITIONS
2	BIDDER'S REPRESENTATIONS
3	BIDDING DOCUMENTS
4	BIDDING PROCEDURES
5	CONSIDERATION OF BIDS
6	POST-BID INFORMATION
7	PERFORMANCE BOND AND PAYMENT BOND
8	FORM OF AGREEMENT BETWEEN OWNER AND CONTRACTOR
9	NONDISCRIMINATION
10	USE OF DOMESTIC PRODUCTS
11	PREFERENCE TO RESIDENT CONTRACTORS
12	PRE-BID REQUIREMENTS

ADDITIONS AND DELETIONS:

The author of this document has added information needed for its completion. The author may also have revised the text of the original AIA standard form. An *Additions and Deletions Report* that notes added information as well as revisions to the standard form text is available from the author and should be reviewed. A vertical line in the left margin of this document indicates where the author has added necessary information and where the author has added to or deleted from the original AIA text.

This document has important legal consequences. Consultation with an attorney is encouraged with respect to its completion or modification.

FEDERAL, STATE, AND LOCAL LAWS MAY IMPOSE REQUIREMENTS ON PUBLIC PROCUREMENT CONTRACTS. CONSULT LOCAL AUTHORITIES OR AN ATTORNEY TO VERIFY REQUIREMENTS APPLICABLE TO THIS PROCUREMENT BEFORE COMPLETING THIS FORM.

It is intended that AIA Document G612™-2017, Owner's Instructions to the Architect, Parts A and B will be completed prior to using this document.

ARTICLE 1 DEFINITIONS

§ 1.1 Bidding Documents include the Bidding Requirements and the Proposed Contract Documents. The Bidding Requirements consist of the advertisement or invitation to bid, Instructions to Bidders, supplementary instructions to bidders, the bid form, and any other bidding forms. The Proposed Contract Documents consist of the unexecuted form of Agreement between the Owner and Contractor and that Agreement's Exhibits, Conditions of the Contract (General, Supplementary and other Conditions), Drawings, Specifications, all Addenda, and all other documents enumerated in Article 8 of these Instructions.

§ 1.2 Definitions set forth in the General Conditions of the Contract for Construction, or in other Proposed Contract Documents apply to the Bidding Documents.

§ 1.3 Addenda are written or graphic instruments issued by the Architect, which, by additions, deletions, clarifications, or corrections, modify or interpret the Bidding Documents.

§ 1.4 A Bid is a complete and properly executed proposal to do the Work for the sums stipulated therein, submitted in accordance with the Bidding Documents.

§ 1.5 The Base Bid is the sum stated in the Bid for which the Bidder offers to perform the Work described in the Bidding Documents, to which Work may be added or deleted by sums stated in Alternate Bids.

§ 1.6 An Alternate Bid (or Alternate) is an amount stated in the Bid to be added to or deducted from, or that does not change, the Base Bid if the corresponding change in the Work, as described in the Bidding Documents, is accepted.

§ 1.7 A Unit Price is an amount stated in the Bid as a price per unit of measurement for materials, equipment, or services, or a portion of the Work, as described in the Bidding Documents.

§ 1.8 A Bidder is a person or entity who submits a Bid and who meets the requirements set forth in the Bidding Documents. A Bidder must be licensed by the State Licensing Board for General Contractors if the amount for the Contract exceeds the amount established by said Board.

§ 1.9 A Sub-bidder is a person or entity who submits a bid to a Bidder for materials, equipment, or labor for a portion of the Work. A Sub-bidder performing Work must be licensed by the State Licensing Board for General Contractors if the Sub-bidders' contract amount exceeds that established by said Board.

- 1.10 A non-resident Bidder or Sub-bidder is one who
- a. Is neither organized nor existing under the laws of the State of Alabama
 - b. nor maintains its principal place of business in the State of Alabama.

A non-resident contractor who has maintained a permanent branch office within the State of Alabama for at least five (5) continuous years shall not thereafter be deemed to be a non-resident contractor so long as such contractor continues to maintain a branch office within Alabama.

ARTICLE 2 BIDDER'S REPRESENTATIONS

§ 2.1 By submitting a Bid, the Bidder represents that:

- .1 the Bidder has read and understands the Bidding Documents;
- .2 the Bidder understands how the Bidding Documents relate to other portions of the Project, if any, being bid concurrently or presently under construction;
- .3 the Bid complies with the Bidding Documents;
- .4 the Bidder has visited the site, become familiar with local conditions under which the Work is to be performed, and has correlated the Bidder's observations with the requirements of the Proposed Contract Documents;
- .5 the Bid is based upon the materials, equipment, and systems required by the Bidding Documents without exception; and
- .6 the Bidder has read and understands the provisions for liquidated damages, if any, set forth in the form of Agreement between the Owner and Contractor.

§ 2.2 The Bidder is licensed by the State Licensing Board for General Contractors and the amount Bid does not exceed the Bid Limit stipulated in the Bidder's License and by the City of Mobile.

§ 2.3 Each and every Contractor belonging to or comprising a part of any entity that is bidding as a joint venture or association involving two or more contractors is licensed by the State Licensing Board for General Contractors and that the amount Bid does not exceed the Bid limit stipulated in at least one of their licenses.

§ 2.4 Any non-resident Bidder is authorized by the Secretary of State of Alabama and is registered with Alabama Department of Revenue to transact business in Alabama.

§ 2.5 Joint Ventures or Associations of Contractors, whether the same are Bidders or Subcontractors of Bidders, will remain in existence until all insurance and warranty requirements for the Project have been fulfilled.

ARTICLE 3 BIDDING DOCUMENTS

§ 3.1 Distribution

§ 3.1.1 Bidders shall obtain complete Bidding Documents, as indicated below, from the issuing office designated in the advertisement or invitation to bid, for the deposit sum, if any, stated therein.

(Paragraphs deleted)

§ 3.1.2 Any required deposit shall be refunded to Bidders who submit a bona fide Bid and return the paper Bidding Documents in good condition within ten days after receipt of Bids. The cost to replace missing or damaged paper documents will be deducted from the deposit. A Bidder receiving a Contract award may retain the paper Bidding Documents, and the Bidder's deposit will be refunded.

§ 3.1.3 Bidding Documents will not be issued directly to Sub-bidders unless specifically offered in the advertisement or invitation to bid, or in supplementary instructions to bidders.

§ 3.1.4 Bidders shall use complete Bidding Documents in preparing Bids. Neither the Owner nor Architect assumes responsibility for errors or misinterpretations resulting from the use of incomplete Bidding Documents.

§ 3.1.5 The Bidding Documents will be available for the sole purpose of obtaining Bids on the Work. No license or grant of use is conferred by distribution of the Bidding Documents.

§ 3.2 Modification or Interpretation of Bidding Documents

§ 3.2.1 The Bidder shall carefully study the Bidding Documents, shall examine the site and local conditions, and shall notify the Architect of errors, inconsistencies, or ambiguities discovered and request clarification or interpretation pursuant to Section 3.2.2.

§ 3.2.2 Requests for clarification or interpretation of the Bidding Documents shall be submitted by the Bidder in writing and shall be received by the Architect at least five (5) calendar days prior to the date for receipt of Bids.

(Paragraphs deleted)

§ 3.2.3 Modifications and interpretations of the Bidding Documents shall be made by Addendum. Modifications and interpretations of the Bidding Documents made in any other manner shall not be binding, and Bidders shall not rely upon them.

§ 3.2.4 The Contract Drawings and Specifications are intended to cooperate and agree, but should conflicts or difference be found to exist between the requirements within either and clarification has not been obtained in accordance with the above procedure prior to Bidding, then the most costly and/or restrictive interpretation by the decision of the Architectural Engineering Department Director will be final.

§ 3.3 Substitutions

§ 3.3.1 The materials, products, and equipment described in the Bidding Documents establish a standard of required function, dimension, appearance, and quality to be met by any proposed substitution.

§ 3.3.2 Substitution Process

§ 3.3.2.1 Written requests for substitutions shall be received by the Architect at least seven (7) calendar days prior to the date for receipt of Bids. Requests shall be submitted in the same manner as that established for submitting clarifications and interpretations in Section 3.2.2.

§ 3.3.2.2 Bidders shall submit substitution requests on a Substitution Request Form if one is provided in the Bidding Documents.

§ 3.3.2.3 If a Substitution Request Form is not provided, requests shall include (1) the name of the material or equipment specified in the Bidding Documents; (2) the reason for the requested substitution; (3) a complete description of the proposed substitution including the name of the material or equipment proposed as the substitute, performance and test data, and relevant drawings; and (4) any other information necessary for an evaluation. The request shall include a statement setting forth changes in other materials, equipment, or other portions of the Work, including changes in the work of other contracts or the impact on any Project Certifications (such as LEED), that will result from incorporation of the proposed substitution.

§ 3.3.3 The burden of proof of the merit of the proposed substitution is upon the proposer. The Architect's decision of approval or disapproval of a proposed substitution shall be final.

§ 3.3.4 If the Architect approves a proposed substitution prior to receipt of Bids, such approval shall be set forth in an Addendum. Approvals made in any other manner shall not be binding, and Bidders shall not rely upon them.

§ 3.3.5 No substitutions will be considered after the Contract award unless specifically provided for in the Contract Documents.

§ 3.3.6 See Division One Section "Substitution Procedures", if included in Specification.

§ 3.4 Addenda

§ 3.4.1 Addenda will be transmitted to Bidders known by the issuing office to have received complete Bidding Documents.

(Paragraphs deleted)

§ 3.4.2 Addenda will be available where Bidding Documents are on file.

§ 3.4.3 Addenda will be issued no later than two (2) days prior to the date for receipt of Bids, except an Addendum withdrawing the request for Bids or one which includes postponement of the date for receipt of Bids.

§ 3.4.4 Prior to submitting a Bid, each Bidder shall ascertain that the Bidder has received all Addenda issued, and the Bidder shall acknowledge their receipt in the Bid.

ARTICLE 4 BIDDING PROCEDURES

§ 4.1 Preparation of Bids

§ 4.1.1 Bids shall be submitted on the forms included with or identified in the Bidding Documents. No bid will be considered unless made out and submitted on a copy of the Bid Form, Section 00400. Additional Bid Forms will be furnished to prospective Bidders upon request.

§ 4.1.2 All blanks on the bid form shall be legibly executed. Paper bid forms shall be executed in a non-erasable medium.

§ 4.1.3 Sums shall be expressed in both words and numbers, unless noted otherwise on the bid form. In case of discrepancy, the amount entered in words shall govern.

§ 4.1.4 Edits to entries made on paper bid forms must be initialed by the signer of the Bid.

§ 4.1.5 All requested Alternates shall be bid. If no change in the Base Bid is required, enter "No Change" or as required by the bid form.

Unit Prices: Supply requested Unit Prices where shown on the Bid Form, Such Unit Prices shall be used to adjust the Contract Amount where the quantities shown on the Drawings and/or Specifications do not reflect amounts required for

completion of the work. Where Completion of the Work requires quantities in excess of those shown on the drawings and specifications, unit prices shall be used to compute an extra payment to the Contractor. Where completion of work required quantities less than those on the Drawings and/or specifications, unit prices shall be used to compute a credit to the Owner.

Contingency Allowance: As shown on the Bid Form, Contractor shall add the amount of the contingency allowance to the Base Bid to derive the Total Bid. The contingency allowance shall cover cost of material, labor, overhead, profit and other expenses for complete installation of items of additional work as required for a complete functional project. The contingency allowance shall be used to fund unforeseen conditions not covered in the construction documents and shall be subject to the provisions of change orders. Upon the completion of work any unused portion of the contingency allowance shall be credited to the Owner by change order.

§ 4.1.6 Where two or more Bids for designated portions of the Work have been requested, the Bidder may, without forfeiture of the bid security, state the Bidder's refusal to accept award of less than the combination of Bids stipulated by the Bidder. The Bidder shall neither make additional stipulations on the bid form nor qualify the Bid in any other manner.

§ 4.1.7 Each copy of the Bid shall state the legal name and legal status of the Bidder. As part of the documentation submitted with the Bid, the Bidder shall provide evidence of its legal authority to perform the Work in the jurisdiction where the Project is located. Each copy of the Bid shall be signed by the person or persons legally authorized to bind the Bidder to a contract. A Bid by a corporation shall further name the state of incorporation and have the corporate seal affixed. A Bid submitted by an agent shall have a current power of attorney attached, certifying the agent's authority to bind the Bidder.

§ 4.1.8 A Bidder shall incur all costs associated with the preparation of its Bid.

§ 4.2 Bid Security

§ 4.2.1 Each Bid shall be accompanied by the following bid security if so required in the Bidding Documents:
(Insert the form and amount of bid security.)

The Bidder shall provide a Bid Security in the form of a cashier's check drawn on a bank registered to do business in the State of Alabama and which is a member of the Federal Deposit Insurance Corporation, or a Bid Bond. Bid Security is required for bids exceeding \$10,000.00. Bid Security shall be in the amount of 5% of the TOTAL BID, but in no event more than \$10,000.00.

§ 4.2.2 The Bidder pledges to enter into a Contract with the Owner on the terms stated in the Bid and shall, if required, furnish bonds covering the faithful performance of the Contract and payment of all obligations arising thereunder. Should the Bidder refuse to enter into such Contract or fail to furnish such bonds if required, the amount of the bid security shall be forfeited to the Owner as liquidated damages, not as a penalty.

§ 4.2.3 If a surety bond is required as bid security, it shall be written on AIA Document A310™, Bid Bond, unless otherwise provided in the Bidding Documents. The attorney-in-fact who executes the bond on behalf of the surety shall affix to the bond a certified and current copy of an acceptable power of attorney. The Bidder shall provide surety bonds from a company or companies lawfully authorized to issue surety bonds in the jurisdiction where the Project is located.

§ 4.2.4 The Owner will have the right to retain the bid security of Bidders to whom an award is being considered until (a) the Contract has been executed and bonds, if required, have been furnished; (b) the specified time has elapsed so that Bids may be withdrawn; or (c) all Bids have been rejected.

§ 4.2.5 Bonds must be issued by a Surety authorized to do business in the State of Alabama. A Performance Bond and a Labor and Material Payment Bond are required for projects exceeding \$10,000.00. If the project cost is \$50,000.00 or more, the Surety must have a minimum rating of A/Class VI as reported by the latest issue of Best's Key Rating Guide Property-Casualty published by Alfred M. Best Company, Inc.

§ 4.3 Submission of Bids

§ 4.3.1 A Bidder shall submit its Bid as indicated below:
(Indicate how, such as by website, host site/platform, paper copy, or other method Bidders shall submit their Bid.)

Submission of Bid shall be as stated in Section 00100, Invitation to Bid, Paragraph 9, titled "Bid Submittal".

(Paragraph deleted)

§ 4.3.3 Bids shall be submitted by the date and time and at the place indicated in the invitation to bid. Bids submitted after the date and time for receipt of Bids, or at an incorrect place, will not be accepted and will be returned unopened.

§ 4.3.4 The Bidder shall assume full responsibility for timely delivery at the location designated for receipt of Bids.

§ 4.3.5 A Bid submitted by any method other than as provided in this Section 4.3 will not be accepted.

§ 4.4 Modification or Withdrawal of Bid

§ 4.4.1 Prior to the date and time designated for receipt of Bids, a Bidder may submit a new Bid to replace a Bid previously submitted, or withdraw its Bid entirely, by notice to the party designated to receive the Bids. Such notice shall be received and duly recorded by the receiving party on or before the date and time set for receipt of Bids. The receiving party shall verify that replaced or withdrawn Bids are removed from the other submitted Bids and not considered. Notice of submission of a replacement Bid or withdrawal of a Bid shall be worded so as not to reveal the amount of the original Bid.

§ 4.4.2 Withdrawn Bids may be resubmitted up to the date and time designated for the receipt of Bids in the same format as that established in Section 4.3, provided they fully conform with these Instructions to Bidders. Bid security, if required, shall be in an amount sufficient for the Bid as resubmitted.

(Paragraphs deleted)

ARTICLE 5 CONSIDERATION OF BIDS

§ 5.1 Opening of Bids

If stipulated in an advertisement or invitation to bid, or when otherwise required by law, Bids properly identified and received within the specified time limits will be publicly opened and read aloud. A summary of the Bids may be made available to Bidders.

§ 5.2 Rejection of Bids

Unless otherwise prohibited by law, the Owner shall have the right to reject any or all Bids.

§ 5.3 Acceptance of Bid (Award)

§ 5.3.1 It is the intent of the Owner to award a Contract to the lowest responsive and responsible Bidder, provided the Bid has been submitted in accordance with the requirements of the Bidding Documents and does not exceed the funds available. Unless otherwise prohibited by law, the Owner shall have the right to waive informalities and irregularities in a Bid received and to accept the Bid which, in the Owner's judgment, is in the Owner's best interests.

§ 5.3.2 The Owner shall accept Alternates in the order listed on the Bid Form to determine the lowest responsive and responsible Bidder on the basis of the sum of the Base Bid and Alternates accepted.

ARTICLE 6 POST-BID INFORMATION

§ 6.1 Contractor's Qualification Statement

Bidders to whom award of a Contract is under consideration shall submit to the Architect, upon request and within the timeframe specified by the Architect, a properly executed AIA Document A305™, Contractor's Qualification Statement, unless such a Statement has been previously required and submitted for this Bid.

(Paragraphs deleted)

§ 6.3 Submittals

§ 6.3.1 After notification of selection for the award of the Contract, the Bidder shall, within three (3) calendar days or as stipulated in the Bidding Documents, submit in writing to the Owner through the Architect:

- .1 a designation of the Work to be performed with the Bidder's own forces;
- .2 names of the principal products and systems proposed for the Work and the manufacturers and suppliers of each; and

- .3 names of persons or entities (including those who are to furnish materials or equipment fabricated to a special design) proposed for the principal portions of the Work.
- .4 The name of the Project Superintendent and Project Manager together with the resume of qualifications of each;
- .5 Nonresident Contractor shall submit a letter from an attorney as required by Subparagraph 11.1.2 below and;
- .6 Engineering Firm or Testing Laboratory for testing as specified.

§ 6.3.2 The Bidder will be required to establish to the satisfaction of the Architect and Owner the reliability and responsibility of the persons or entities proposed to furnish and perform the Work described in the Bidding Documents.

§ 6.3.3 Prior to the execution of the Contract, the Architect will notify the Bidder if either the Owner or Architect, after due investigation, has reasonable objection to a person or entity proposed by the Bidder. If the Owner or Architect has reasonable objection to a proposed person or entity, the Bidder may, at the Bidder's option, withdraw the Bid or submit an acceptable substitute person or entity. The Bidder may also submit any required adjustment in the Base Bid or Alternate Bid to account for the difference in cost occasioned by such substitution. The Owner may accept the adjusted bid price or disqualify the Bidder. In the event of either withdrawal or disqualification, bid security will not be forfeited.

§ 6.3.4 Persons and entities proposed by the Bidder and to whom the Owner and Architect have made no reasonable objection must be used on the Work for which they were proposed and shall not be changed except with the written consent of the Owner and Architect.

§ 6.3.5 The Contractor shall, within ten (10) calendar days of receiving Contract Forms for signature, furnish to the Owner the following items, along with the signed contract, or the Bid Security will be forfeited automatically without further delay:

- .1 A Signed Construction Contract;
- .2 Performance Bond and Labor and Material Payment Bond (originals) on all Bids over \$10,000.00;
- .3 Certificate of Insurance and copy of Builder's Risk Policy (original), as identified in the specifications;
- .4 Schedule of Values; and
- .5 Federal Immigration Law Compliance: E-Verify enrollment documentation.

§ 6.3.6 The Bid Check or Bond of the three (3) lowest Bidders will not be returned until after the Construction Contract is executed.

ARTICLE 7 PERFORMANCE BOND AND PAYMENT BOND

§ 7.1 Bond Requirements

§ 7.1.1 If stipulated in the Bidding Documents, the Bidder shall furnish bonds covering the faithful performance of the Contract and payment of all obligations arising thereunder.

§ 7.1.2 If the furnishing of such bonds is stipulated in the Bidding Documents, the cost shall be included in the Bid. If the furnishing of such bonds is required after receipt of bids and before execution of the Contract, the cost of such bonds shall be added to the Bid in determining the Contract Sum.

§ 7.1.3 The Bidder shall provide surety bonds from a company or companies lawfully authorized to issue surety bonds in the jurisdiction where the Project is located.

§ 7.1.4 Unless otherwise indicated below, the Penal Sum of the Payment and Performance Bonds shall be the amount of the Contract Sum.

§ 7.1.4 A Surety authorized to do business in the State of Alabama shall issue Performance Bond and Labor and Material Payment Bond, as required by the Contract Documents. If the project cost is \$50,000.00 or more, the Surety must have a minimum rating of A/Class VI as reported by the latest issue of Best's Key Rating Guide Property-Casualty, published by Alfred M. Best Company, Inc.

§ 7.2 Time of Delivery and Form of Bonds

§ 7.2.1 The Bidder shall deliver the required bonds to the Owner not later than ten (10) calendar days from receiving the Construction Contract forms for signature.

§ 7.2.2 The bonds shall be written on City's Performance Bond and Labor and Material Payment Bond forms.

§ 7.2.3 The bonds shall be dated on or after the date of the Contract.

§ 7.2.4 The Bidder shall require the attorney-in-fact who executes the required bonds on behalf of the surety to affix to the bond a certified and current copy of the power of attorney.

ARTICLE 8 FORM OF AGREEMENT BETWEEN OWNER AND CONTRACTOR

Unless otherwise required in the Bidding Documents, the Agreement for the Work will be written on AIA Document A101, Standard Form of Agreement Between Owner and Contractor Where the Basis of Payment Is a Stipulated Sum.

§ 8.1.1 AIA Document A101, Standard Form of Agreement Between Owner and Contractor where the Basis of Payment is a stipulated sum will be edited electronically and include the standard signatures as required by the City of Mobile.

ARTICLE 9 NONDISCRIMINATION

§9.1.1 Contractor shall comply with all Federal, State and local laws concerning nondiscrimination, including but not limited to City of Mobile Ordinance No. 14-034 which requires, *inter alia*, that all contractors performing work for the City of Mobile not discriminate on the basis of race, creed, color, national origin or disability, require that all subcontractors they engage do the same, and make every reasonable effort to assure that fifteen percent of the work performed under contract be awarded to socially and economically disadvantaged individuals and business entities. Contractor shall provide a completed copy of the City of Mobile Subcontracting and Major Supplier Plan with the Bid Form, for bids of \$250,000.00 or greater.

ARTICLE 10 USE OF DOMESTIC PRODUCTS

§ 10.1.1 Section 39-3-1 Code of Alabama provides that the Contractor agrees, in the execution of this contract, to use material supplies and products manufactured, mined, processed or otherwise produced in the United States or its territories, if available at reasonable prices, and that breach of this agreement by the Contractor shall result in the assessment of liquidated damages in an amount not less than \$500 nor more than 20 percent of the gross amount of the contract price.

§ 10.1.2 Section 39-3-4, Code of Alabama provides that the Contractor for a municipal construction project, financed by the State of Alabama or any political subdivision thereof, is required to use steel produced within the United States. If the Contractor violates the requirement to use domestic steel, this contract will automatically be revoked and the contractor shall not be entitled to any set-off or recoupment for labor or materials used up to the time of revocation.

ARTICLE 11 PREFERENCE TO RESIDENT CONTRACTORS

§ 11.1.1 Except for contracts funded in whole or in part with funds received from a federal agency, preference shall be given to Alabama resident contractors, and a nonresident bidder domiciled in a state having laws granting preference to local contractors shall be awarded the contracts only on the same basis as a the nonresident bidder's state awards contracts to Alabama contractors bidding under similar circumstances. In the letting of public contracts in which any state, county or municipal funds are utilized, resident contractors in Alabama, be they corporations, individuals or partnerships, are to be granted preference over nonresidents in awarding of contracts in the same manner and to the same extent as provided by the laws of the state of domicile of the nonresident.

§ 11.1.2 A successful nonresident bidder shall include in his post bid submittals a written opinion of an attorney at law licensed to practice law in such nonresident bidders' state of domicile, as to the preferences, if any or none, granted by the law of that state to its own business entities whose principal places of business are in that state in the letting of any or all public contracts.

ARTICLE 12 PRE-BID REQUIREMENTS

§ 12.1 STATE OF ALABAMA CONTRACTORS LICENSE

§ 12.1.1 If the Project total bid amount is \$50,000 or more, a license issued by the State of Alabama Licensing Board for General Contractors is required prior to submitting a bid and the licensed classification and bid limits must cover the type

of work in this project. See Invitation to Bid, Section 6 "Bidder Qualifications".

§ 12.2 A NONRESIDENT BIDDER

§ 12.2.1 Every bidder shall be registered with the Department of Revenue and with the Alabama Secretary of the State prior to bidding. The Secretary of State's "Business Entity ID" registration number shall be included on the bid form.

ARTICLE 13 POST-BID REQUIREMENTS

§ 13.1 CITY CONTRACTOR'S LICENSE

13.1.1 A City of Mobile Contractors License is required and must be current before the Contractor signs the Contract. Contractor must qualify and post \$10,000.00 Surety Bond with the Land Use/Code Administration Department before a Contractors License will be issued by the Revenue Department. Information on the City Contractors License may be obtained by writing or calling:

Land Use/Code Administration
P. O. Box 1827
Mobile, Alabama 36633-1827
Phone: 251.208.7421

Revenue Department
P. O. Box 1827
Mobile, Alabama 36633-1827
251.208.7461

13.2 E-VERIFY DOCUMENTATION

§ 13.2.1 The Contractor agrees that it shall comply with all of the requirements of the State of Alabama Immigration Law (Act. No. 2011-535 as amended by Act. No. 2012-491, Alabama Code (1975) Section 31-13-1, et. Seq., See Section 31-13-9), and the provisions of said Law, including all penalties for violation thereof, are incorporated therein.

13.3 PUBLIC CONTRACTS WITH ENTITIES ENGAGING IN CERTAIN BOYCOTT ACTIVITIES

§ 13.3 The Contractor represents and agrees that it is not currently engaged in, nor will engage in, any boycott of a person or entity based in or doing business with a jurisdiction with which the State of Alabama can enjoy open trade.

(Table deleted)(Paragraphs deleted)(Paragraphs deleted)

SECTION 00300 - SUPPLEMENTAL INSTRUCTIONS TO BIDDERS

1. BIDDING DOCUMENTS:
 - A. Bidders may obtain complete sets of Bid Documents, Drawings and Specifications (Project Manual) from <http://www.cityofmobile.org/bids>.
 - B. Bidders shall use the complete set of documents in preparing their bid. The City of Mobile nor the Engineer and or Architect assumes no responsibility for errors or misinterpretations resulting from use of an incomplete set of documents.
2. INTERPRETATION OF BID DOCUMENTS:
 - A. Bidders shall carefully study the Bid Documents and compare portions of the Bidding Documents with each other, shall examine the site and local conditions and shall at once report to the City of Mobile any errors, inconsistencies or ambiguities discovered.
 - B. Bidders requiring clarification or interpretation of the Bid Documents shall make a written request to the Architect or to Architectural Engineering Department Project Manager by 3:00 PM at least six (6) calendar days prior to the date for receipt of Bids. E-mail requests are preferred and should be sent to Sandy McArthur at smcarthur@watermarkarch.com.
 - C. Interpretations, corrections, and changes to the Bidding Documents will be made by a formal, written Addendum. Interpretations, corrections, and changes to the Bidding Documents made in any other manner will not be binding, and Bidders shall not rely on them.
 - D. Any discrepancy not resolved prior to Bidding shall be bid by the Contractor to provide for the most costly and/or restrictive interpretation of the documents.
3. BIDDING PROCEDURES:
 - A. No Bid will be considered unless made out and submitted on a copy of the Bid Form as set forth herein.
 - B. All blanks on the Bid Form shall be legibly executed in a non-erasable medium.
 - C. Sums shall be expressed in both words and figures. In the case of a discrepancy, the amount written in words shall govern.
 - D. Interlineations, alterations, and erasures must be initialed by the signer of the Bid.
 - E. All requested Unit Prices, Alternates, and Allowances shall be bid as indicated on the Bid Form and in the Bid Documents.
 - F. Addenda shall be considered as a part of the Bid Documents and those issued prior to the opening of Bids shall be acknowledged on the Bid Form and any adjustment in cost shall be included in the Contract Sum.
4. BID SECURITY:
 - A. A Cashier's Check drawn on bank registered to do business in the State of Alabama, and which is a member of the Federal Deposit Insurance Corporation made payable to the City of Mobile, or a Bid Bond in the amount of 5% of the Bid Amount, but in no case more than \$10,000, must accompany the Bid. By submitting a Bid Security, the Bidder pledges to enter a Contract with the City of Mobile on the terms stated in the Bid, and will, if required, furnish bonds covering faithful performance of the Contract and required insurance certificate. Should the Bidder refuse to enter into such Contract or fail to furnish such

bonds, insurance, and all other documents required by the Bid Documents, the amount of the Bid security shall be forfeited to the Owner as liquidated damages, not as a penalty.

- B. Bid Bond shall be valid for a minimum of sixty (60) days from the date of Bid. The City of Mobile reserves the right to retain the security of all Bidders until the successful Bidder enters the Contract or until sixty (60) days after Bid opening, whichever is sooner.
 - C. Bonds must be issued by a Surety licensed to do business in the State of Alabama. If the project cost is more than \$50,000.00 the Surety must have a minimum rating of A/Class VI as reported by the latest issue of Best's Key Rating Guide Property-Casualty published by Alfred M. Best Company, Inc.
 - D. Power of Attorney is required for all Bonds.
 - E. The Surety company shall be required to execute AIA Document G-707, "Consent of Surety to Final Payment" prior to Final Payment of retainage being made to the Contractor.
5. EXAMINATION OF DOCUMENTS AND SITE WORK:
- A. Before submitting a Bid, Bidders should carefully examine the Bid Documents, visit the site of the Work, including attending the Pre-Bid Conference, fully inform themselves as to existing conditions and limitations, and include in the Bid a sum to cover the cost of all items included in the Contract and necessary to perform the Work. The submission of a Bid will be considered as conclusive evidence that the Bidder has made such examination.
6. SUBMISSION OF BIDS:
- A. Bid, Bid Security, Sales Tax Form C-3A, City of Mobile Subcontracting & Major Supplier Plan and other supporting data as specified shall be submitted in a sealed, opaque envelope, approximately 9"x12" or larger and shall be marked on the outside with the words, "SEALED BID FOR CRICHTON FIRE STATION – DRIVE REPAIR", along with the Architectural Engineering Department's project number (FD-072-21), the Bid Date, and the Contractor's name, address, and City of Mobile Business License number and, if bidding in amounts greater than \$50,000, the Contractor's State of Alabama General Contractor's License number and classification of the Bidder issued by the State of Alabama Licensing Board for General Contractors shall be written on the envelope.
 - B. Bids shall be deposited at the designated location prior to the time and date for receipt of Bids. Bids received after the time and date specified in the Invitation to Bid, or as modified by Addendum, will not be considered. Late Bids will be returned to the Bidder unopened.
 - C. The Bidder shall assume full responsibility for timely delivery at the location designated for receipt of Bids.
 - D. Oral, telephonic, facsimile, or other electronically transmitted bids will not be considered.
7. MODIFICATION OR WITHDRAWAL OF BIDS:
- A. A Bid may not be modified, withdrawn, or canceled by the Bidder for a period of sixty (60) days following the time and date designated for receipt of bids, and each Bidder so agrees in submitting a Bid.
8. CONSIDERATION AND AWARD OF BIDS:
- A. At the discretion of the City of Mobile, the properly identified Bids received on time will be publicly opened and will be read aloud.

- B. The City shall have the right to reject any and all Bids. A Bid not accompanied by a required Bid security or by other data required by the Bidding Documents, or a Bid, which is in any way incomplete or irregular, is subject to rejection.
 - C. It is the intent of the City to award a Contract to the lowest qualified Bidder, provided the Bid has been submitted in accordance with the requirements of the Bidding Documents and does not exceed the funds available. The City shall have the right to waive informalities and irregularities in a Bid received and to accept the Bid, which, in the City's judgment, is in the City's best interest.
 - D. The award shall be based on the lowest Total Bid for the Base Bid and Allowances, plus any Alternates and/or options that may be accepted, as listed on the Bid Form.
9. **PROOF OF COMPETENCY OF BIDDER:**
- A. Bidders may be required to furnish evidence satisfactory to the City of Mobile that they have sufficient means and experience in the types of work called for to assure the completion of the Contract in a satisfactory manner.
10. **SIGNING OF CONTRACT:**
- A. The Standard Form of Agreement Between Owner and Contractor, AIA Document A101-2007, amended and included herein, shall serve as the Agreement between the City of Mobile and the Contractor.
 - B. The Bidder to whom the Contract is awarded shall, within ten (10) calendar days of receiving the Contract Forms, properly execute and deliver to the Owner, the following items with the signed Agreement:
 - (1). Performance Bond and Labor and Material Payment Bond (originals).
 - (2). Certificate of Insurance (original) with endorsement to the City of Mobile.
 - (3). Evidence of enrollment in the E-Verify program.
 - (4). Vender Information Sheet and Form W-9 Request for Taxpayer Identification Number and Certification
 - (5). Other documentation as required by the Contract Documents.
 - C. Failure or refusal to sign the Agreement or to provide Bonds or Certificates of Insurance in a form satisfactory to the City of Mobile, E-Verify verification, or other required documentation, shall subject the Bidder to immediate forfeiture of Bid Security.
 - D. On all documents: City of Mobile Business License, the Alabama Secretary of State Business Identity, the Alabama Secretary of State Certificate of Authority (out of state contractors), E-verify documentation, and ACORD Insurance Form, the Contractor's name shall be EXACTLY the same.
11. **NONDISCRIMINATION:**
- A. Contractor shall comply with all Federal, State and local laws concerning nondiscrimination, including but not limited to City of Mobile Ordinance No. 14-034 which requires, inter alia, that all contractors performing work for the City of Mobile not discriminate on the basis of race, creed, color, national origin or disability, require that all subcontractors they engage do the same, and make every reasonable effort to assure that fifteen percent of the work performed under contract be awarded to socially and economically disadvantaged individuals and business entities.

12. **AMERICANS WITH DISABILITIES ACT (ADA):**
- A. Bidders shall comply with the provisions of the Americans with Disabilities Act (ADA) of 1990, which prohibits discrimination against individuals with disabilities.
13. **USE OF DOMESTIC PRODUCTS:**
- A. Section 39-3-1, Alabama Code, 1975, provides that the Contractor agree, in the execution of this Contract, to use materials, supplies and products manufactured, mined, processed or otherwise produced in the United States or its territories, if available at reasonable prices, and that breach of this Agreement by the Contractor shall result in the assessment of liquidated damages in an amount not less than \$500.00 nor more than twenty (20) percent of gross amount of the Contract Price.
14. **NON-RESIDENT (OUT OF STATE) CONTRACTORS:**
- A. Preference to Resident Contractors: Section 39-3-5, Code of Alabama, 1975, provides that a non-resident (out of State) bidder domiciled in a state which grants a preference to local Contractors is to be awarded a public contract on the same basis as the non-resident bidder's state awards contracts to Alabama bidders. Alabama bidders are given a preference to the same extent that a non-resident bidder receives a preference in his home state. A non-resident bidder must include with any written bid documents a written opinion of an attorney licensed to practice in the non-resident bidder's state declaring what preferences, if any, exists in the non-resident's state.
- B. Certificate of Authority: All non-resident (Out of State) bidders shall be registered with the Secretary of State and Alabama Department of Revenue prior to submitting a Bid. Provide the Secretary of State Business "entity ID Number" on the Bid Form in the space provided.
15. **ALABAMA IMMIGRATION ACT:**
- A. The State of Alabama Immigration Law (Act No. 2011-535 as amended by Act No. 2012-491), requires that Contractors not violate federal immigration law or knowingly employ, hire for employment, or continue to employ an unauthorized alien within the State of Alabama. In addition, Contractors are required to enroll in the federal E-Verify program and to submit verification of electronic enrollment to the City of Mobile at contract execution. A sample of the required E-Verify form is included in Section 00600 of the Specifications as an example, but the Contractor's enrollment shall be substantiated by submittal of a copy of the electronic pages generated from the Homeland Security web site. Submit verification withing ten (10) calendar days of receiving the Contract forms for signature.
16. **CITY OF MOBILE BUSINESS LICENSE:**
- A. A City of Mobile Business License is required and must be current at the time of award and throughout contract period.
17. **CITY OF MOBILE CONTRACTOR'S BUSINESS LICENSE:**
- A. A City of Mobile Contractor's Business License is required and must be current when contractor signs the contract and throughout contract period.
- B. Contractor must qualify and post a \$10,000 surety bond with the Land Use/Code Administration Department before a Contractor's Business License will be issued by the Revenue Department. Information on the City Contractor's License may be obtained by writing or calling:
- | | |
|------------------------------|--------------------|
| Land Use/Code Administration | Revenue Department |
| P.O. Box 1827 | P.O. Box 1827 |

Mobile, Alabama 36633-1827
Phone: 251-208-7421

Mobile, Alabama 36633-1827
Phone: 251-208-7461

18. CONSTRUCTION SCHEDULE AND ACCESS:

- A. The Project shall be Substantially Complete on March 20, 2022.
- B. The Apparent Low Bidder shall meet with the City of Mobile to discuss the scheduling of construction activities. Within five (5) days of this meeting, the Contractor will submit a proposed Project Schedule for City of Mobile review and approval. The Contractor is expected to investigate thoroughly the condition of all work areas prior to submission of this Project Schedule. Coordinate areas of Work and Scheduling with the Owner: facility will remain in service during the construction period. Additionally, the Owner will have the SPBB Manufacturer and their subcontractors performing maintenance work during this project.
- C. Additional construction days due to inclement weather conditions will be granted only upon formal request, and only if such days are appropriately documented and are in excess of the NOAA/National Weather Service average rainfall (for the previous 5 years) for the given month. A “rain day” is defined as more than a “trace” (0.10”) of rain falling within a given 24-hour period. The written claim must also demonstrate and document how the adverse weather conditions adversely impacted which trade(s) on the critical path and why an extension of the construction period is required.

19. SITE CONSIDERATIONS:

- A. It is the Contractor’s responsibility to carefully remove and store any items not permanently installed if these items would impede the construction process. Items shall be stored on-site in a City-approved location. The Contractor then shall be responsible for re-installing all such items at the completion of the work. It is recommended that the Contractor photograph, videotape or in some other manner document any items to be removed and their condition, prior to removal.
- B. The Contractor shall be responsible for leaving the work area and adjacent site clear of unnecessary equipment and debris, etc. at the end of each workday. All final cleaning is the responsibility of the Contractor and shall be executed prior to acceptance of the facility and site. The Contractor shall provide a dumpster during construction. The dumpster is to be removed from the site as soon as practical. Debris that cannot be contained within the dumpster shall be removed promptly and must not be allowed to create an unsightly condition or to interfere with the operation of the facility.
- C. The Contractor is responsible for the removal of the dumpster, any storage containers and any security fencing, temporary erosion control (BMP’s), etc. as soon as practical after their use by the Contractor or the work is complete.
- D. Noise and strong smells shall be isolated or kept to a minimum when adjacent portions of the site are occupied.
- E. Coordinate areas of Work and Scheduling with the Owner: facility will remain in service during the construction period. Additionally, the Owner will have the SPBB Manufacturer and their subcontractors performing maintenance work during this project.

20. SALES AND USE TAX EXEPTION:

- A. As per the State of Alabama ACT 2013-205, the Alabama Department of Revenue (ADOR) has been granted the authority to issue a “Certificate of Exemption from Sales and Use Tax for Governmental Entities” on construction projects. Therefore, this project shall qualify for

State of Alabama Sales and Use Tax Exemptions under the ACT. It is the responsibility of the Bidder to confirm the potential tax-exempt status of their bid with the ADOR and include any such savings in their bid, as well as accounting for it on their bid form attachment Sales Tax Form C-3A.

- B. The full text of ACT 2013-205 is available on the State of Alabama Building Commission website at www.bc.alabama.gov

21. SUBMISSION OF LIEN WAIVERS AND DBE COMPLIANCE, UTILIZATION REPORTS:

- A. The Contractor shall provide completed “City of Mobile DBE Compliance Utilization Reports” and lien waivers, including those from Subcontractors, at each monthly Application for Payment submitted to the City of Mobile.

22. NOTICE OF COMPLETION:

- A. For Contracts \$50,000 or greater:
- B. Contractor shall provide proof of publication of Advertisement of Completion for four consecutive weeks in a local newspaper, as required in the Title 39, Section 39-1-1, Subsection (f), of the Code of Alabama. This Advertisement shall not begin until the Project has been accepted by the City of Mobile.
- C. Notice of Completion advertisement shall read as follows:

STATE OF ALABAMA
COUNTY OF MOBILE
NOTICE OF COMPLETION

In accordance with Chapter 1, Title 39, Code of Alabama, 1975. NOTICE IS HEREBY given that (COMPANY NAME) has completed the contract for Crichton fire Station – Drive Repair, FD-072-21. All persons having any claims for labor, material or otherwise in connection with this project should immediately notify the Architectural Engineering Department, City of Mobile, P.O. Box 1827, Mobile, Alabama 36633-1827.

- D. Advertisement shall not begin until the Project has been accepted by the City of Mobile as Substantially Complete.

23. CONTRACTOR WARRANTY AND CERTIFICATION:

- A. Upon completion of the contract, the Contractor shall certify under oath that all bills have been paid in full.
- B. Contractor shall provide a three-year labor and Materials Warranty on company letterhead in addition to other warranties required by the Bid Documents.

24. LIQUIDATED DAMAGES:

- A. A time charge equal to Two Hundred Fifty Dollars (\$250.00) per calendar day will be made against the Contractor for the entire period that any part of the Work remains uncompleted, or any required closeout documents are not acceptably submitted, for more than thirty (30) calendar days after the time specified for the Substantial Completion for the Work, the amount of which shall be deducted by The City of Mobile, and shall be retained by The City of Mobile out of monies otherwise due the Contractor in the final payment, not as a penalty, but as liquidated damages sustained.

END OF SECTION

SECTION 00410 - BID FORM

Copies of the following Bid Form shall be used. Bids submitted on alternate forms may be rejected. Fill in all blank spaces with an appropriate entry. Bid Form must be signed by an officer of the company and notarized.

TO: CITY OF MOBILE
205 GOVERNMENT ST., P.O. BOX 1827, MOBILE, AL, 36633

RE: CRICHTON FIRE STATION – DRIVE REPAIR
PROJECT NO. FD-072-21
200 DAVENPORT AVE., MOBILE, AL 36607

In compliance with the Bid Documents and having carefully and thoroughly examined said documents for the subject Work prepared by the City of Mobile, Architectural Engineering Department and Consultant dated February 4, 2022; and Addendum Number(s) _____, dated _____, 2022 (CAUTION: before submitting any bid it is the Bidder's responsibility to check with the Architectural Engineering Department for all Addenda or special instructions that may impact the Bid) thereto, receipt of which is hereby acknowledged, the premises and all conditions affecting the Work prior to making this Proposal, the Undersigned Bidder,

COMPANY NAME: _____

ADDRESS: _____

PHONE: _____

ALABAMA GENERAL CONTRACTOR LICENSE NO.: _____

CITY OF MOBILE BUSINESS LICENSE NO.: _____

SECRETARY OF STATE OF ALABAMA ACCOUNT NO.: _____
(Note: Secretary of State Account Number shall be filled in only by non-resident bidders)

SECRETARY OF STATE OF ALABAMA BUSINESS IDENTITY NO.: _____

(Check one)

(A Corporation)

(A Partnership)

(An Individual Doing Business)

hereby proposes to furnish all labor, materials, tools, equipment, and supplies and to sustain all the expenses incurred in performing the Work on the above captioned Project in accordance with the terms of the Contract Documents, and all applicable laws and regulations for the sum listed below. The Work of the Contract shall be Substantially Complete ninety (100) calendar days from commencement of the work as established by a formal Notice To Proceed provided by the Owner.

BID:

Base Bid: _____ .00

Contingency Allowance: _____ \$5,000.00

Total Bid (Base Bid + Allowances): _____ .00

(Amount in Figures)

_____ and no/100 dollars

(Amount in Words)

(Note: Show amount in both words and figures. In case of discrepancy, the amount in words shall govern). Bids shall be provided in whole dollar amounts with no cents.

UNIT PRICES:

Unit Price No. 1: EXCAVATION AND BACKFILL _____ Per Cubic Yard

Unit Price No. 2: REMOVE AND REPLACE ASPHALT PAVING..... _____ Per Square Foot

BID SECURITY: The undersigned Bidder agrees that the attached Bid Security, as a Cashier's Check drawn on a bank registered to do business in the State of Alabama and which is a member of the Federal Deposit Insurance Corporation or a Bid Bond, made payable to the City of Mobile, in the amount of 5% of the bid amount, but in no event more than \$10,000, is the proper measure of liquidated damages which the City will sustain by the failure of the undersigned to execute the Contract. Said Bid Security shall become the property of the City of Mobile as liquidated damages as specified in the Contract Documents.

CONTINGENCY ALLOWANCE: This Allowance shall be used for unforeseen conditions; the need to perform the additional work and any associated increases in the Contract Amount shall be agreed upon by the City of Mobile and the Contractor prior to ordering of the materials or undertaking of the work.

AMERICANS WITH DISABILITIES ACT (ADA): The undersigned Bidder agrees to fully comply with all requirements of the Americans with Disabilities Act of 1990 and the Amendment Act.

NONDISCRIMINATION: Contractor shall comply with all Federal, State and local laws concerning nondiscrimination, including but not limited to City of Mobile Ordinance No. 14-034 which requires, inter alia, that all contractors performing work for the City of Mobile not discriminate on the basis of race, creed, color, national origin or disability, require that all subcontractors they engage do the same, and make every reasonable effort to assure that fifteen percent of the work performed under contract be awarded to socially and economically disadvantaged individuals and business entities.

SIGNATURE: If the undersigned Bidder is incorporated, the entire legal title of the company followed by "a corporation" should be used. If Bidder is an individual, then that individual's full legal name followed by doing business as (d/b/a) and name of firm, if any, should be used. If Bidder is a partnership, then full name of each partner should be listed followed by "d/b/a" and name of firm, if any.

Ensure that name and exact arrangement thereof is the same on all forms submitted with this Bid. If a word is abbreviated in the official company name, such as "Co.", then use that abbreviation. If not abbreviated in the official name, spell out.

Bidder agrees not to revoke or withdraw this Bid until sixty (60) calendar days following the time and date for receipt of bids. If notified in writing of the acceptance of this Bid within this time period, Bidder agrees to execute a Contract based on this Bid on the proscribed form within ten (10) Calendar days of said notification and to furnish Performance Bond and Labor and Materials and Payment Bond as specified.

COMPANY NAME: _____
(Printed or Typed)

BY: _____
(Signature of Company Officer)

COMPANY OFFICER: _____
(Printed or Typed)

TITLE _____ **DATE** _____, 2022
(Printed or Typed)

Sworn to and subscribed before me this _____ day of _____, 2022

Notary Public

- Attachments:
- 1. Bid Security, with Power of Attorney
 - 2. Secretary of State Authorization (Out of state bidders only)
 - 3. Sales Tax Form C-3A
 - 4. Supplier Diversity Subcontracting & Major Supplier Plan

END OF BID FORM



OFFICE OF SUPPLIER DIVERSITY
CITY OF MOBILE

Subcontracting and Major Supplier Plan

Contact Office of Supplier Diversity for questions on completing this form.
Via email: Archonique.kidd@cityofmobile.org
251.208.7967
205 Government Street, 5th Floor

Bidders and Proposers – Please complete and submit these forms as required by your City of Mobile Bid or Proposal Specification.

If you are submitting a proposal in response to a Request for Qualifications, Request for Proposal, or other solicitation (“Solicitations”) issued by the City of Mobile, the bid specification may require you to utilize disadvantaged business enterprise (“DBE”) subcontractors and suppliers. If DBE participation is required, you must complete and submit these forms with your proposal. If required, failure to submit this form will render your bid non-responsive. NOTE: To satisfy participation requirements for a federally funded project, you must utilize DBEs certified through the Alabama Unified Certification Program.

If DBE participation is required, and you fail to satisfy the participation requirement, you must show that you made a good faith effort to include such participation; you will be required to submit DBE Compliance Form 2 and include additional information if needed. When so required, failure to address adequately the good faith effort factors on Form 2 will render your bid or proposal non-responsive. The “good faith effort” factors on Form 2 are not intended to be a mandatory, exhaustive, or exclusive.

You are encouraged to work with the City of Mobile Supplier Diversity Manager when preparing this form. Please consult with the City Supplier Diversity Manager for a list of eligible DBEs. The “good faith effort” factors on **Form 2** are not intended to be mandatory, exhaustive, or exclusive; they are a tool to help you, and the City of Mobile, determine whether you made efforts which, by their scope, intensity, and appropriateness to the objective, would reasonably be expected to fulfill the participation requirement.

About “**DBEs**”: Disadvantaged business enterprise or DBE means a for-profit small business concern (1) That is at least 51 percent owned by one or more individuals who are both socially and economically disadvantaged or, in the case of a corporation, in which 51 percent of the stock is owned by one or more such individuals; and (2) whose management and daily business operations are controlled by one or more of the socially and economically disadvantaged individuals who own it.

About “**Good Faith**” **Effort**: Good faith efforts means efforts to achieve a DBE goal or other requirement of this part which, by their scope, intensity, and appropriateness to the objective, can reasonably be expected to fulfill the program requirement. The City of Mobile expects contractors holding large contracts to recruit and engage DBEs to be a part of their team.

Failure to submit this form, when so required by the bid or proposal specification, will render your bid non-responsive.



OFFICE OF SUPPLIER DIVERSITY
CITY OF MOBILE

Subcontracting and Major Supplier Plan

Contact Office of Supplier Diversity for questions on completing this form.
Via email: Archonique.kidd@cityofmobile.org
251.208.7967
205 Government Street, 5th Floor

FORM 1: Background and Plan

Section I. Information about your company

Company	
Address	
Telephone	
E-Mail	

RFP/RFQ Solicitation Number	
Project Description	
Is your company a DBE company?	Yes <input type="checkbox"/> No <input type="checkbox"/>
Work force demographics	Male _____ Female _____ Minority _____ Non-minority _____ SDVO _____
Total #of Employees	_____

Subcontractor/Major Supplier Plan submitted by:

Printed Name: _____

Signature: _____ Date: _____

Title: _____

The following employee will be designated as the **DBE Liaison** for all communication regarding DBE participation including documentation for DBE participation and maintenance of records of Good Faith Efforts for this contract award:

Name: _____ Title: _____

Email: _____ Phone: _____



**OFFICE OF SUPPLIER DIVERSITY
CITY OF MOBILE**

Subcontracting and Major Supplier Plan

Contact Office of Supplier Diversity for questions on completing this form.
Via email: Archinique.kidd@cityofmobile.org
251.208.7967
205 Government Street, 5th Floor

Section II. Subcontractors/Major Vendors Supplier Plan submitted by:
FORM 1: Background and Plan (Cont'd)

Please Print Company _____ Your Bid/Proposal Amount \$ _____ Date: _____
/ / _____ Description _____
Name of Bidder/Proposer: _____

I intend to use the following subcontractors: (Attach additional pages if necessary)

Subcontractor or Major Supplier	Phone	Scope of Work to be performed	\$\$ Value to be Performed	% Of Your Bid Amount	DBE?	Official Verification Only



OFFICE OF SUPPLIER DIVERSITY
CITY OF MOBILE
 Subcontracting and Major Supplier Plan

Form 2: Good Faith Effort Documentation

Name of Bidder: _____

Contact Person: _____ Phone _____ Email _____

Please complete this form if you are unable to identify DBE subcontractors or suppliers to reach 15% of the value of your bid.

YES <input type="checkbox"/>	NO <input type="checkbox"/>	Did you do these suggested areas for DBE recruitment and engagement
		PRE-BID MEETING(S): The bidder attended all pre-bid meetings scheduled by the City to inform DBEs of contracting and subcontracting opportunities.
		CMDBE/ALDOT DBE LIST(S): The bidder utilized the Office of Supplier Diversity's list or lists of certified through the Alabama Department of Transportation UCP DBE Listing
		SMALL CONTRACT(S): The bidder selected specific portions of the work to be performed by DBEs in order to increase the likelihood of meeting the DBE goals (including breaking down contracts into smaller units to facilitate DBE participation). Consider support services, including insurance, accounting, temporary labor, and transportation, landscaping, and janitorial as potential areas for DBE use.
		FOLLOW-UP: The bidder followed-up initial indications of interest by DBEs by contacting those DBEs to determine with certainty if they remained interested in bidding.
		GOOD FAITH NEGOTIATIONS: The bidder negotiated in good faith with interested DBEs and did not reject DBEs as unqualified without sound business reasons based on a thorough investigation of their capabilities. Bidders are not expected to engage unqualified subcontractors or subcontractors whose pricing, after negotiation, remains excessive or unreasonable. (Please document qualification deficiencies or unreasonable pricing if it prevented your engagement of specific DBE subcontractors.)
		ADVERTISEMENT: The bidder advertised in general circulation and/or trade association publications concerning subcontracting opportunities and allowed DBEs reasonable time to respond.
		INTERNET ADVERTISING: The bidder advertised DBE and/or subcontracting opportunities in the newspaper or other internet portals that are accessible to DBEs and/or potential subcontractors.



OFFICE OF SUPPLIER DIVERSITY
CITY OF MOBILE

Subcontracting and Major Supplier Plan

		INFORMATION: The bidder provided interested DBEs with adequate information about the plans, specifications and requirements of the subcontract.
		WRITTEN NOTICE(S): The bidder/proposer took the necessary steps to provide written notice in a manner reasonably calculated to inform DBEs of subcontracting opportunities and allowed sufficient time for them to participate effectively.
		COMMUNITY RESOURCES: The bidder/proposer used the services of available community organizations, small and/or disadvantaged business assistance offices and other organizations that provided assistance in the recruitment and placement of DBE firms.

CONTRACT RECORDS:

The bidder/proposer has maintained the following records for each DBE that has bid on the subcontracting opportunity:

1. Name, address, email address and telephone number
2. A description of information provided by the bidder/proposer or subcontractor; and
3. A statement of whether an agreement was reached, and if not, why not, including any reasons for concluding that the DBE was unqualified to perform the job.

Section 2(B)

_____ There are not ways to break out 15% of the value of this contract for subcontractors / suppliers. Provide further detail in Section 2(c) if the inability to break-out 15% of the value of the contract was the reason, or a reason, you could not meet the participation requirements.

_____ Could not find sufficient DBEs to provide subcontracting or supplier services.

_____ DBEs were available but did not have sufficient qualifications or experience to meet the needs of this contract. Please indicate additional efforts you have taken to recruit and engage DBEs. _____

**SECTION 00415 - ACCOUNTING OF SALES TAX FORM C-3A
(ATTACHMENT TO BID FORM SECTION 00410)**

TO: CITY OF MOBILE
205 GOVERNMENT ST., P.O. BOX 1827, MOBILE, AL, 36633

RE: CRICHTON FIRE STATION – DRIVE REPAIR
PROJECT NO. FD-72-21
200 DAVENPORT AVE., MOBILE, AL 36607

SALES TAX ACCOUNTING

Pursuant to Act 2013-205, Section 1(g) the Contractor accounts for the sales tax NOT included in the bid proposal form as follows:

TOTAL BID: \$ _____
(Estimated Sales Tax Amount)

Failure to provide an accounting of sales tax shall render the bid non-responsive. Other than determining responsiveness, sales tax accounting shall not affect the bid pricing nor be considered in the determination of the lowest responsible and responsive bidder.

Legal Name of Bidder: _____

Mailing Address _____

***By (Legal Signature)** _____

***Name (type or print)** _____

***Title** _____

Telephone Number _____

**SECTION 00500
STANDARD FORM OF AGREEMENT BETWEEN OWNER AND CONTRACTOR**

PART 1 GENERAL

- A. This section includes the STANDARD FORM OF AGREEMENT BETWEEN OWNER and CONTRACTOR, AIA Document A101, wherein the basis of payment is a Stipulated Sum; the document has been electronically modified to meet the Owner's requirements and shall be used for the Project.

AIA® Document A101® – 2017

Standard Form of Agreement Between Owner and Contractor where the basis of payment is a Stipulated Sum

AGREEMENT made as of the _____ day of _____ in the year _____
(In words, indicate day, month and year.)

BETWEEN the Owner:
(Name, legal status, address and other information)

City of Mobile
P. O. Box 1827
Mobile, Alabama 36633-1827

and the Contractor:
(Name, legal status, address and other information)

CRICHTON FIRE STATION - DRIVE REPAIR
200 Davenport Avenue
Mobile, Alabama 36607
FD-072-21

City of Mobile Business License Number:
Secretary of State Registration Number:

for the following Project:
(Name, location and detailed description)

The Architect:
(Name, legal status, address and other information)

Watermark Design Group, LLC
2970 Cottage Hill Road, Suite 200
Mobile, Alabama 36606
And
Architectural Engineering Department
P. O. Box 1827
Mobile, Alabama 36633-1827

The Owner and Contractor agree as follows.

ADDITIONS AND DELETIONS:

The author of this document has added information needed for its completion. The author may also have revised the text of the original AIA standard form. An *Additions and Deletions Report* that notes added information as well as revisions to the standard form text is available from the author and should be reviewed. A vertical line in the left margin of this document indicates where the author has added necessary information and where the author has added to or deleted from the original AIA text.

This document has important legal consequences. Consultation with an attorney is encouraged with respect to its completion or modification.

The parties should complete A101®–2017, Exhibit A, Insurance and Bonds, contemporaneously with this Agreement. AIA Document A201®–2017, General Conditions of the Contract for Construction, is adopted in this document by reference. Do not use with other general conditions unless this document is modified.

Init.

TABLE OF ARTICLES

- 1 THE CONTRACT DOCUMENTS
- 2 THE WORK OF THIS CONTRACT
- 3 DATE OF COMMENCEMENT AND SUBSTANTIAL COMPLETION
- 4 CONTRACT SUM
- 5 PAYMENTS
- 6 DISPUTE RESOLUTION
- 7 TERMINATION OR SUSPENSION
- 8 MISCELLANEOUS PROVISIONS
- 9 ENUMERATION OF CONTRACT DOCUMENTS, INSURANCE AND BONDS

ARTICLE 1 THE CONTRACT DOCUMENTS

The Contract Documents consist of this Agreement, Conditions of the Contract (General, Supplementary, and other Conditions), Drawings, Specifications, Addenda issued prior to execution of this Agreement, other documents listed in this Agreement, and Modifications issued after execution of this Agreement, all of which form the Contract, and are as fully a part of the Contract as if attached to this Agreement or repeated herein. The Contract represents the entire and integrated agreement between the parties hereto and supersedes prior negotiations, representations, or agreements, either written or oral. An enumeration of the Contract Documents, other than a Modification, appears in Article 9.

ARTICLE 2 THE WORK OF THIS CONTRACT

The Contractor shall fully execute the Work described in the Contract Documents, except as specifically indicated in the Contract Documents to be the responsibility of others (See attachment Exhibit A).

ARTICLE 3 DATE OF COMMENCEMENT AND SUBSTANTIAL COMPLETION

§ 3.1 The date of commencement of the Work shall be:

(Check one of the following boxes.)

(Paragraph deleted)

Established by a formal Notice To Proceed provided by the Owner.

(Paragraphs deleted)

§ 3.2 The Contract Time shall be measured from the date of commencement of the Work.

§ 3.3 Substantial Completion

§ 3.3.1 Subject to adjustments of the Contract Time as provided in the Contract Documents, the Contractor shall achieve Substantial Completion of the entire Work:

(Check one of the following boxes and complete the necessary information.)

90 days from the formal Notice To Proceed provided by the Owner.

(Paragraphs deleted)

(Table deleted)

§ 3.3.3 If the Contractor fails to achieve Substantial Completion as provided in this Section 3.3, liquidated damages, if any, shall be assessed as set forth in Section 4.5.

ARTICLE 4 CONTRACT SUM

§ 4.1 The Owner shall pay the Contractor the Contract Sum in current funds for the Contractor's performance of the Contract. The Contract Sum shall be ___ and 00/100 Dollars (\$ ___.00), subject to additions and deductions as

Init.

provided in the Contract Documents.

Base Bid: \$
Contingency Allowance: \$ 5,000.00
Total Contract Sum: \$

§ 4.2 Alternates

§ 4.2.1 Alternates, if any, included in the Contract Sum:

Item	Price
------	-------

(Table deleted)

(Paragraphs deleted)

§ 4.3 Allowances, if any, included in the Contract Sum:

(Identify each allowance.)

Contingency Allowance: \$ 5,000.00

Contingency Allowances: Five Thousand and 00/100 Dollars (\$5,000.00).

- A. Contingency Allowance shall cover cost of material, labor, overhead, profit and other expenses for complete installation of items of additional work as required for a complete, functional project.
- B. Contingency Allowance shall be used for unforeseen conditions not covered in the construction documents.
- C. All extra work under this section must be authorized by the Owner, in writing, prior to materials or undertaking work.
- D. Upon completion of the Work, the unused portion of the Allowance shall be credited back to the Owner in the form of a Change Order.
- E. Allowances are subject to the same provision of AIA 201 Article 7.3.7.

§ 4.4 Unit prices, if any:

(Identify the item and state the unit price and quantity limitations, if any, to which the unit price will be applicable.)

Item	Units and Limitations	Price per Unit (\$0.00)
Unit Price No. 1: EXCAVATION AND BACKFILL	Per Cubic Yard	
Unit Price No. 2: REMOVE AND REPLACE ASPHALT PAVING	Per Square Foot	

§ 4.5 Liquidated damages:

(Insert terms and conditions for liquidated damages, if any.)

A time charge equal to Two Hundred Fifty and 00/100 Dollars (\$250.00) per calendar day will be made against the Contractor for the entire period that any part of the Work remains uncompleted or any required closeouts documents are not acceptably submitted for more than thirty (30) days after the date specified for the substantial Completion of the Work, the amount of which shall be deducted by the owner, and shall be retained by the Owner out of monies otherwise due the Contractor in the final payment, not as a penalty, but as liquidated damages sustained.

(Paragraphs deleted)

Init.

ARTICLE 5 PAYMENTS

§ 5.1 Progress Payments

§ 5.1.1 Based upon Applications for Payment submitted to the Architect by the Contractor and Certificates for Payment issued by the Architect, the Owner shall make progress payments on account of the Contract Sum to the Contractor as provided below and elsewhere in the Contract Documents.

§ 5.1.2 The period covered by each Application for Payment shall be one calendar month ending on the 25th of the month.

§ 5.1.3 Provided that an Application for Payment in acceptable format is received by the Architect not later than the first 1st day of a month, the Owner shall make payment of the amount certified to the Contractor not later than the tenth 10th day of the following month. If an Application for Payment in acceptable format is received by the Architect after the application date fixed above, payment of the amount certified shall be made by the Owner not later than forty (40) days after the Architect receives the Application for Payment.
(Federal, state or local laws may require payment within a certain period of time.)

§ 5.1.4 Each Application for Payment shall be based on the most recent schedule of values submitted by the Contractor in accordance with the Contract Documents. The schedule of values shall allocate the entire Contract Sum among the various portions of the Work. The schedule of values shall be prepared in such form, and supported by such data to substantiate its accuracy, as the Architect may require. This accepted schedule of values shall be used as a basis for reviewing the Contractor's Applications for Payment.

§ 5.1.5 Applications for Payment shall show the percentage of completion of each portion of the Work as of the end of the period covered by the Application for Payment.

§ 5.1.6 In accordance with AIA Document A201, General Conditions of the Contract for Construction (including Owner's then-current modifications), and subject to other provisions of the Contract Documents, the amount of each progress payment shall be computed as follows:

§ 5.1.6.1 The amount of each progress payment shall first include:

- .1 That portion of the Contract Sum properly allocable to completed Work;
- .2 That portion of the Contract Sum properly allocable to materials and equipment delivered and suitably stored at the site for subsequent incorporation in the completed construction, or, if approved in advance by the Owner, suitably stored off the site at a location agreed upon in writing and insured as specified;
- .3 Completed work shall be determined by multiplying the percentage completion of each portion of the Work by the share of the Contract Sum allocated to that portion of the Work in the schedule of values.

§ 5.1.6.2 The amount of each progress payment shall then be reduced by:

- .1 The aggregate of any amounts previously paid by the Owner;
- .2 The amount, if any, for Work that remains uncorrected and for which the Architect has previously withheld a Certificate for Payment as provided in Article 9 of AIA Document A201-2017;
- .3 Any amount for which the Contractor does not intend to pay a Subcontractor or material supplier, unless the Work has been performed by others the Contractor intends to pay;
- .4 For Work performed or defects discovered since the last payment application, any amount for which the Architect may withhold payment, or nullify a Certificate of Payment in whole or in part, as provided in Article 9 of AIA Document A201-2017; and
- .5 Retainage withheld pursuant to Section 5.1.7.

§ 5.1.6.3 Any Progress Payment shall include partial release of liens for material and labor for previous application for payment amount approved and paid. The DBE Utilization Report shall be included with the pay application.

§ 5.1.7 Retainage

§ 5.1.7.1 For each progress payment made prior to Substantial Completion of the Work, the Owner may withhold the following amount, as retainage, from the payment otherwise due:

Init.

(Insert a percentage or amount to be withheld as retainage from each Application for Payment. The amount of retainage may be limited by governing law.)

Five percent (5%) of the first fifty percent (50%) of the completed work and after fifty percent (50%) completion has been accomplished, no further retainage shall be held from the original Contract Sum. Increases in the contract sum by Change Order shall also be subject to retainage.

§ 5.1.7.1.1 The following items are not subject to retainage:

(Insert any items not subject to the withholding of retainage, such as general conditions, insurance, etc.)

N/A

(Paragraphs deleted)

§ 5.1.7.3 Except as set forth in this Section 5.1.7.3, upon Substantial Completion of the Work, the Contractor may submit an Application for Payment that includes the retainage withheld from prior Applications for Payment pursuant to this Section 5.1.7. The Application for Payment submitted at Substantial Completion shall not include retainage as follows:

(Insert any other conditions for release of retainage upon Substantial Completion.)

The net amount of the Retainage shall be equal to two and one half percent (2.5%) of total Contract Sum, as increased or decreased by Change Order.

§ 5.1.8 If final completion of the Work is materially delayed through no fault of the Contractor, the Owner shall pay the Contractor any additional amounts in accordance with Article 9 of AIA Document A201.

§ 5.1.9 Except with the Owner's prior approval, the Contractor shall not make advance payments to suppliers for materials or equipment which have not been delivered and stored at the site.

§ 5.2 Final Payment

§ 5.2.1 Final monthly progress payment, constituting the entire unpaid balance of the Contract Sum, less retainage, shall be made by the Owner to the Contractor when

- .1 the Contractor has fully performed the Contract except for the Contractor's responsibility to correct Work as provided in Article 12 of AIA Document A201 (including Owner's then-current modifications which may be obtained from the Owner or, alternatively, a copy of which is incorporated in the Project Manual and incorporated by reference herein as a part thereof), and to satisfy other requirements, if any, which extend beyond final payment; and
- .2 a Certificate of Substantial Completion has been issued by the Architect/Owner and the project accepted.

§ 5.2.2 The Owner's final payment to the Contractor of retainage shall be made as follows:

The final two and one half percent (2.5%) of the total Contract Sum retained will not be paid until proof of publication is submitted and all written claims paid in full. Contractor to submit the following:

- Contractor's Affidavit of Payment of Debts and Claims (AIA form G706, included in contract documents) with
 - a.) Contractor's Release or Waiver of Liens
 - b.) Releases or Waivers of Liens from Subcontractors and Material and Equipment Suppliers;
- Contractor's Affidavit of Release of Liens (AIA form G706A, included in contract documents);
- Consent of Surety, if any, to final payment (AIA form G707, included in contract documents);
- Any additional close out requirements per the contract documents; and
- Notarized Affidavit of Notice of Completion advertisement from publisher.

Contractor shall provide proof of publication of Notice of Completion in a local newspaper once per week for four (4) consecutive weeks, as required in the Title 39, Section 39-1-1, Subsection (f), of the Code of Alabama quoted below. "The Contractor shall, immediately after the completion of the contract, give notice of Completion by an

Init.

AIA Document A101® – 2017. Copyright © 1915, 1918, 1925, 1937, 1951, 1958, 1961, 1963, 1967, 1974, 1977, 1987, 1991, 1997, 2007 and 2017 by The American Institute of Architects. All rights reserved. The "American Institute of Architects," "AIA," the AIA Logo, "A101," and "AIA Contract Documents" are registered trademarks and may not be used without permission. This document was produced by AIA software at 13:34:45 ET on 10/20/2021 under Order No.3480167681 which expires on 08/28/2022, is not for resale, is licensed for one-time use only, and may only be used in accordance with the AIA Contract Documents' Terms of Service. To report copyright violations, e-mail copyright@aia.org.

User Notes:

(1298679914)

advertisement in a newspaper of general circulation published within the city or county in which the work has been done, for a period of four (4) consecutive weeks. A final settlement shall not be made upon the contract until the expiration of thirty (30) days after the completion of the notice. Proof of publication of the notice shall be made by the contractor to the authority by whom the contract was made by affidavit of the publisher and a printed copy of the notice published. If no newspaper is published in the county in which the work is done, the notice may be given by the contract." (Acts 1927, No. 39, 9.37; Acts 1935, No. 39, 9. 70; Code 1940, T. 50, Section 16; Acts 1983, No. 83-737, 9.1203; Acts 1989, No. 89-650m 9. 1284, Section 1; Acts 1994, No. 94-207, p, 270, Section 1; Acts 1997, No. 97-225, p. 348, Section 1.)

The Notice of Completion shall read as follows:

STATE OF ALABAMA
COUNTY OF MOBILE
NOTICE OF COMPLETION

In accordance with Chapter I, Title 39, Code of Alabama, 1975, NOTICE IS HEREBY given that () has completed the contract for CRICHTON FIRE STATION - DRIVE REPAIR, FD-072-21, 200 Davenport Avenue Mobile, Alabama 36607. All persons having any claims for labor, material or otherwise in connection with this project should immediately notify the Architectural Engineering Department, City of Mobile, P. O. Box 1827, Mobile, Alabama 36633-1827.

Publication of the Notice of Completion shall not begin until the Project has been accepted as Substantially Complete by the City of Mobile.

(Paragraphs deleted)

ARTICLE 6 DISPUTE RESOLUTION

§ 6.1 Initial Decision Maker

The Engineer will serve as the Initial Decision Maker pursuant to Article 15 of AIA Document A201, unless the parties appoint below another individual, not a party to this Agreement, to serve as the Initial Decision Maker.

(If the parties mutually agree, insert the name, address and other contact information of the Initial Decision Maker, if other than the Architect.)

N/A

§ 6.2 Binding Dispute Resolution

For any Claim, the method of binding dispute resolution shall be as follows:

(Check the appropriate box.)

(Paragraph deleted)

[X] Litigation in a court of competent jurisdiction

§ 6.3 Governing Law and Venue

(Paragraph deleted)

This Agreement shall be governed by the laws of the State of Alabama, and the appropriate venue of any actions arising out of this Agreement shall be a court of proper jurisdiction in Mobile, Alabama.

ARTICLE 7 TERMINATION OR SUSPENSION

§ 7.1 The Contract may be terminated by the Owner or the Contractor as provided in Article 14 of AIA Document A201, General Conditions of the Contract for Construction, including Owner's then-current modifications, a copy of which is incorporated in the contract documents and incorporated by reference herein as a part thereof..

(Paragraphs deleted)

Init.

§ 7.2 The Work may be suspended by the Owner as provided in Article 14 of AIA Document A201, General Conditions of the Contract for Construction, including Owner's then-current modifications, a copy of which is incorporated in the contract documents and incorporated by reference herein as a part thereof.

ARTICLE 8 MISCELLANEOUS PROVISIONS

§ 8.1 Where reference is made in this Agreement to a provision of AIA Document A201 or another Contract Document, the reference refers to that provision as amended or supplemented by other provisions of the Contract Documents. A copy of such amended, revised or supplemental provision is incorporated in the contract documents and hereby incorporated by reference herein as a part thereof.

§ 8.2 The Owner's representative:
(Name, address, email address, and other information)

Director, Real Estate Asset Management
P. O. Box 1827
Mobile, Alabama 36633-1827

§ 8.3 The Contractor's representative:
(Name, address, email address, and other information)

§ 8.4 Neither the Owner's nor the Contractor's representative shall be changed without ten days' prior notice to the other party.

§ 8.5 Insurance and Bonds

§ 8.5.1 The Owner and the Contractor shall purchase and maintain insurance as set forth below:

The Contractor shall purchase and maintain from a company or companies lawfully authorized to do business in the jurisdiction in which the Project is located such insurance as will protect the Contractor from claims set forth below which may arise out of or result from the Contractor's operations be by the Contractor or by a Subcontractor or by anyone directly or indirectly employed by any of them, or by anyone for whose acts any of them may be liable:

- .1 Claims under workers' compensation, disability benefit and other similar employee benefit acts that are applicable to the Work to be performed;
- .2 Claims for damages because of bodily injury, occupational sickness or disease, or death of the Contractor's employees;
- .3 Claims for damages because of bodily injury, sickness or disease, or death of any person other than the Contractor's employees;
- .4 Claims for damages insured by usual personal injury liability coverage;
- .5 Claims for damages, because of injury to or destruction of tangible property, including loss of use resulting therefrom;
- .6 Claims for damages because of bodily injury, death of a person or property damage arising out of ownership, maintenance or use of a motor vehicle;
- .7 Claims for bodily injury or property damage arising out of completed operations; and
- .8 Claims involving contractual liability insurance applicable to the Contractor's obligations under Section 3.18 of the General Conditions of the Contract for Construction.

The Contractor shall take out and maintain during the life of the Contract no less than the following amounts of insurance with the City of Mobile named as an additional insured. Contractor shall submit a Certificate of Insurance. Insurance companies listed as the "Companies Affording Coverage" shall be authorized by the Secretary of the State of Alabama. Insurance produced out of the State of Alabama must be signed or counter signed by a licensed Agent of Alabama, with the Agent's name, address and telephone number typed or printed on the face of the Certificate of Insurance.

- .1 Workmen's Compensation Insurance: - Statutory-amount and coverage as required by all applicable laws, rules or regulations of the State of Alabama and the United States of America, including the U. S. Longshore and Harbor Workers Act and the Jones Act, if applicable.

Init.

- .2 Employee's Liability Insurance shall be provided for limits of liability not less than:
- | | | |
|----|---------------------------|---------------------------|
| A. | Bodily Injury by Accident | \$1,000,000 each accident |
| B. | Bodily Injury by Disease | \$1,000,000 each employee |
| C. | Bodily Injury by Disease | \$1,000,000 each policy |
- .3 United States Longshoreman's Harbor Worker's Act.
- .4 Jones Act Coverage (if applicable) placed either in the Workers Compensation or through the Marine General Liability.
- .5 The Contractor shall provide Broad Form (commonly termed Comprehensive) General Liability Insurance (including premises-product-completed operations, independent contractors, and blanket contractual liability), specifically covering the obligations assumed by the Contractor for limits of liability not less than:
- | | | |
|----|-----------------------------------|-----------------------------------|
| A. | Bodily Injury | \$1,000,000 each person |
| | | \$1,000,000 each occurrence |
| B. | Property Damage | \$1,000,000 each occurrence; or |
| C. | Bodily Injury and Property Damage | \$1,000,000 combined single limit |
- .6 Such comprehensive policy shall include the following:
- | | |
|----|---|
| A. | All liability of the Contractor, for the Contractor's Direct Operations. |
| B. | Subcontractor's Operations. |
| C. | Completed Operations Cover, thereby meaning any loss which shall occur after the contract has been completed, but which can be traced back to the Contract. |
| D. | General Aggregate Limit of \$2,000,000 shall apply on a "Per Project" Basis. |
| E. | Contractual Liability, meaning thereby; any risk assumed by the Contractor under Hold Harmless Agreements or any other assumption of liability, but specifically items 11.1.1.8.3G herein below |
| F. | Broad Form Property damage Coverage, including Completed Operations. |
| G. | Personal Injury Liability, with employee's exclusions removed. |
| H. | Explosion and Collapse Hazard:
Included or X Not Applicable. |
| I. | Underground Hazard:
Included or X Not Applicable. |
| J. | Marine General Liability shall include Premises and Operations, Personal and Advertising Injury, Products and Completed Operations, Protection and Indemnity including vessel and crew (if applicable). |
| K. | Deletion of watercraft exclusion with respect to non-owned vessels and contractual Liability for watercraft exposure not covered by Protection and Indemnity policy. |
| L. | The Marine General Liability policy must include an endorsement to cover "Sudden And Accidental Pollution." |
- .7 The Contractor shall carry for himself and shall require that all Subcontractors and all Owners of Automobiles or trucks rented or hired on the contract carry, until the Contracts is completed, Comprehensive Automobile Liability Coverage for Bodily Injury and property. Damage for any

auto in amounts not less than the minimum amounts as indicated. The Contractor and Subcontractor shall also carry for themselves insurance for all non-owned and hired automobile at the limits of liability as indicated below:

- A. Bodily Injury \$1,000,000 each person
\$1,000,000 each occurrence
 - B. Property damage \$1,000,000 each occurrence; or,
 - C. Bodily Injury and Property damage \$1,000,000 combined single limit
- .8 Umbrella/Excess Liability: \$2,000,000 combined single limit each occurrence for bodily injury and/or property damage
- .9 Builder's Risk Coverage (Property Insurance): The Contractor shall carry for the Owner, himself, and all Subcontractors a Builder's Risk Policy to cover the full amount of the Contract during construction, fabrication or erection of any equipment.
- A. The Contractor shall purchase and maintain, in a company or companies lawfully authorized to do business in the jurisdiction in which the Project is located, property insurance written on a builder's risk "all-risk" or equivalent policy form in the amount of the initial Contract Sum, plus value of subsequent Contract Modifications and cost of materials supplied or installed by others, comprising total value for the entire Project at the site on a replacement cost basis. Such property insurance shall be maintained, unless otherwise provided in the Contract Documents or otherwise agreed in writing by all persons and entities who are beneficiaries of such insurance, until final payment has been made as provided in Section 9.10 or until no person or entity other than the Owner has an insurable interest in the property, whichever is later. This insurance shall include interests of the Owner, the Contractor, Subcontractors, Sub-subcontractors, and the Design Professionals in the Project.
 - B. Property insurance shall be on an "all-risk" or equivalent policy form and shall include, without limitation, insurance against the perils of fire (with extended coverage) and physical loss or damage including, without duplication of coverage, theft, vandalism, malicious mischief, collapse, windstorm, falsework, testing and startup, temporary buildings and debris removal including demolition occasioned by enforcement of any applicable legal requirements, and shall cover reasonable compensation for Architect's and Contractor's services and expenses required as a result of such insured loss.
 - C. If the property insurance requires deductibles, the Contractor shall pay costs not covered because of such deductibles. Deductibles shall be limited to a maximum of \$2,500.00 unless the loss is caused by windstorm; then deductible shall be a maximum of three percent (3%) of insured value.
 - D. This property insurance shall cover the full value of equipment, material, and other portions of the Work stored off the site, and also portions of the Work in transit. There shall be no limits on the value of loss per occurrence.
 - E. A named storm endorsement is required. The deductible shall be a maximum of three percent (3%) of insured value.
- .10 A Surety authorized to do business in the State of Alabama shall furnish the required Insurance.
- .11 The standard ACORD™ format shall be provided. The ACORD™ Certificate must be signed or countersigned by a Licensed Resident Agent of the State of Alabama and the agent's name, address and telephone number must appear on the face of the certificate.

- .12 The Surety must have a minimum rating of A/Class VI as reported in the latest issue of Best's Key Rating Guide Property-Casualty, published by Alfred M. Best Company, Inc. if the bid price exceeds \$50,000.00.
- .13 "In Rem" endorsement.

The insurance shall be written for not less than limits of liability specified in the Contract Documents or required by law, whichever coverage is greater. Coverages, whether written on an occurrence or claims-made basis, shall be maintained without interruption from the date of commencement of the Work until the date of final payment and termination of any coverage required to be maintained after final payment, and, with respect to the Contractor's completed operations coverage, until the expiration of the period for correction of Work or for such other period for maintenance of completed operations coverage as specified in the Contract Documents.

Certificates of insurance acceptable to the Owner shall be filed with the Owner within ten (10) calendar days from date of issuance of contract forms for execution. Contractor shall deliver to the City of Mobile, certificates of insurance certifying the existence and limits of the insurance coverages along with separate policy endorsements. Contractor shall also be responsible for delivering policy renewal certificates to the City of Mobile, and thereafter upon renewal or replacement of each required policy of insurance. These certificates and the insurance policies shall contain a provision that coverages afforded under the policies will not be cancelled subject to non-renewal nor material change, or allowed to expire without at least thirty (30) days' (except ten (10) days from non-payment) prior written notice has been given to the Owner. An additional certificate evidencing continuation of liability coverage, including coverage for completed operations, shall be submitted with the final Application for Payment and thereafter upon renewal or replacement of such coverage until the expiration of the time. Information concerning reduction of coverage on account of revised limits or claims paid under the General Aggregate, or both, shall be furnished by the Contractor with reasonable promptness.

All policies of insurance, except worker's compensation, shall be endorsed to provide that all such insurances are primary and non-contributing with any other insurance maintained by the City of Mobile and endorsed to waive rights of subrogation in favor of the City of Mobile.

The Contractor shall cause the commercial liability coverage required by the Contract Documents to include (1) the Owner, the Architect and the Architect's Consultants as additional insureds for claims caused in whole or in part by the Contractor's negligent acts or omissions during the Contractor's operations; and (2) the Owner as an additional insured for claims caused in whole or in part by the Contractor's negligent acts or omissions during the Contractor's completed operations.

§ 8.5.2 The Contractor shall provide bonds as set forth below:

Contractor shall furnish bonds covering faithful performance of the Contract and payment of obligations arising thereunder.

Upon the request of any person or entity appearing to be a potential beneficiary of bonds covering payment of obligations arising under the Contract, the Contractor shall promptly furnish a copy of the bonds or shall authorize a copy to be furnished.

The Labor and Material Payment Bond and the Performance Bond shall each be for one hundred percent (100%) of the Contract Sum.

1. Bond shall be submitted with the executed agreement on provided form(s).
2. Power of Attorney is required for both bonds.
3. A Surety authorized to do business in the State of Alabama shall furnish both bonds.
4. A Surety licensed to do business in the State of Alabama must execute the bonds.
5. The Surety must have a minimum rating of A/Class VI as reported in the latest issue of Best's Key

Rating Guide Property-Casualty, published by Alfred M. Best Company, Inc., if the bid price exceeds \$50,000.00.

6. The Surety company shall be required to execute AIA Document G-707, "Consent of Surety to Final Payment" prior to Final Payment being made to the Contractor.

§ 8.6

(Paragraphs deleted)

Indemnification:

Contractor shall indemnify, defend and hold harmless City and its officers, elected officials, agents, representatives, and employees in respect of any and all claims, injuries, losses, diminution in value, damages, liabilities, whether or not currently due, and related expenses (including without limitation, settlement costs and any legal or other expenses for investigating or defending any actions or threatened actions) arising from or in connection with Contractor's performance under this agreement, including but not limited to, environmental laws, regulations, orders and decrees of whatever character or nature and damage or injury to persons or property.

§ 8.7 Other Provisions:

Contractor shall provide a minimum one (1) year warranty from the date of substantial completion of all Labor and Materials for the Work covered by this contract, unless otherwise specified. Labor and Material warranties required by other sections of the construction document shall not conflict with this provision. The most stringent warranty provision shall apply.

§ 8.8 Force Majeure:

In the event that either party hereto shall be delayed or hindered in or prevented from the performance of any act required hereunder by reason of strikes, lockouts, labor troubles, inability to procure materials, failure of power, restrictive governmental laws or regulations, riots, insurrection, war, Act of God, or other reason of a like nature not the fault of the party delayed in performing work or doing acts required under the terms of this Agreement, then performance of such act shall be excused for the period of the delay and the period for the performance of any such act shall be extended for a period equivalent to the period of such delay.

§ 8.9 Health Practices:

CDC/NIH Covid-19 Guidelines are in effect throughout contract duration. The Contractor shall adhere to current guidelines as directed by the City. All Contractor's personnel, Sub-Contractors, Material Suppliers and others shall wear a face mask/face covering at all times while in a City of Mobile building, adhere to current social distancing guidelines, and note that temperature checks may be conducted.

ARTICLE 9 ENUMERATION OF CONTRACT DOCUMENTS

§ 9.1 This Agreement is comprised of the following documents:

- .1 AIA Document A101™-2017, Standard Form of Agreement Between Owner and Contractor
- .2 AIA Document A201, General Conditions of the Contract for

(Paragraphs deleted)

Construction, including Owner's then-current modifications, a copy of which is incorporated in the contract documents and incorporated by reference herein as a part thereof.

(Paragraph deleted)

- .3 Drawings

Conformed Issued for Construction Drawing Index to be included as attachment in Executed Contract

- .4 Specifications

Conformed Issued for Construction Project Manual Table of Contents to be included as attachment in Executed Contract

Init.

.5 Addenda, if any:

Listing of Addenda, if any, to be included as attachment in Executed Contract

Portions of Addenda relating to bidding or proposal requirements are not part of the Contract Documents unless the bidding or proposal requirements are also enumerated in this Article 9.

.6 Other Exhibits:

(Check all boxes that apply and include appropriate information identifying the exhibit where required.)

(Paragraphs deleted)

§ 9.2

(Paragraph deleted)

Supplementary and other Conditions of the Contract:

Document	Title	Date	Pages
N/A			

§ 9.2.1 Other documents, if any, listed below:

(List here any additional documents that are intended to form part of the Contract Documents. AIA Document A201™-2017 provides that the advertisement or invitation to bid, Instructions to Bidders, sample forms, the Contractor's bid or proposal, portions of Addenda relating to bidding or proposal requirements, and other information furnished by the Owner in anticipation of receiving bids or proposals, are not part of the Contract Documents unless enumerated in this Agreement. Any such documents should be listed here only if intended to be part of the Contract Documents.)

BIDDING AND CONTRACT REQUIREMENTS

Section 00100	Invitation to Bid
Section 00200	Instructions to Bidders-AIA Document A701-2018
Section 00300	Supplementary Instructions to Bidders
Section 00400	Bid Form Accounting of Sales Tax Form C-3A Supplier Diversity Subcontracting and Major Supplier Plan
Section 00500	Standard Form of Agreement Between Owner and Contractor AIA Document A101
Section 00600	Bonds, Certificates and Affidavits Performance Bond Labor and Material Payment Bond E-Verify Documentation (Sample) Application and Certificate for Payment-AIA Document G702and G703 with DBE Utilization Report Certificate of Substantial Completion-AIA Document G704 Contractor's Affidavit of Payment of Debts and Claims- AIA Document G706 Contractor's Affidavit of Release of Liens-AIA Document G706A Consent of Surety to Final Payment-AIA Document G707 Request for Taxpayer Identification Number and Certification W9 Tax Form and City of Mobile Vendor Information Form
Section 00700	General Conditions of the Contract for Construction- AIA Document A201

§ 9.2.2 Best Management Practices (BMPs):

The Contractor shall be responsible for providing, implementing and maintaining BMPs for sediment and erosion control in full compliance with all applicable Local, State and Federal Codes and Ordinances

Init.

throughout the contract period. All Work shall be in accordance with the Clean Water Act; the Alabama Water Pollution Control Act; the current version of the Alabama Handbook for Erosion Control, Sediment Control Stormwater Management on Construction sites and Urban Areas; and the current version of the Mobile, Alabama City Code Chapter 17 Stormwater Management and Flood Control. All Waste water with oils, grease, paint, mortar, etc., shall be properly contained and disposed of.

§ 9.2.3 Contractor shall comply with all Federal, State and local laws concerning nondiscrimination, including but not limited to City of Mobile Ordinance No. 14-034 which requires, *inter alia*, that all contractors performing work for the City of Mobile not discriminate on the basis of race, creed, color, national origin or disability, require that all subcontractors they engage do the same, and make every reasonable effort to assure that fifteen percent of the work performed under contract be awarded to socially and economically disadvantaged individuals and business entities.

§ 9.2.4 By signing this contract, the contracting parties affirm, for the duration of the agreement, that they will not violate federal immigration law or knowingly employ, hire for employment, or continue to employ an unauthorized alien within the State of Alabama. Furthermore, a contracting party found to be in violation of this provision shall be deemed in breach of the agreement and shall be responsible for all damages resulting therefrom.

§ 9.2.5 Public Contracts with Entities Engaging in certain Boycott Activities:
By signing this contract, the Contractor further represents and agrees that it is not currently engaged in, nor will it engage in, any boycott of a person or entity based in or doing business with a jurisdiction with which the State of Alabama can enjoy open trade.

REMAINDER OF PAGE INTENTIONALLY LEFT BLANK

This Agreement entered into as of the day and year first written above.

City of Mobile

Legal Name of Party to Contract:
Contractor:

OWNER *(Signature)*

CONTRACTOR *(By Signature)*

William S. Stimpson, Mayor
(Rows deleted)
(Printed name and title)

(Printed name and title)

ATTEST:

City Clerk

STATE OF ALABAMA
COUNTY OF MOBILE

Before me, the undersigned a Notary Public in and for said County and State, personally appeared _____ as _____ of _____ and after being duly sworn, did depose and say that he, as such officer and with full authority, signed the above and foregoing voluntarily as the act of said corporation on the day the same bears date.
Sworn to and subscribed for me this _____ day of _____, 20 _____.

NOTARY PUBLIC

My Commission Expires: _____

00600 BONDS, CERTIFICATES AND AFFIDAVITS

PART 1 GENERAL

This section includes the Bond Forms and Certificates that are to be used on this Project. No other forms will be accepted. Forms may be obtained from the Architectural Engineering Department, City of Mobile, telephone number 251-208-7454.

1.1 FORMS

- A. PERFORMANCE BOND. Owner's modified Performance Bond form.
- B. LABOR AND MATERIAL PAYMENT BOND. Owner's modified Payment Bond form.
- C. E-VERIFY Documentation (Sample)
- D. APPLICATION AND CERTIFICATION FOR PAYMENT - AIA Document G702 and AIA Document G703
- E. DBE UTILIZATION REPORT
- F. CERTIFICATE of SUBSTANTIAL COMPLETION – AIA Document G704-2017
- G. CONTRACTOR'S AFFIDAVIT OF PAYMENT OF DEBTS AND CLAIMS - AIA Document G706
- H. CONTRACTOR'S AFFIDAVIT OF RELEASE OF LIENS - AIA Document G706A.
- I. CONSENT OF SURETY TO FINAL PAYMENT - AIA Document G707
- J. REQUEST FOR TAXPAYER IDENTIFICATION NUMBER AND CERTIFICATION - Form W-9,
- K. CITY OF MOBILE VENDOR INFORMATION FORM

LABOR AND MATERIAL PAYMENT BOND

Any singular reference to Contractor, Surety, Owner or other Party shall be considered plural where applicable.

KNOW ALL MEN BY THESE PRESENTS: That the Contractor, _____, as Principal, and _____, as Surety, are held and firmly bound unto the **City of Mobile, P. O. Box 1827, Mobile, AL 36633** (hereinafter called the "Obligee") in the penal sum of _____ Dollars and no cents (\$ _____) lawful money of the United States, for the payment of which sum well and truly to be made we bind ourselves, our heirs, personal representatives, successors, and assigns, jointly and severally, firmly by these presents.

WHEREAS, said Principal has entered into a certain Contract with said Obligee, dated the ____ day of _____, 2022, (hereinafter called the "Contract") for furnishing all labor, material, equipment and insurance and perform all work required to properly construct Crichton Fire Station – Drive Repair, FD-072-21, at 200 Davenport Ave., Mobile, Alabama 36607, which, **THEREFORE, THE CONDITION OF THIS OBLIGATION IS SUCH** that if said Principal and all subcontractors to whom any portion of work provided for in said Contract is sublet and all assignees of said Principal and of such subcontractors shall promptly make payments to all persons supplying him or them with labor, materials or supplies for or in the prosecution of the work provided for in such Contract, or in any amendment or extension of or additions to said Contract, and for the payment of reasonable attorney's fees, incurred by the claimant or claimants in suits on each bond, then the above obligations shall be void; otherwise to remain in full force and effect. **PROVIDED**, however, that this bond is subject to the following conditions and limitations.

- (a) Any person, firm or corporation that has furnished labor, materials or supplies for or in the prosecution of the work provided for in said contract shall have a direct right of action against the Principal and Surety on this bond, which right of action shall be asserted in a proceeding instituted in the County in which the work provided for in said Contract is to be performed or in any county in which said Principal and Surety does business. Such right of action shall be asserted in a proceeding instituted in the name of the claimant or claimants for his or their use and benefit against said Principal and Surety or either of them (but not later than one year after the final settlement of said Contract) in which action such claim or claims shall be adjudicated and judgment rendered thereon.
- (b) The Principal and Surety hereby designate and appoint _____ **Attorney-In-Fact**, as the agent of each of them to receive and accept service of process or other pleading issued or filed in any proceeding instituted on this bond and hereby consent that such service shall be the same as personal service on the Principal and/or Surety. In addition to any other legal mode of service, service of summons, and other process in civil actions brought in Mobile County may be had on the Contractor or the Surety on the bond by leaving a copy of the summons and complaint or other pleading or process with the Mayor of the City of Mobile which shall bind the principal Contractor and Surety to the mode of service above described and that the service shall be the same as personal service on the contractor or surety.
- (c) The Surety shall not be liable hereunder for damage or compensation recoverable under any Workmen's Compensation or Employer's Liability Statute.
- (d) In no event shall the Surety be liable for a greater sum than the penalty of this bond, or subject to any suit, action or proceeding thereon that is instituted later than two years after the final settlement of said Contract.
- (e) This bond is given pursuant to the terms of Alabama Code, Title 39-1-1, et. al., As Amended.

EXECUTED IN FOUR (4) COUNTERPARTS.

SIGNED, SEALED AND DELIVERED this ____ day of _____, 2022.

CONTRACTOR AS PRINCIPAL
Company: _____
(Corporate Seal)

SURETY
Company: _____
(Corporate Seal)

By: _____
(Signature)

By: _____
(Signature)

Name and Title: _____

Name and Title: _____

Resident Agent: _____
(Signature)

Name and Title: _____

Address: _____

Phone and Fax: _____

Owner's Representative: Cassie Boatwright, Director

Real Estate Asset Management
PO Box 1827
Mobile, AL 36633
251-208-7454

PERFORMANCE BOND

Any singular reference to Contractor, Surety, Owner or other Party shall be considered plural where applicable.

KNOW ALL MEN BY THESE PRESENTS: That the Contractor _____, hereinafter called the Principal, and _____, hereinafter called the Surety, are held and firmly bound unto the **City of Mobile, P. O. Box 1827, Mobile, AL 36633**, hereinafter called the Owner, in the penal sum of _____

_____ Dollars and no cents (\$ _____) for payment of which we bind ourselves, our heirs, executors, administrators, successors, and assigns for the faithful performance of a certain written Contract dated the _____ day of _____, 2022, entered into between the Principal and the City of Mobile for furnishing all labor, material, equipment and insurance and perform all Work required to properly construct Crichton Fire Station – Drive Repair, FD-072-21, at 200 Davenport Ave., Mobile, Alabama 36607, a copy of which said Contract is incorporated herein by reference and is made a part hereof as if fully copied herein.

NOW, THEREFORE, the condition of this obligation is such that if the Principal shall faithfully perform the terms and conditions of the Contract in all respects on its part and shall fully pay all obligations incurred in connection with the performance of such Contract on account of labor and materials used in connection therewith, and all such other obligations of every form, nature and character, and shall save harmless the Owner from all and any liability of every nature, kind and character which may be incurred in connection with the performance or fulfillment of such Contract or other such and liability resulting from negligence or otherwise on the part of such Principal and further save harmless the Owner from all cost and damage which may be suffered by reason of the failure to fully and completely perform said contract and shall fully reimburse and repay the Owner for all expenditures of every kind, character, and description which may be incurred by the Owner in making good any and every default which may exist on the part of the Principal in connection with the performance of said Contract; and further that the Principal shall pay all lawful claims of all persons, firms, partnerships, or corporations for all labor performed and material furnished in connection with the performance of the Contract, and that the failure to do so with such persons, firms, partnerships or corporations shall give them a direct obligation; and provided, however, that no suit, action, or proceedings by reason of any default whatever shall be brought on this bond after two years from the date on which the final payment on the Contract falls due, and provided, further, that if any alterations or additions which may be made under the Contract, or in the work to be done under it, or the giving by the Owner of any extensions of time for the performance of the Contract or any other forbearance being expressly waived. This obligation shall remain in full force and effect until the performance of all covenants, terms and conditions herein stipulated and after such performance, it shall become null and void.

In addition to any other legal mode of service, service of summons, and other process in civil actions brought in Mobile County may be had on the Contractor or the Surety on the bond by leaving a copy of the summons and complaint or other pleading or process with the Mayor of the City of Mobile which shall bind the principal Contractor and Surety to the mode of service above described and that the service shall be the same as personal service on the contractor or surety. This Bond is given pursuant to the terms of Alabama Code, Title 39-1-1, et. al., As Amended.

EXECUTED IN FOUR COUNTERPARTS.

SIGNED, SEALED AND DELIVERED this ____ day of _____, 2022.

CONTRACTOR AS PRINCIPAL

SURETY

Company: _____
(Corporate Seal)

Company: _____
(Corporate Seal)

By: _____
(Signature)

By: _____
(Signature)

Name and Title: _____

Name and Title: _____

Resident Agent: _____
(Signature)

Owner’s Representative: Cassie Boatwright, Director
Real Estate Asset Management
PO Box 1827
Mobile, AL 36633
251-208-7454

Name and Title: _____

Address: _____

Phone and Fax: _____

Company ID Number:

Approved by:

Employer	
Name (Please Type or Print)	Title
Signature	Date
Department of Homeland Security – Verification Division	
Name (Please Type or Print)	Title
Signature	Date

Company ID Number:

Information Required for the E-Verify Program	
Information relating to your Company:	
Company Name	
Company Facility Address	
Company Alternate Address	
County or Parish	
Employer Identification Number	
North American Industry Classification Systems Code	
Parent Company	
Number of Employees	
Number of Sites Verified for	

TO OWNER City of Mobile
 P. O. Box 1827
 Mobile, AL 36633-1827

PROJECT:

APPLICATION NO:

Distribution to:

<input type="checkbox"/>	OWNER
<input type="checkbox"/>	ARCHITECT
<input type="checkbox"/>	CONTRACTOR
<input type="checkbox"/>	
<input type="checkbox"/>	

PERIOD TO:

FROM CONTRACTOR:

VIA ARCHITECT:

PROJECT NO:

CONTRACT FOR:

CONTRACT DATE:

CONTRACTOR'S APPLICATION FOR PAYMENT

Application is made for payment, as shown below, in connection with the Contract. Continuation Sheet, AIA Document G703, is attached.

- 1. ORIGINAL CONTRACT SUM \$ _____
- 2. Net change by Change Orders \$ _____
- 3. CONTRACT SUM TO DATE (Line 1 + 2) \$ _____
- 4. TOTAL COMPLETED & STORED TO DATE (Column G on G703) \$ _____
- 5. RETAINAGE:
 - a. _____ % of Completed Work \$ _____
 (Column D + E on G703)
 - b. _____ % of Stored Material \$ _____
 (Column F on G703)
 - Total Retainage (Lines 5a + 5b or Total in Column I of G703) \$ _____
- 6. TOTAL EARNED LESS RETAINAGE (Line 4 Less Line 5 Total) \$ _____
- 7. LESS PREVIOUS CERTIFICATES FOR PAYMENT (Line 6 from prior Certificate) \$ _____
- 8. CURRENT PAYMENT DUE \$ _____
- 9. BALANCE TO FINISH, INCLUDING RETAINAGE (Line 3 less Line 6) \$ _____

The undersigned Contractor certifies that to the best of the Contractor's knowledge, information and belief the Work covered by this Application for Payment has been completed in accordance with the Contract Documents, that all amounts have been paid by the Contractor for Work for which previous Certificates for Payment were issued and payments received from the Owner, and that current payment shown herein is now due.

CONTRACTOR:

By: _____ Date: _____

State of: _____ County of: _____
 Subscribed and sworn to before me this _____ day of _____
 Notary Public:
 My Commission expires: _____

ARCHITECT'S CERTIFICATE FOR PAYMENT

In accordance with the Contract Documents, based on on-site observations and the data comprising the application, the Architect certifies to the Owner that to the best of the Architect's knowledge, information and belief the Work has progressed as indicated, the quality of the Work is in accordance with the Contract Documents, and the Contractor is entitled to payment of the AMOUNT CERTIFIED.

AMOUNT CERTIFIED \$ _____

(Attach explanation if amount certified differs from the amount applied. Initial all figures on this Application and on the Continuation Sheet that are changed to conform with the amount certified.)

ARCHITECT:

By: _____ Date: _____

This Certificate is not negotiable. The AMOUNT CERTIFIED is payable only to the Contractor named herein. Issuance, payment and acceptance of payment are without prejudice to any rights of the Owner or Contractor under this Contract.

CHANGE ORDER SUMMARY	ADDITIONS	DEDUCTIONS
Total changes approved in previous months by Owner		
Total approved this Month		
TOTALS		
NET CHANGES by Change Order		

CONTINUATION SHEET

AIA DOCUMENT G703

PAGE OF PAGES

AIA Document G702, APPLICATION AND CERTIFICATION FOR PAYMENT, containing Contractor's signed certification is attached.

APPLICATION NO:

APPLICATION DATE:

In tabulations below, amounts are stated to the nearest dollar.

PERIOD TO:

Use Column I on Contracts where variable retainage for line items may apply.

ARCHITECT'S PROJECT NO:

A ITEM NO.	B DESCRIPTION OF WORK	C SCHEDULED VALUE	D WORK COMPLETED		F MATERIALS PRESENTLY STORED (NOT IN D OR E)	G		H BALANCE TO FINISH (C - G)	I RETAINAGE (IF VARIABLE RATE)
			FROM PREVIOUS APPLICATION (D + E)	THIS PERIOD		TOTAL COMPLETED AND STORED TO DATE (D+E+F)	% (G ÷ C)		
GRAND TOTALS									

Users may obtain validation of this document by requesting of the license a completed AIA Document D401 - Certification of Document's Authenticity

OFFICE OF SUPPLIER DIVERSITY

CITY OF MOBILE

**DBE Compliance
DBE UTILIZATION REPORT**

Return to Office of Supplier Diversity
Via email: archnique.kidd@cityofmobile.org
or
P.O. Box 1948
Mobile, AL 36633

CONTRACTOR:	Certified DBE: YES NO	Contract Start Date:
--------------------	--	-----------------------------

DESCRIPTION:	Estimated Completion Date:
---------------------	-----------------------------------

This report is for the month of: (CHECK ONE):	JAN FEB MARCH	APR MAY JUNE	JULY AUG SEPT	OCT NOV DEC	FINAL _____
--	----------------------------	---------------------------	----------------------------	--------------------------	--------------------

Original Contract Amount	Total Amount of Contract Changes (change orders or amendments)	Final Contract Amount (include contract changes)	Payments to Date from City of Mobile	OFFICE USE ONLY (Verification)
\$	\$	\$	\$	

Instructions: List all DBEs utilized on the contract, whether or not the firms were originally listed for DBE goal credit. List actual amount paid to each DBE firm. If the established Percentage is not being met, please include a narrative description of the progress being made in DBE participation.

DBE SUBCONTRACTOR	DBE DESCRIPTION OF WORK	DBE SUBCONTRACT AMOUNT	DBE PAYMENTS THIS REPORT	PAYMENTS TO DATE	OFFICE USE ONLY (Verification)
		\$	\$	\$	
		\$	\$	\$	
		\$	\$	\$	
		\$	\$	\$	
TOTALS		\$	\$	\$	

I HEREBY CERTIFY THAT THE INFORMATION CONTAINED HEREIN IS TRUE AND CORRECT. SUPPORTING DOCUMENTATION IS ON FILE AND IS AVAILABLE FOR INSPECTION BY CITY OF MOBILE OFFICE OF SUPPLIER DIVERSITY PERSONNEL AT ANY TIME.

PRINT NAME: _____

SIGNATURE: _____ /_____/_____
(Title) (Date)

DBE Utilization Report



AIA[®]

Document G704[™] – 2000

Certificate of Substantial Completion

PROJECT: *(Name and address)*

PROJECT NUMBER:

CONTRACT FOR:

CONTRACT DATE:

TO OWNER: *(Name and address)*

TO CONTRACTOR: *(Name and address)*

OWNER

ARCHITECT

CONTRACTOR

FIELD

OTHER

PROJECT OR PORTION OF THE PROJECT DESIGNATED FOR PARTIAL OCCUPANCY OR USE SHALL INCLUDE:

The Work performed under this Contract has been reviewed and found, to the Architect's best knowledge, information and belief, to be substantially complete. Substantial Completion is the stage in the progress of the Work when the Work or designated portion is sufficiently complete in accordance with the Contract Documents so that the Owner can occupy or utilize the Work for its intended use. The date of Substantial Completion of the Project or portion designated above is the date of issuance established by this Certificate, which is also the date of commencement of applicable warranties required by the Contract Documents, except as stated below:

ARCHITECT

BY

DATE OF ISSUANCE

A list of items to be completed or corrected is attached hereto. The failure to include any items on such list does not alter the responsibility of the Contractor to complete all Work in accordance with the Contract Documents. Unless otherwise agreed to in writing, the date of commencement of warranties for items on the attached list will be the date of issuance of the final Certificate of Payment or the date of final payment.

Cost estimate of Work that is incomplete or defective: \$ _____

The Contractor will complete or correct the Work on the list of items attached hereto within () days from the above date of Substantial Completion.

CONTRACTOR

BY

DATE

The Owner accepts the Work or designated portion as substantially complete and will assume full possession at (time) on (date).

OWNER

BY

DATE

The responsibilities of the Owner and Contractor for security, maintenance, heat, utilities, damage to the Work and insurance shall be as follows: *(Note: Owner's and Contractor's legal and insurance counsel should determine and review insurance requirements and coverage.)*



AIA[®] Document G706[™] – 1994

Contractor's Affidavit of Payment of Debts and Claims

PROJECT: *(Name and address)*

ARCHITECT'S PROJECT NUMBER:

OWNER:

ARCHITECT:

TO OWNER: *(Name and address)*

CONTRACT FOR: General Construction

CONTRACTOR:

CONTRACT DATED:

SURETY:

OTHER:

STATE OF:

COUNTY OF:

The undersigned hereby certifies that, except as listed below, payment has been made in full and all obligations have otherwise been satisfied for all materials and equipment furnished, for all work, labor, and services performed, and for all known indebtedness and claims against the Contractor for damages arising in any manner in connection with the performance of the Contract referenced above for which the Owner or Owner's property might in any way be held responsible or encumbered.

EXCEPTIONS:

SUPPORTING DOCUMENTS ATTACHED HERETO:

1. Consent of Surety to Final Payment. Whenever Surety is involved, Consent of Surety is required. AIA Document G707, Consent of Surety, may be used for this purpose

Indicate Attachment Yes No

CONTRACTOR: *(Name and address)*

The following supporting documents should be attached hereto if required by the Owner:

1. Contractor's Release or Waiver of Liens, conditional upon receipt of final payment.
2. Separate Releases or Waivers of Liens from Subcontractors and material and equipment suppliers, to the extent required by the Owner, accompanied by a list thereof.
3. Contractor's Affidavit of Release of Liens (AIA Document G706A).

BY:

(Signature of authorized representative)

(Printed name and title)

Subscribed and sworn to before me on this date:

Notary Public:

My Commission Expires:



AIA[®] Document G706A[™] – 1994

Contractor's Affidavit of Release of Liens

PROJECT: <i>(Name and address)</i>	ARCHITECT'S PROJECT NUMBER:	OWNER: <input type="checkbox"/>
	CONTRACT FOR: General Construction	ARCHITECT: <input type="checkbox"/>
TO OWNER: <i>(Name and address)</i>	CONTRACT DATED:	CONTRACTOR: <input type="checkbox"/>
		SURETY: <input type="checkbox"/>
		OTHER: <input type="checkbox"/>

STATE OF:
COUNTY OF:

The undersigned hereby certifies that to the best of the undersigned's knowledge, information and belief, except as listed below, the Releases or Waivers of Lien attached hereto include the Contractor, all Subcontractors, all suppliers of materials and equipment, and all performers of Work, labor or services who have or may have liens or encumbrances or the right to assert liens or encumbrances against any property of the Owner arising in any manner out of the performance of the Contract referenced above.

EXCEPTIONS:

SUPPORTING DOCUMENTS ATTACHED HERETO:

1. Contractor's Release or Waiver of Liens, conditional upon receipt of final payment.
2. Separate Releases or Waivers of Liens from Subcontractors and material and equipment suppliers, to the extent required by the Owner, accompanied by a list thereof.

CONTRACTOR: *(Name and address)*

BY: _____

(Signature of authorized representative)

(Printed name and title)

Subscribed and sworn to before me on this date:

Notary Public:

My Commission Expires:



AIA[®] Document G707[™] – 1994

Consent Of Surety to Final Payment

PROJECT: *(Name and address)*

ARCHITECT'S PROJECT NUMBER:

OWNER:

CONTRACT FOR: General Construction

ARCHITECT:

TO OWNER: *(Name and address)*

CONTRACT DATED:

CONTRACTOR:

SURETY:

OTHER:

In accordance with the provisions of the Contract between the Owner and the Contractor as indicated above, the
(Insert name and address of Surety)

on bond of
(Insert name and address of Contractor)

, SURETY,

hereby approves of the final payment to the Contractor, and agrees that final payment to the Contractor shall not relieve the
Surety of any of its obligations to
(Insert name and address of Owner)

, CONTRACTOR,

as set forth in said Surety's bond.

, OWNER,

IN WITNESS WHEREOF, the Surety has hereunto set its hand on this date:
(Insert in writing the month followed by the numeric date and year.)

(Surety)

(Signature of authorized representative)

(Printed name and title)

Attest:

(Seal):

CITY OF MOBILE, AL
VENDOR INFORMATION FORM

Company Information:

1. City Vendor Number:

2. Name of Company:

3. Company D.B.A. Name, if any:

4. Mailing Address:

5. Remittance Address:

6. Telephone:

7. Fax

8. Main Email:

Primary Contact:

9. Contact Name and Title:

10. Contact Phone:

11. Contact Fax:

12. Contact Email:

Alternate Contact (if applicable):

13. Alt. Contact Name and Title:

14. Alt. Contact Phone:

15. Alt. Contact Fax:

16. Alt. Contact Email:

City of Mobile Business License Information:

17. City of Mobile Business License No. (if required):

Please attach additional sheets if necessary.

**SECTION 00700
GENERAL CONDITIONS OF THE CONTRACT FOR CONSTRUCTION**

PART 1 GENERAL

A. This section includes the GENERAL CONDITIONS OF THE CONTRACT FOR CONSTRUCTION, AIA Document A201-2007 that are to be used for this Project.



AIA[®]

Document A201™ – 2007

General Conditions of the Contract for Construction

for the following PROJECT:

(Name and location or address)

CRICHTON FIRE STATION - DRIVE REPAIR
200 Davenport Avenue, Mobile, Alabama 36607
FD-072-21

THE OWNER:

(Name, legal status and address)

City of Mobile

Architectural Engineering Department

P. O. Box 1827

Mobile, Alabama 36633-1827

THE ARCHITECT:

(Name, legal status and address)

Watermark Design Group, LLC

2970 Cottage Hill Road, Suite 200

Mobile, Alabama 36606

TABLE OF ARTICLES

- 1 GENERAL PROVISIONS
- 2 OWNER
- 3 CONTRACTOR
- 4 ARCHITECT
- 5 SUBCONTRACTORS
- 6 CONSTRUCTION BY OWNER OR BY SEPARATE CONTRACTORS
- 7 CHANGES IN THE WORK
- 8 TIME
- 9 PAYMENTS AND COMPLETION
- 10 PROTECTION OF PERSONS AND PROPERTY
- 11 INSURANCE AND BONDS
- 12 UNCOVERING AND CORRECTION OF WORK
- 13 MISCELLANEOUS PROVISIONS
- 14 TERMINATION OR SUSPENSION OF THE CONTRACT
- 15 CLAIMS AND DISPUTES

This document has important legal consequences. Consultation with an attorney is encouraged with respect to its completion or modification.

Int.

AIA Document A201™ – 2007. Copyright © 1911, 1915, 1918, 1925, 1937, 1951, 1958, 1961, 1963, 1966, 1970, 1976, 1987, 1997 and 2007 by The American Institute of Architects. All rights reserved. WARNING: This AIA[®] Document is protected by U.S. Copyright Law and International Treaties. Unauthorized reproduction or distribution of this AIA[®] Document, or any portion of it, may result in severe civil and criminal penalties, and will be prosecuted to the maximum extent possible under the law. This document was produced by AIA software at 15:13:02 on 07/19/2017 under Order No.7986168957_1 which expires on 08/01/2017, and is not for resale.

User Notes:

(1383218234)

INDEX

(Topics and numbers in bold are section headings)
(Numbers and Topics in Bold are Section Headings)

Acceptance of Nonconforming Work

9.6.6, 9.9.3, **12.3**

Acceptance of Work

9.6.6, 9.8.2, 9.9.3, 9.10.1, 9.10.3, **12.3**

Access to Work

3.16, 6.2.1, **12.1**

Accident Prevention

10

Acts and Omissions

3.2, 3.3.2, 3.12.8, 3.18, 4.2.3, 8.3.1, 9.5.1, 10.2.5, 10.2.8, 13.4.2, ~~13.7~~, **13.7.1**, 14.1, 15.2

Addenda

1.1.1, ~~3.11.1~~

Additional Costs, Claims for

3.7.4, 3.7.5, 6.1.1, 7.3.7.5, 10.3, 15.1.4

Additional Inspections and Testing

9.4.2, 9.8.3, 12.2.1, **13.5**

Additional Insured

11.1.4

Additional Time, Claims for

3.2.4, 3.7.4, 3.7.5, 3.10.2, 8.3.2, **15.1.5**

Administration of the Contract

3.1.3, **4.2**, 9.4, 9.5

Advertisement or Invitation to Bid

1.1.1

Aesthetic Effect

4.2.13

Allowances

3.8, 7.3.8

All-risk Insurance

11.3.1, 11.3.1.1

Applications for Payment

4.2.5, 7.3.9, 9.2, **9.3**, 9.4, 9.5.1, 9.6.3, ~~9.7~~, **9.7.1**, 9.10, 11.1.3

Approvals

2.1.1, 2.2.2, 2.4, 3.1.3, 3.10.2, 3.12.8, 3.12.9, 3.12.10, 4.2.7, 9.3.2, 13.5.1

Arbitration

8.3.1, 11.3.10, ~~13.1~~, **13.1.1**, 15.3.2, **15.4**

ARCHITECT

4

Architect, Definition of

4.1.1

Architect, Extent of Authority

~~2.4~~, ~~2.4.1~~, 3.12.7, 4.1, 4.2, 5.2, ~~6.3~~, ~~6.3.1~~, 7.1.2, 7.3.7, 7.4, ~~9.2~~, ~~9.2.1~~, 9.3.1, 9.4, 9.5, 9.6.3, 9.8, 9.10.1, 9.10.3, 12.1, 12.2.1, 13.5.1, 13.5.2, 14.2.2, 14.2.4, 15.1.3, 15.2.1

Architect, Limitations of Authority and Responsibility

2.1.1, 3.12.4, 3.12.8, 3.12.10, 4.1.2, 4.2.1, 4.2.2, 4.2.3, 4.2.6, 4.2.7, 4.2.10, 4.2.12, 4.2.13, 5.2.1, ~~7.4~~, ~~7.4.1~~, 9.4.2, 9.5.3, 9.6.4, 15.1.3, 15.2

Architect's Additional Services and Expenses

~~2.4~~, ~~2.4.1~~, 11.3.1.1, 12.2.1, 13.5.2, 13.5.3, 14.2.4

Architect's Administration of the Contract

3.1.3, 4.2, 3.7.4, 15.2, 9.4.1, 9.5

Architect's Approvals

~~2.4~~, ~~3.1.3~~, ~~3.5~~, ~~2.4.1~~, 3.1.3, **3.5.1**, 3.10.2, 4.2.7

Architect's Authority to Reject Work

~~3.5~~, **3.5.1**, 4.2.6, 12.1.2, 12.2.1

Architect's Copyright

1.1.7, 1.5

Architect's Decisions

3.7.4, 4.2.6, 4.2.7, 4.2.11, 4.2.12, 4.2.13, 4.2.14, ~~6.3~~, ~~6.3.1~~, 7.3.7, 7.3.9, 8.1.3, 8.3.1, ~~9.2~~, ~~9.2.1~~, 9.4.1, 9.5, 9.8.4, 9.9.1, 13.5.2, 15.2, 15.3

Architect's Inspections

3.7.4, 4.2.2, 4.2.9, 9.4.2, 9.8.3, 9.9.2, 9.10.1, 13.5

Architect's Instructions

3.2.4, 3.3.1, 4.2.6, 4.2.7, 13.5.2

Architect's Interpretations

4.2.11, 4.2.12

Architect's Project Representative

4.2.10

Architect's Relationship with Contractor

1.1.2, 1.5, 3.1.3, 3.2.2, 3.2.3, 3.2.4, 3.3.1, 3.4.2, ~~3.5~~, ~~3.5.1~~, 3.7.4, 3.7.5, 3.9.2, 3.9.3, 3.10, 3.11, 3.12, 3.16, 3.18, 4.1.2, 4.1.3, 4.2, 5.2, 6.2.2, 7, 8.3.1, 9.2, 9.3, 9.4, 9.5, 9.7, 9.8, 9.9, 10.2.6, 10.3, 11.3.7, 12, 13.4.2, 13.5, 15.2

Architect's Relationship with Subcontractors

1.1.2, 4.2.3, 4.2.4, 4.2.6, 9.6.3, 9.6.4, 11.3.7

Architect's Representations

9.4.2, 9.5.1, 9.10.1

Architect's Site Visits

3.7.4, 4.2.2, 4.2.9, 9.4.2, 9.5.1, 9.9.2, 9.10.1, 13.5

Asbestos

10.3.1

Attorneys' Fees

3.18.1, 9.10.2, 10.3.3

Award of Separate Contracts

6.1.1, 6.1.2

Award of Subcontracts and Other Contracts for Portions of the Work

5.2

Basic Definitions

1.1

Bidding Requirements

1.1.1, 5.2.1, 11.4.1

Binding Dispute Resolution

~~9.7~~, ~~9.7.1~~, 11.3.9, 11.3.10, ~~13.1~~, **13.1.1**, 15.2.5, 15.2.6.1, 15.3.1, 15.3.2, 15.4.1

Int.

Boiler and Machinery Insurance**11.3.2**

Bonds, Lien

7.3.7.4, 9.10.2, 9.10.3

Bonds, Performance, and Payment

7.3.7.4, 9.6.7, 9.10.3, 11.3.9, 11.4

Building Permit

3.7.1

Capitalization**1.3**

Certificate of Substantial Completion

9.8.3, 9.8.4, 9.8.5

Certificates for Payment

4.2.1, 4.2.5, 4.2.9, 9.3.3, 9.4, 9.5, 9.6.1, 9.6.6, 9.7,

9.7.1, 9.10.1, 9.10.3, 14.1.1.3, 14.2.4, 15.1.3

Certificates of Inspection, Testing or Approval

13.5.4

Certificates of Insurance

9.10.2, 11.1.3

Change Orders1.1.1, ~~2.4~~, ~~2.4.1~~, 3.4.2, 3.7.4, 3.8.2.3, ~~3.11~~, ~~3.11.1~~,

3.12.8, 4.2.8, 5.2.3, 7.1.2, 7.1.3, 7.2, 7.3.2, 7.3.6,

7.3.9, 7.3.10, 8.3.1, 9.3.1.1, 9.10.3, 10.3.2, 11.3.1.2,

11.3.4, 11.3.9, 12.1.2, 15.1.3

Change Orders, Definition of

7.2.1

CHANGES IN THE WORK2.2.1, 3.11, 4.2.8, 7, 7.2.1, 7.3.1, 7.4, 7.4.1, 8.3.1,

9.3.1.1, 11.3.9

Claims, Definition of

15.1.1**CLAIMS AND DISPUTES**3.2.4, 6.1.1, ~~6.2~~, ~~6.3.1~~, 7.3.9, 9.3.3, 9.10.4, 10.3.3, 15,

15.4

Claims and Timely Assertion of Claims

15.4.1

Claims for Additional Cost

3.2.4, 3.7.4, 6.1.1, 7.3.9, 10.3.2, 15.1.4

Claims for Additional Time

3.2.4, 3.7.4, ~~6.1.1~~, 3.7.46.1.1, 8.3.2, 10.3.2, 15.1.5

Concealed or Unknown Conditions, Claims for

3.7.4

Claims for Damages

3.2.4, 3.18, 6.1.1, 8.3.3, 9.5.1, 9.6.7, 10.3.3, 11.1.1,

11.3.5, 11.3.7, 14.1.3, 14.2.4, 15.1.6

Claims Subject to Arbitration

15.3.1, 15.4.1

Cleaning Up

3.15.6.3

Commencement of the Work, Conditions Relating to

2.2.1, 3.2.2, 3.4.1, 3.7.1, 3.10.1, 3.12.6, 5.2.1, 5.2.3,

6.2.2, 8.1.2, 8.2.2, 8.3.1, 11.1, 11.3.1, 11.3.6, 11.4.1,

15.1.4

Commencement of the Work, Definition of

8.1.2**Communications Facilitating Contract****Administration**

3.9.1, 4.2.4

Completion, Conditions Relating to

3.4.1, 3.11, 3.15, 4.2.2, 4.2.9, 8.2, 9.4.2, 9.8, 9.9.1,

9.10, 12.2, 13.7, 14.1.2

COMPLETION, PAYMENTS AND**9**

Completion, Substantial

4.2.9, 8.1.1, 8.1.3, 8.2.3, 9.4.2, 9.8, 9.9.1, 9.10.3,

12.2, 13.7

Compliance with Laws

~~1.6~~, ~~1.6.1~~, 3.2.3, 3.6, 3.7, 3.12.10, 3.13, 4.1.1, 9.6.4,

10.2.2, 11.1, 11.3, 13.1, 13.4, 13.5.1, 13.5.2, 13.6,

14.1.1, 14.2.1.3, 15.2.8, 15.4.2, 15.4.3

Concealed or Unknown Conditions

3.7.4, 4.2.8, 8.3.1, 10.3

Conditions of the Contract

1.1.1, 6.1.1, 6.1.4

Consent, Written

3.4.2, 3.7.4, 3.12.8, 3.14.2, 4.1.2, 9.3.2, 9.8.5, 9.9.1,

9.10.2, 9.10.3, 11.3.1, 13.2, 13.4.2, 15.4.4.2

Consolidation or Joinder

15.4.4**CONSTRUCTION BY OWNER OR BY****SEPARATE CONTRACTORS**

1.1.4, 6

Construction Change Directive, Definition of

7.3.1

Construction Change Directives

1.1.1, 3.4.2, 3.12.8, 4.2.8, 7.1.1, 7.1.2, 7.1.3, 7.3,

9.3.1.1

Construction Schedules, Contractor's

3.10, 3.12.1, 3.12.2, 6.1.3, 15.1.5.2

Contingent Assignment of Subcontracts

5.4, 14.2.2.2

Continuing Contract Performance

15.1.3

Contract, Definition of

1.1.2**CONTRACT, TERMINATION OR****SUSPENSION OF THE**

5.4.1.1, 11.3.9, 14

Contract Administration

3.1.3, 4, 9.4, 9.5

Contract Award and Execution, Conditions Relating

to

3.7.1, 3.10, 5.2, 6.1, 11.1.3, 11.3.6, 11.4.1

Contract Documents, The**1.1.1**Contract Documents, Copies Furnished and Use of

1.5.2, 2.2.5, 5.3

Contract Documents, Definition of

1.1.1

Inf.

AIA Document A201™ – 2007. Copyright © 1911, 1915, 1918, 1925, 1937, 1951, 1958, 1961, 1963, 1966, 1970, 1976, 1987, 1997 and 2007 by The American Institute of Architects. All rights reserved. WARNING: This AIA® Document is protected by U.S. Copyright Law and International Treaties. Unauthorized reproduction or distribution of this AIA® Document, or any portion of it, may result in severe civil and criminal penalties, and will be prosecuted to the maximum extent possible under the law. This document was produced by AIA software at 15:13:02 on 07/19/2017 under Order No.7986168957_1 which expires on 08/01/2017, and is not for resale.

User Notes:

(1383216234)

Contract Sum

3.7.4, 3.8, 5.2.3, 7.2, 7.3, 7.4, 9.1, 9.4.2, 9.5.1.4, 9.6.7, 9.7, 10.3.2, 11.3.1, 14.2.4, 14.3.2, 15.1.4, 15.2.5

Contract Sum, Definition of**9.1****Contract Time**

3.7.4, 3.7.5, 3.10.2, 5.2.3, 7.2.1.3, 7.3.1, 7.3.5, 7.4, 8.1.1, 8.2.1, 8.3.1, 9.5.1, ~~9.7, 9.7.1~~, 10.3.2, 12.1.1, 14.3.2, 15.1.5.1, 15.2.5

Contract Time, Definition of**8.1.1****CONTRACTOR****3****Contractor, Definition of****3.1, 6.1.2****Contractor's Construction Schedules**

3.10, 3.12.1, 3.12.2, 6.1.3, 15.1.5.2

Contractor's Employees

3.3.2, 3.4.3, 3.8.1, 3.9, 3.18.2, 4.2.3, 4.2.6, 10.2, 10.3, 11.1.1, 11.3.7, 14.1, ~~14.2.1, 14.2.1.1~~

Contractor's Liability Insurance**11.1****Contractor's Relationship with Separate Contractors and Owner's Forces**

3.12.5, 3.14.2, 4.2.4, 6, 11.3.7, 12.1.2, 12.2.4

Contractor's Relationship with Subcontractors

1.2.2, 3.3.2, 3.18.1, 3.18.2, 5, 9.6.2, 9.6.7, 9.10.2, 11.3.1.2, 11.3.7, 11.3.8

Contractor's Relationship with the Architect

1.1.2, 1.5, 3.1.3, 3.2.2, 3.2.3, 3.2.4, 3.3.1, 3.4.2, ~~3.5, 3.5.1~~, 3.7.4, 3.10, 3.11, 3.12, 3.16, 3.18, 4.1.3, 4.2, 5.2, 6.2.2, 7, 8.3.1, 9.2, 9.3, 9.4, 9.5, 9.7, 9.8, 9.9, 10.2.6, 10.3, 11.3.7, 12, 13.5, 15.1.2, 15.2.1

Contractor's Representations

3.2.1, 3.2.2, ~~3.5, 3.5.1~~, 3.12.6, 6.2.2, 8.2.1, 9.3.3, 9.8.2

Contractor's Responsibility for Those Performing the Work

3.3.2, 3.18, ~~5.3, 5.3.1~~, 6.1.3, 6.2, 9.5.1, 10.2.8

Contractor's Review of Contract Documents**3.2****Contractor's Right to Stop the Work****9.7****Contractor's Right to Terminate the Contract**

14.1, 15.1.6

Contractor's Submittals

3.10, 3.11, 3.12.4, 4.2.7, 5.2.1, 5.2.3, 9.2, 9.3, 9.8.2, 9.8.3, 9.9.1, 9.10.2, 9.10.3, 11.1.3, 11.4.2

Contractor's Superintendent

3.9, 10.2.6

Contractor's Supervision and Construction**Procedures**

1.2.2, 3.3, 3.4, 3.12.10, 4.2.2, 4.2.7, 6.1.3, 6.2.4, 7.1.3, 7.3.5, 7.3.7, 8.2, 10, 12, 14, 15.1.3

Contractual Liability Insurance

11.1.1.8, 11.2

Coordination and Correlation

1.2, 3.2.1, 3.3.1, 3.10, 3.12.6, 6.1.3, 6.2.1

Copies Furnished of Drawings and Specifications

1.5, 2.2.5, 3.11

Copyrights

1.5, 3.17

Correction of Work

2.3, 2.4, 3.7.3, 9.4.2, 9.8.2, 9.8.3, 9.9.1, 12.1.2, 12.2

Correlation and Intent of the Contract Documents**1.2****Cost, Definition of****7.3.7****Costs**

~~2.4, 2.4.1~~, 3.2.4, 3.7.3, 3.8.2, 3.15.2, 5.4.2, 6.1.1, 6.2.3, 7.3.3.3, 7.3.7, 7.3.8, 7.3.9, 9.10.2, 10.3.2, 10.3.6, 11.3, 12.1.2, 12.2.1, 12.2.4, 13.5, 14

Cutting and Patching

3.14, 6.2.5

Damage to Construction of Owner or Separate**Contractors**

3.14.2, 6.2.4, 10.2.1.2, 10.2.5, 10.4, 11.1.1, 11.3, 12.2.4

Damage to the Work

3.14.2, 9.9.1, 10.2.1.2, 10.2.5, ~~10.4, 10.4.1~~, 11.3.1, 12.2.4

Damages, Claims for

3.2.4, 3.18, 6.1.1, 8.3.3, 9.5.1, 9.6.7, 10.3.3, 11.1.1, 11.3.5, 11.3.7, 14.1.3, 14.2.4, 15.1.6

Damages for Delay

6.1.1, 8.3.3, 9.5.1.6, 9.7, 10.3.2

Date of Commencement of the Work, Definition of**8.1.2****Date of Substantial Completion, Definition of****8.1.3****Day, Definition of****8.1.4****Decisions of the Architect**

3.7.4, 4.2.6, 4.2.7, 4.2.11, 4.2.12, 4.2.13, 15.2, 6.3, 7.3.7, 7.3.9, 8.1.3, 8.3.1, ~~9.2, 9.2.1~~, 9.4, 9.5.1, 9.8.4, 9.9.1, 13.5.2, 14.2.2, 14.2.4, 15.1, 15.2

Decisions to Withhold Certification

9.4.1, 9.5, 9.7, 14.1.1.3

Defective or Nonconforming Work, Acceptance, Rejection and Correction of

~~2.3, 2.4, 3.5, 2.3.1, 2.4.1, 3.5.1~~, 4.2.6, 6.2.5, 9.5.1, 9.5.2, 9.6.6, 9.8.2, 9.9.3, 9.10.4, 12.2.1

Defective Work, Definition of**3.5.1****Definitions**

1.1, 2.1.1, 3.1.1, ~~3.5, 3.5.1~~, 3.12.1, 3.12.2, 3.12.3, 4.1.1, 15.1.1, 5.1, 6.1.2, 7.2.1, 7.3.1, 8.1, 9.1, 9.8.1

Delays and Extensions of Time

~~3.2, 3.2.1~~, 3.7.4, 5.2.3, 7.2.1, 7.3.1, ~~7.4, 7.4.1~~, 8.3, 9.5.1, 9.7, ~~10.3.2, 10.4, 9.7.1, 10.3.2, 10.4.1~~, 14.3.2, 15.1.5, 15.2.5

Disputes

~~6.3, 6.3.1~~, 7.3.9, 15.1, 15.2

Init.

AIA Document A201™ – 2007. Copyright © 1911, 1915, 1918, 1925, 1937, 1951, 1958, 1961, 1963, 1966, 1970, 1976, 1987, 1997 and 2007 by The American Institute of Architects. All rights reserved. WARNING: This AIA® Document is protected by U.S. Copyright Law and International Treaties. Unauthorized reproduction or distribution of this AIA® Document, or any portion of it, may result in severe civil and criminal penalties, and will be prosecuted to the maximum extent possible under the law. This document was produced by AIA software at 15:13:02 on 07/19/2017 under Order No.7986168957_1 which expires on 08/01/2017, and is not for resale.

User Notes:

(1383216234)

Documents and Samples at the Site

3.11

Drawings, Definition of

1.1.5

Drawings and Specifications, Use and Ownership of
3.11

Effective Date of Insurance

8.2.2, 11.1.2

Emergencies

10.4, 14.1.1.2, 15.1.4

Employees, Contractor's

3.3.2, 3.4.3, 3.8.1, 3.9, 3.18.2, 4.2.3, 4.2.6, 10.2,
10.3.3, 11.1.1, 11.3.7, 14.1, 14.2.1.1

Equipment, Labor, Materials or

1.1.3, 1.1.6, 3.4, ~~3.5~~, ~~3.5.1~~, 3.8.2, 3.8.3, 3.12, ~~3.13~~,
~~3.13.1~~, 3.15.1, 4.2.6, 4.2.7, 5.2.1, 6.2.1, 7.3.7, 9.3.2,
9.3.3, 9.5.1.3, 9.10.2, 10.2.1, 10.2.4, 14.2.1.1,
14.2.1.2

Execution and Progress of the Work

1.1.3, 1.2.1, 1.2.2, 2.2.3, 2.2.5, 3.1, 3.3.1, 3.4.1, ~~3.5~~,
~~3.5.1~~, 3.7.1, 3.10.1, 3.12, 3.14, 4.2, 6.2.2, 7.1.3, 7.3.5,
8.2, 9.5.1, 9.9.1, 10.2, 10.3, 12.2, 14.2, 14.3.1, 15.1.3

Extensions of Time

3.2.4, 3.7.4, 5.2.3, 7.2.1, 7.3, 7.4, ~~9.5.1~~, ~~9.7~~, ~~10.3.2~~,
~~10.4~~, 7.4.1, 9.5.1, 9.7.1, 10.3.2, 10.4.1, 14.3, 15.1.5,
15.2.5

Failure of Payment

9.5.1.3, 9.7, 9.10.2, 13.6, 14.1.1.3, 14.2.1.2

Faulty Work

(See Defective or Nonconforming Work)

Final Completion and Final Payment

4.2.1, 4.2.9, 9.8.2, 9.10, 11.1.2, 11.1.3, 11.3.1, 11.3.5,
~~12.3~~, ~~12.3.1~~, 14.2.4, 14.4.3

Financial Arrangements, Owner's

2.2.1, 13.2.2, 14.1.1.4

Fire and Extended Coverage Insurance

11.3.1.1

GENERAL PROVISIONS

1

Governing Law

13.1

Guarantees (See Warranty)

Hazardous Materials

10.2.4, 10.3

Identification of Subcontractors and Suppliers

5.2.1

Indemnification

~~3.17~~, ~~3.17.1~~, 3.18, 9.10.2, 10.3.3, 10.3.5, 10.3.6,
11.3.1.2, 11.3.7

Information and Services Required of the Owner

2.1.2, 2.2, 3.2.2, 3.12.4, 3.12.10, 6.1.3, 6.1.4, 6.2.5,
9.6.1, 9.6.4, 9.9.2, 9.10.3, 10.3.3, 11.2, 11.4, 13.5.1,
13.5.2, 14.1.1.4, 14.1.4, 15.1.3

Initial Decision

15.2

Initial Decision Maker, Definition of

1.1.8

Initial Decision Maker, Decisions

14.2.2, 14.2.4, 15.2.1, 15.2.2, 15.2.3, 15.2.4, 15.2.5

Initial Decision Maker, Extent of Authority

14.2.2, 14.2.4, 15.1.3, 15.2.1, 15.2.2, 15.2.3, 15.2.4,
15.2.5

Injury or Damage to Person or Property

10.2.8, ~~10.4~~10.4.1

Inspections

3.1.3, 3.3.3, 3.7.1, 4.2.2, 4.2.6, 4.2.9, 9.4.2, 9.8.3,
9.9.2, 9.10.1, 12.2.1, 13.5

Instructions to Bidders

1.1.1

Instructions to the Contractor

3.2.4, 3.3.1, 3.8.1, 5.2.1, 7, 8.2.2, 12, 13.5.2

Instruments of Service, Definition of

1.1.7

Insurance

3.18.1, 6.1.1, 7.3.7, 9.3.2, 9.8.4, 9.9.1, 9.10.2, 11

Insurance, Boiler and Machinery

11.3.2

Insurance, Contractor's Liability

11.1

Insurance, Effective Date of

8.2.2, 11.1.2

Insurance, Loss of Use

11.3.3

Insurance, Owner's Liability

11.2

Insurance, Property

10.2.5, 11.3

Insurance, Stored Materials

~~9.3.2~~, ~~9.3.2~~, 11.4.1.4

INSURANCE AND BONDS

11

Insurance Companies, Consent to Partial Occupancy

~~9.9.1~~, ~~9.9.1~~, 11.4.1.5

Insurance Companies, Settlement with

11.4.10

Intent of the Contract Documents

1.2.1, 4.2.7, 4.2.12, 4.2.13, 7.4

Interest

13.6

Interpretation

1.2.3, 1.4, 4.1.1, 5.1, 6.1.2, 15.1.1

Interpretations, Written

4.2.11, 4.2.12, 15.1.4

Judgment on Final Award

15.4.2

Labor and Materials, Equipment

1.1.3, 1.1.6, 3.4, ~~3.5~~, ~~3.5.1~~, 3.8.2, 3.8.3, 3.12, 3.13,
3.15.1, 4.2.6, 4.2.7, 5.2.1, 6.2.1, 7.3.7, 9.3.2, 9.3.3,
9.5.1.3, 9.10.2, 10.2.1, 10.2.4, 14.2.1.1, 14.2.1.2

Labor Disputes

8.3.1

Int.

Laws and Regulations

1.5, 3.2.3, 3.6, 3.7, 3.12.10, ~~3.13~~, ~~3.13.1~~, 4.1.1, 9.6.4, 9.9.1, 10.2.2, 11.1.1, 11.3, ~~13.1~~, ~~13.1.1~~, 13.4, 13.5.1, 13.5.2, ~~13.6~~, ~~13.6.1~~, 14, 15.2.8, 15.4

Liens

2.1.2, 9.3.3, 9.10.2, 9.10.4, 15.2.8

Limitations, Statutes of

12.2.5, 13.7, 15.4.1.1

Limitations of Liability

~~2.3~~, ~~3.2.2~~, ~~3.5~~, ~~3.12.10~~, ~~3.17~~, ~~2.3.1~~, ~~3.2.2~~, ~~3.5.1~~, ~~3.12.10~~, ~~3.17.1~~, 3.18.1, 4.2.6, 4.2.7, 4.2.12, 6.2.2, 9.4.2, 9.6.4, 9.6.7, 10.2.5, 10.3.3, 11.1.2, 11.2, 11.3.7, 12.2.5, 13.4.2

Limitations of Time

2.1.2, 2.2, 2.4, 3.2.2, 3.10, 3.11, 3.12.5, 3.15.1, 4.2.7, 5.2, ~~5.3~~, ~~5.3.1~~, 5.4.1, 6.2.4, 7.3, 7.4, 8.2, ~~9.2~~, ~~9.2.1~~, 9.3.1, 9.3.3, 9.4.1, 9.5, 9.6, ~~9.7~~, ~~9.7.1~~, 9.8, 9.9, 9.10, 11.1.3, 11.3.1.5, 11.3.6, 11.3.10, 12.2, 13.5, 13.7, 14, 15

Loss of Use Insurance

11.3.3

Material Suppliers

1.5, 3.12.1, 4.2.4, 4.2.6, 5.2.1, 9.3, 9.4.2, 9.6, 9.10.5

Materials, Hazardous

10.2.4, 10.3

Materials, Labor, Equipment and

1.1.3, 1.1.6, 1.5.1, 3.4.1, ~~3.5~~, ~~3.5.1~~, 3.8.2, 3.8.3, 3.12, ~~3.13~~, ~~3.13.1~~, 3.15.1, 4.2.6, 4.2.7, 5.2.1, 6.2.1, 7.3.7, 9.3.2, 9.3.3, 9.5.1.3, 9.10.2, 10.2.1.2, 10.2.4, 14.2.1.1, 14.2.1.2

Means, Methods, Techniques, Sequences and

Procedures of Construction

3.3.1, 3.12.10, 4.2.2, 4.2.7, 9.4.2

Mechanic's Lien

2.1.2, 15.2.8

Mediation

8.3.1, 10.3.5, 10.3.6, 15.2.1, 15.2.5, 15.2.6, 15.3, 15.4.1

Minor Changes in the Work

1.1.1, 3.12.8, 4.2.8, 7.1, 7.4

MISCELLANEOUS PROVISIONS

13

Modifications, Definition of

1.1.1

Modifications to the Contract

1.1.1, 1.1.2, 3.11, 4.1.2, 4.2.1, 5.2.3, 7, 8.3.1, 9.7, 9.7.1, 10.3.2, 11.3.1

Mutual Responsibility

6.2

Nonconforming Work, Acceptance of

9.6.6, 9.9.3, 12.3

Nonconforming Work, Rejection and Correction of

~~2.3~~, ~~2.4~~, ~~3.5~~, ~~2.3.1~~, ~~2.4.1~~, ~~3.5.1~~, 4.2.6, 6.2.4, 9.5.1, 9.8.2, 9.9.3, 9.10.4, 12.2.1

Notice

2.2.1, ~~2.3~~, ~~2.4~~, ~~2.3.1~~, ~~2.4.1~~, 3.2.4, 3.3.1, 3.7.2, 3.12.9, 5.2.1, ~~9.7~~, ~~9.7.1~~, 9.10, 10.2.2, 11.1.3, ~~11.4.6~~, 12.2.2.1, 13.3, 13.5.1, 13.5.2, 14.1, 14.2, 15.2.8, 15.4.1

Notice, Written

~~2.3~~, ~~2.4~~, ~~2.3.1~~, ~~2.4.1~~, 3.3.1, 3.9.2, 3.12.9, 3.12.10, 5.2.1, ~~9.7~~, ~~9.7.1~~, 9.10, 10.2.2, 10.3, 11.1.3, 11.3.6, 12.2.2.1, 13.3, 14, 15.2.8, 15.4.1

Notice of Claims

3.7.4, ~~4.5~~, 10.2.8, 15.1.2, 15.4

Notice of Testing and Inspections

13.5.1, 13.5.2

Observations, Contractor's

3.2, 3.7.4

Occupancy

2.2.2, 9.6.6, 9.8, 11.3.1.5

Orders, Written

1.1.1, 2.3, 3.9.2, 7, 8.2.2, 11.3.9, 12.1, 12.2.2.1, 13.5.2, 14.3.1

OWNER

2

Owner, Definition of

2.1.1

Owner, Information and Services Required of the

2.1.2, 2.2, 3.2.2, 3.12.10, 6.1.3, 6.1.4, 6.2.5, 9.3.2, 9.6.1, 9.6.4, 9.9.2, 9.10.3, 10.3.3, 11.2, 11.3, 13.5.1, 13.5.2, 14.1.1.4, 14.1.4, 15.1.3

Owner's Authority

1.5, 2.1.1, ~~2.3~~, ~~2.4~~, ~~2.3.1~~, ~~2.4.1~~, 3.4.2, 3.8.1, 3.12.10, 3.14.2, 4.1.2, 4.1.3, 4.2.4, 4.2.9, 5.2.1, 5.2.4, 5.4.1, 6.1, ~~6.3~~, ~~6.3.1~~, 7.2.1, 7.3.1, 8.2.2, 8.3.1, 9.3.1, 9.3.2, 9.5.1, 9.6.4, 9.9.1, 9.10.2, 10.3.2, 11.1.3, 11.3.3, 11.3.10, 12.2.2, ~~12.3~~, ~~12.3.1~~, 13.2.2, 14.3, 14.4, 15.2.7

Owner's Financial Capability

2.2.1, 13.2.2, 14.1.1.4

Owner's Liability Insurance

11.2

Owner's Loss of Use Insurance

11.3.3

Owner's Relationship with Subcontractors

1.1.2, 5.2, 5.3, 5.4, 9.6.4, 9.10.2, 14.2.2

Owner's Right to Carry Out the Work

2.4, 14.2.2

Owner's Right to Clean Up

6.3

Owner's Right to Perform Construction and to Award Separate Contracts

6.1

Owner's Right to Stop the Work

2.3

Owner's Right to Suspend the Work

14.3

Owner's Right to Terminate the Contract

14.2

init.

Ownership and Use of Drawings, Specifications and Other Instruments of Service

1.1.1, 1.1.6, 1.1.7, 1.5, 2.2.5, 3.2.2, ~~3.11, 3.17, 4.2.12, 5.3.11.1, 3.17.1, 4.2.12, 5.3.1~~

Partial Occupancy or Use

9.6.6, 9.9, 11.3.1.5

Patching, Cutting and

3.14, 6.2.5

Patents

3.17

Payment, Applications for

4.2.5, 7.3.9, ~~9.2, 9.2.1~~, 9.3, 9.4, 9.5, 9.6.3, ~~9.7, 9.7.1~~, 9.8.5, 9.10.1, 14.2.3, 14.2.4, 14.4.3

Payment, Certificates for

4.2.5, 4.2.9, 9.3.3, 9.4, 9.5, 9.6.1, 9.6.6, ~~9.7, 9.7.1~~, 9.10.1, 9.10.3, 13.7, 14.1.1.3, 14.2.4

Payment, Failure of

9.5.1.3, 9.7, 9.10.2, 13.6, 14.1.1.3, 14.2.1.2

Payment, Final

4.2.1, 4.2.9, 9.8.2, 9.10, 11.1.2, 11.1.3, 11.4.1, ~~12.3~~, 11.4.5, 12.3.1, 13.7, 14.2.4, 14.4.3

Payment Bond, Performance Bond and

7.3.7.4, 9.6.7, 9.10.3, ~~11.4.9, 11.4~~

Payments, Progress

9.3, 9.6, 9.8.5, 9.10.3, 13.6, 14.2.3, 15.1.3

PAYMENTS AND COMPLETION

9

Payments to Subcontractors

5.4.2, 9.5.1.3, 9.6.2, 9.6.3, 9.6.4, 9.6.7, ~~11.4.8~~, 14.2.1.2

PCB

10.3.1

Performance Bond and Payment Bond

7.3.7.4, 9.6.7, 9.10.3, ~~11.4.9, 11.4~~

Permits, Fees, Notices and Compliance with Laws

2.2.2, 3.7, 3.13, 7.3.7.4, 10.2.2

PERSONS AND PROPERTY, PROTECTION OF

10

Polychlorinated Biphenyl

10.3.1

Product Data, Definition of

3.12.2

Product Data and Samples, Shop Drawings

3.11, 3.12, 4.2.7

Progress and Completion

4.2.2, 8.2, 9.8, 9.9.1, 14.1.4, 15.1.3

Progress Payments

9.3, 9.6, 9.8.5, 9.10.3, 13.6, 14.2.3, 15.1.3

Project, Definition of the

1.1.4

Project Representatives

4.2.10

Property Insurance

10.2.5, 11.3

PROTECTION OF PERSONS AND PROPERTY

10

Regulations and Laws

1.5, 3.2.3, 3.6, 3.7, 3.12.10, 3.13, 4.1.1, 9.6.4, 9.9.1, 10.2.2, 11.1, 11.4, 13.1, 13.4, 13.5.1, 13.5.2, 13.6, 14, 15.2.8, 15.4

Rejection of Work

~~3.5, 3.5.1~~, 4.2.6, 12.2.1

Releases and Waivers of Liens

9.10.2

Representations

3.2.1, ~~3.5, 3.5.1~~, 3.12.6, 6.2.2, 8.2.1, 9.3.3, 9.4.2, 9.5.1, 9.8.2, 9.10.1

Representatives

2.1.1, 3.1.1, 3.9, 4.1.1, 4.2.1, 4.2.2, 4.2.10, 5.1.1, 5.1.2, 13.2.1

Responsibility for Those Performing the Work

3.3.2, 3.18, 4.2.3, ~~5.3, 5.3.1~~, 6.1.3, 6.2, 6.3, 9.5.1, 10

Retainage

9.3.1, 9.6.2, 9.8.5, 9.9.1, 9.10.2, 9.10.3

Review of Contract Documents and Field

Conditions by Contractor

3.2, 3.12.7, 6.1.3

Review of Contractor's Submittals by Owner and Architect

3.10.1, 3.10.2, 3.11, 3.12, 4.2, 5.2, 6.1.3, 9.2, 9.8.2

Review of Shop Drawings, Product Data and

Samples by Contractor

3.12

Rights and Remedies

1.1.2, 2.3, 2.4, ~~3.5, 3.5.1~~, 3.7.4, 3.15.2, 4.2.6, ~~4.5, 5.3~~, 5.4, 6.1, 6.3, 7.3.1, 8.3, 9.5.1, 9.7, 10.2.5, 10.3,

12.2.2, 12.2.4, 13.4, 14, 15.4

Royalties, Patents and Copyrights

3.17

Rules and Notices for Arbitration

15.4.1

Safety of Persons and Property

10.2, 10.4

Safety Precautions and Programs

3.3.1, 4.2.2, 4.2.7, ~~5.3, 5.3.1~~, 10.1, 10.2, 10.4

Samples, Definition of

3.12.3

Samples, Shop Drawings, Product Data and

3.11, 3.12, 4.2.7

Samples at the Site, Documents and

3.11

Schedule of Values

9.2, 9.3.1

Schedules, Construction

3.10, 3.12.1, 3.12.2, 6.1.3, 15.1.5.2

Separate Contracts and Contractors

1.1.4, 3.12.5, 3.14.2, 4.2.4, 4.2.7, 6, 8.3.1, ~~11.4.7~~, 12.1.2

Shop Drawings, Definition of

3.12.1

Shop Drawings, Product Data and Samples

3.11, 3.12, 4.2.7

Init.

Site, Use of
3.13, 6.1.1, 6.2.1
Site Inspections
 3.2.2, 3.3.3, 3.7.1, 3.7.4, 4.2, 9.4.2, 9.10.1, 13.5
Site Visits, Architect's
 3.7.4, 4.2.2, 4.2.9, 9.4.2, 9.5.1, 9.9.2, 9.10.1, 13.5
Special Inspections and Testing
 4.2.6, 12.2.1, 13.5
Specifications, Definition of the
1.1.6
Specifications, The
 1.1.1, 1.1.6, 1.2.2, 1.5, 3.11, 3.12.10, 3.17, 4.2.14
Statute of Limitations
 13.7, 15.4.1.1
Stopping the Work
 2.3, 9.7, 10.3, 14.1
Stored Materials
 6.2.1, 9.3.2, 10.2.1.2, ~~10.2.4~~ 10.2.4, 11.4.1.4
Subcontractor, Definition of
5.1.1
SUBCONTRACTORS
5
Subcontractors, Work by
 1.2.2, 3.3.2, 3.12.1, 4.2.3, 5.2.3, 5.3, 5.4, 9.3.1.2, 9.6.7
Subcontractual Relations
 5.3, 5.4, 9.3.1.2, 9.6, 9.10, 10.2.1, 11.4.7, 11.4.8,
 14.1, 14.2.1
Submittals
 3.10, 3.11, 3.12, 4.2.7, 5.2.1, 5.2.3, 7.3.7, 9.2, 9.3, 9.8, 9.9.1, 9.10.2, 9.10.3, 11.1.3
Submittal Schedule
 3.10.2, 3.12.5, 4.2.7
Subrogation, Waivers of
 6.1.1, 11.4.5, 11.3.7
Substantial Completion
 4.2.9, 8.1.1, 8.1.3, 8.2.3, 9.4.2, 9.8, 9.9.1, 9.10.3, 12.2, 13.7
Substantial Completion, Definition of
9.8.1
Substitution of Subcontractors
 5.2.3, 5.2.4
Substitution of Architect
 4.1.3
Substitutions of Materials
 3.4.2, ~~3.5, 3.5.1~~, 7.3.8
Sub-subcontractor, Definition of
5.1.2
Subsurface Conditions
 3.7.4
Successors and Assigns
13.2
Superintendent
 3.9, 10.2.6
Supervision and Construction Procedures
 1.2.2, 3.3, 3.4, 3.12.10, 4.2.2, 4.2.7, 6.1.3, 6.2.4, 7.1.3, 7.3.7, 8.2, 8.3.1, 9.4.2, 10, 12, 14, 15.1.3

Surety
 5.4.1.2, 9.8.5, 9.10.2, 9.10.3, 14.2.2, 15.2.7
Surety, Consent of
 9.10.2, 9.10.3
Surveys
 2.2.3
Suspension by the Owner for Convenience
14.3
Suspension of the Work
 5.4.2, 14.3
Suspension or Termination of the Contract
 5.4.1.1, 11.4.9, 14
Taxes
 3.6, 3.8.2.1, 7.3.7.4
Termination by the Contractor
14.1, 15.1.6
Termination by the Owner for Cause
 5.4.1.1, **14.2,** 15.1.6
Termination by the Owner for Convenience
14.4
Termination of the Architect
 4.1.3
Termination of the Contractor
 14.2.2
TERMINATION OR SUSPENSION OF THE CONTRACT
14
Tests and Inspections
 3.1.3, 3.3.3, 4.2.2, 4.2.6, 4.2.9, 9.4.2, 9.8.3, 9.9.2, 9.10.1, 10.3.2, ~~11.4.1,~~ 11.4.1.1, 12.2.1, **13.5**
TIME
8
Time, Delays and Extensions of
 3.2.4, 3.7.4, 5.2.3, 7.2.1, 7.3.1, ~~7.4,~~ 7.4.1, 8.3, 9.5.1, ~~9.7,~~ 10.3.2, ~~10.4,~~ 9.7.1, 10.3.2, 10.4.1, 14.3.2, 15.1.5, 15.2.5
Time Limits
 2.1.2, 2.2, 2.4, 3.2.2, 3.10, 3.11, 3.12.5, 3.15.1, 4.2, 4.4, 4.5, 5.2, 5.3, 5.4, 6.2.4, 7.3, 7.4, 8.2, 9.2, 9.3.1, 9.3.3, 9.4.1, 9.5, 9.6, 9.7, 9.8, 9.9, 9.10, 11.1.3, 11.4.1.5, 11.4.6, 11.4.10, 12.2, 13.5, 13.7, 14, 15.1.2, 15.4
Time Limits on Claims
 3.7.4, 10.2.8, **13.7,** 15.1.2
Title to Work
 9.3.2, 9.3.3
Transmission of Data in Digital Form
1.6
UNCOVERING AND CORRECTION OF WORK
12
Uncovering of Work
12.1
Unforeseen Conditions, Concealed or Unknown
 3.7.4, 8.3.1, 10.3
Unit Prices
 7.3.3.2, 7.3.4

Use of Documents

1.1.1, 1.5, 2.2.5, 3.12.6, 5.3

Use of Site

3.13, 6.1.1, 6.2.1

Values, Schedule of

9.2, 9.3.1

Waiver of Claims by the Architect

13.4.2

Waiver of Claims by the Contractor

9.10.5, 11.4.7, 13.4.2, 15.1.6

Waiver of Claims by the Owner

9.9.3, 9.10.3, 9.10.4, 11.4.3, 11.4.5, 11.4.7, 12.2.2.1, 13.4.2, 14.2.4, 15.1.6

Waiver of Consequential Damages

14.2.4, 15.1.6

Waiver of Liens

9.10.2, 9.10.4

Waivers of Subrogation

6.1.1, 11.4.5, 11.3.7

Warranty

3.5, 4.2.9, 9.3.3, 9.8.4, 9.9.1, 9.10.4, 12.2.2, 13.7

13.7.1

Weather Delays

15.1.5.2

Work, Definition of

1.1.3

Written Consent

1.5.2, 3.4.2, 3.7.4, 3.12.8, 3.14.2, 4.1.2, 9.3.2, 9.8.5, 9.9.1, 9.10.2, 9.10.3, 11.4.1, 13.2, 13.4.2, 15.4.4.2

Written Interpretations

4.2.11, 4.2.12

Written Notice

2.3, 2.4, 3.3.1, 3.9, 3.12.9, 3.12.10, 5.2.1, 8.2.2, 9.7, 9.10, 10.2.2, 10.3, 11.1.3, 11.4.6, 12.2.2, 12.2.4, 13.3, 14, 15.4.1

Written Orders

1.1.1, 2.3, 3.9, 7, 8.2.2, 11.4.9, 12.1, 12.2, 13.5.2, 14.3.1, 15.1.2

init.

ARTICLE 1 GENERAL PROVISIONS

§ 1.1 BASIC DEFINITIONS

§ 1.1.1 THE CONTRACT DOCUMENTS

The Contract Documents are enumerated in the Agreement between the Owner and Contractor (hereinafter the Agreement) and consist of the Agreement, Conditions of the Contract (General, Supplementary and other Conditions), Drawings, Specifications, Addenda issued prior to execution of the Contract, other documents listed in the Agreement and Modifications issued after execution of the Contract. A Modification is (1) a written amendment to the Contract signed by both parties, (2) a Change Order, (3) a Construction Change Directive or (4) a written order for a minor change in the Work issued by the Architect. Unless specifically enumerated in the Agreement, the Contract Documents do not include the advertisement or invitation to bid, Instructions to Bidders, sample forms, other information furnished by the Owner in anticipation of receiving bids or proposals, the Contractor's bid or proposal, or portions of Addenda relating to bidding requirements.

§ 1.1.2 THE CONTRACT

The Contract Documents form the Contract for Construction. The Contract represents the entire and integrated agreement between the parties hereto and supersedes prior negotiations, representations or agreements, either written or oral. The Contract may be amended or modified only by a Modification. The Contract Documents shall not be construed to create a contractual relationship of any kind (1) between the Contractor and the Architect or the Architect's consultants, (2) between the Owner and a Subcontractor or a Sub-subcontractor, (3) between the Owner and the Architect or the Architect's consultants or (4) between any persons or entities other than the Owner and the Contractor. The Architect shall, however, be entitled to performance and enforcement of obligations under the Contract intended to facilitate performance of the Architect's duties.

§ 1.1.3 THE WORK

The term "Work" means the construction and services required by the Contract Documents, whether completed or partially completed, and includes all other labor, materials, equipment and services provided or to be provided by the Contractor to fulfill the Contractor's obligations. The Work may constitute the whole or a part of the Project.

§ 1.1.4 THE PROJECT

The Project is the total construction of which the Work performed under the Contract Documents may be the whole or a part and which may include construction by the Owner and by separate contractors.

§ 1.1.5 THE DRAWINGS

The Drawings are the graphic and pictorial portions of the Contract Documents showing the design, location and dimensions of the Work, generally including plans, elevations, sections, details, schedules and diagrams.

§ 1.1.6 THE SPECIFICATIONS

The Specifications are that portion of the Contract Documents consisting of the written requirements for materials, equipment, systems, standards and workmanship for the Work, and performance of related services.

§ 1.1.7 INSTRUMENTS OF SERVICE

Instruments of Service are representations, in any medium of expression now known or later developed, of the tangible and intangible creative work performed by the Architect and the Architect's consultants under their respective professional services agreements. Instruments of Service may include, without limitation, studies, surveys, models, sketches, drawings, Project Manual, specifications, and other similar materials.

§ 1.1.8 INITIAL DECISION MAKER

The Initial Decision Maker is the person identified in the Agreement to render initial decisions on Claims in accordance with Section 15.2 and certify termination of the Agreement under Section 14.2.2.

§ 1.2 CORRELATION AND INTENT OF THE CONTRACT DOCUMENTS

§ 1.2.1 The intent of the Contract Documents is to include all items necessary for the proper execution and completion of the Work by the Contractor. The Contract Documents are complementary, and what is required by one shall be as binding as if required by all; performance by the Contractor shall be required only to the extent consistent with the Contract Documents and reasonably inferable from them as being necessary to produce the indicated results.

§ 1.2.2 Organization of the Specifications into divisions, sections and articles, and arrangement of Drawings shall not control the Contractor in dividing the Work among Subcontractors or in establishing the extent of Work to be performed by any trade.

§ 1.2.3 Unless otherwise stated in the Contract Documents, words that have well-known technical or construction industry meanings are used in the Contract Documents in accordance with such recognized meanings.

§ 1.3 CAPITALIZATION

Terms capitalized in these General Conditions include those that are (1) specifically defined, (2) the titles of numbered articles or (3) the titles of other documents published by the American Institute of Architects.

§ 1.4 INTERPRETATION

In the interest of brevity the Contract Documents frequently omit modifying words such as "all" and "any" and articles such as "the" and "an," but the fact that a modifier or an article is absent from one statement and appears in another is not intended to affect the interpretation of either statement.

§ 1.5 OWNERSHIP AND USE OF DRAWINGS, SPECIFICATIONS AND OTHER INSTRUMENTS OF SERVICE

§ 1.5.1 The Architect and the Architect's consultants shall be deemed the authors and owners of their respective Instruments of Service, including the Drawings and Specifications, and will retain all common law, statutory and other reserved rights, including copyrights. The Contractor, Subcontractors, Sub-subcontractors, and material or equipment suppliers shall not own or claim a copyright in the Instruments of Service. Submittal or distribution to meet official regulatory requirements or for other purposes in connection with this Project is not to be construed as publication in derogation of the Architect's or Architect's consultants' reserved rights.

§ 1.5.2 The Contractor, Subcontractors, Sub-subcontractors and material or equipment suppliers are authorized to use and reproduce the Instruments of Service provided to them solely and exclusively for execution of the Work. All copies made under this authorization shall bear the copyright notice, if any, shown on the Instruments of Service. The Contractor, Subcontractors, Sub-subcontractors, and material or equipment suppliers may not use the Instruments of Service on other projects or for additions to this Project outside the scope of the Work without the specific written consent of the Owner, Architect and the Architect's consultants.

§ 1.6 TRANSMISSION OF DATA IN DIGITAL FORM

If the parties intend to transmit Instruments of Service or any other information or documentation in digital form, they shall endeavor to establish necessary protocols governing such transmissions, unless otherwise already provided in the Agreement or the Contract Documents.

ARTICLE 2 OWNER

§ 2.1 GENERAL

§ 2.1.1 The Owner is the person or entity identified as such in the Agreement and is referred to throughout the Contract Documents as if singular in number. The Owner shall designate in writing a representative who shall have express authority to bind the Owner with respect to all matters requiring the Owner's approval or authorization. Except as otherwise provided in Section 4.2.1, the Architect does not have such authority. The term "Owner" means the Owner or the Owner's authorized representative.

~~§ 2.1.2 The Owner shall furnish to the Contractor within fifteen days after receipt of a written request, information necessary and relevant for the Contractor to evaluate, give notice of or enforce mechanic's lien rights. Such information shall include a correct statement of the record legal title to the property on which the Project is located, usually referred to as the site, and the Owner's interest therein.~~

§ 2.2 INFORMATION AND SERVICES REQUIRED OF THE OWNER

§ 2.2.1 Prior to commencement of the Work, the Contractor may request in writing that the Owner provide reasonable evidence that the Owner has made financial arrangements to fulfill the Owner's obligations under the Contract. Thereafter, the Contractor may only request such evidence if (1) the Owner fails to make payments to the Contractor as the Contract Documents require; (2) a change in the Work materially changes the Contract Sum; or (3) the Contractor identifies in writing a reasonable concern regarding the Owner's ability to make payment when due. The Owner shall furnish such evidence as a condition precedent to commencement or continuation of the Work or

the portion of the Work affected by a material change. After the Owner furnishes the evidence, the Owner shall not materially vary such financial arrangements without prior notice to the Contractor.

§ 2.2.2 Except for permits and fees that are the responsibility of the Contractor under the Contract Documents, including those required under Section 3.7.1, the Owner shall secure and pay for necessary approvals, easements, assessments and charges required for construction, use or occupancy of permanent structures or for permanent changes in existing facilities.

§ 2.2.3 The Owner shall furnish surveys describing physical characteristics, legal limitations and utility locations for the site of the Project, and a legal description of the site, site, as may be required. The Contractor shall be entitled to rely on the accuracy of information furnished by the Owner but shall exercise proper precautions relating to the safe performance of the Work.

§ 2.2.4 The Owner shall furnish information or services required of the Owner by the Contract Documents with reasonable promptness. The Owner shall also furnish any other information or services under the Owner's control and relevant to the Contractor's performance of the Work with reasonable promptness after receiving the Contractor's written request for such information or services.

§ 2.2.5 ~~Unless otherwise provided in the Contract Documents, the~~ The Owner shall furnish to the Contractor one ~~copy of the Contract Documents for purposes of making reproductions pursuant to Section 1.5.2 up to ten copies of the drawings and specifications as required for Contractor's execution of the Work. Any additional sets of documents that the contractor desires for construction of the Project will be issued to contractor at actual printing and handling costs.~~

§ 2.3 OWNER'S RIGHT TO STOP THE WORK

If the Contractor fails to correct Work that is not in accordance with the requirements of the Contract Documents as required by Section 12.2 or repeatedly fails to carry out Work in accordance with the Contract Documents, the Owner may issue a written order to the Contractor to stop the Work, or any portion thereof, until the cause for such order has been eliminated; however, the right of the Owner to stop the Work shall not give rise to a duty on the part of the Owner to exercise this right for the benefit of the Contractor or any other person or entity, except to the extent required by Section 6.1.3.

§ 2.4 OWNER'S RIGHT TO CARRY OUT THE WORK

If the Contractor defaults or neglects to carry out the Work in accordance with the Contract Documents and fails within a ten-day period after receipt of written notice from the Owner to commence and continue correction of such default or neglect with diligence and promptness, the Owner may, without prejudice to other remedies the Owner may have, correct such deficiencies. In such case an appropriate Change Order shall be issued deducting from payments then or thereafter due the Contractor the reasonable cost of correcting such deficiencies, including Owner's expenses and compensation for the Architect's additional services made necessary by such default, neglect or failure. Such action by the Owner and amounts charged to the Contractor are both subject to prior approval of the Architect. If payments then or thereafter due the Contractor are not sufficient to cover such amounts, the Contractor shall pay the difference to the Owner.

ARTICLE 3 CONTRACTOR

§ 3.1 GENERAL

§ 3.1.1 The Contractor is the person or entity identified as such in the Agreement and is referred to throughout the Contract Documents as if singular in number. The Contractor shall be lawfully licensed, if required in the jurisdiction where the Project is located. The Contractor shall designate in writing a representative who shall have express authority to bind the Contractor with respect to all matters under this Contract. The term "Contractor" means the Contractor or the Contractor's authorized representative.

§ 3.1.2 The Contractor shall perform the Work in accordance with the Contract Documents.

§ 3.1.3 The Contractor shall not be relieved of obligations to perform the Work in accordance with the Contract Documents either by activities or duties of the Architect in the Architect's administration of the Contract, or by tests, inspections or approvals required or performed by persons or entities other than the Contractor.

Init.

§ 3.2 REVIEW OF CONTRACT DOCUMENTS AND FIELD CONDITIONS BY CONTRACTOR

§ 3.2.1 Execution of the Contract by the Contractor is a representation that the Contractor has visited the site, become generally familiar with local conditions under which the Work is to be performed and correlated personal observations with requirements of the Contract Documents.

§ 3.2.2 Because the Contract Documents are complementary, the Contractor shall, before starting each portion of the Work, carefully study and compare the various Contract Documents relative to that portion of the Work, as well as the information furnished by the Owner pursuant to Section 2.2.3, shall take field measurements of any existing conditions related to that portion of the Work, and shall observe any conditions at the site affecting it. These obligations are for the purpose of facilitating coordination and construction by the Contractor and are not for the purpose of discovering errors, omissions, or inconsistencies in the Contract Documents; however, the Contractor shall promptly report to the Architect any errors, inconsistencies or omissions discovered by or made known to the Contractor as a request for information in such form as the Architect may require. It is recognized that the Contractor's review is made in the Contractor's capacity as a contractor and not as a licensed design professional, unless otherwise specifically provided in the Contract Documents.

§ 3.2.3 The Contractor is not required to ascertain that the Contract Documents are in accordance with applicable laws, statutes, ordinances, codes, rules and regulations, or lawful orders of public authorities, but the Contractor shall promptly report to the Architect any nonconformity discovered by or made known to the Contractor as a request for information in such form as the Architect may require.

§ 3.2.4 If the Contractor believes that additional cost or time is involved because of clarifications or instructions the Architect issues in response to the Contractor's notices or requests for information pursuant to Sections 3.2.2 or 3.2.3, the Contractor shall make Claims as provided in Article 15. If the Contractor fails to perform the obligations of Sections 3.2.2 or 3.2.3, the Contractor shall pay such costs and damages to the Owner as would have been avoided if the Contractor had performed such obligations. If the Contractor performs those obligations, the Contractor shall not be liable to the Owner or Architect for damages resulting from errors, inconsistencies or omissions in the Contract Documents, for differences between field measurements or conditions and the Contract Documents, or for nonconformities of the Contract Documents to applicable laws, statutes, ordinances, codes, rules and regulations, and lawful orders of public authorities.

§ 3.3 SUPERVISION AND CONSTRUCTION PROCEDURES

§ 3.3.1 The Contractor shall supervise and direct the Work, using the Contractor's best skill and attention. The Contractor shall be solely responsible for, and have control over, construction means, methods, techniques, sequences and procedures and for coordinating all portions of the Work under the Contract, unless the Contract Documents give other specific instructions concerning these matters. If the Contract Documents give specific instructions concerning construction means, methods, techniques, sequences or procedures, the Contractor shall evaluate the jobsite safety thereof and, except as stated below, shall be fully and solely responsible for the jobsite safety of such means, methods, techniques, sequences or procedures. If the Contractor determines that such means, methods, techniques, sequences or procedures may not be safe, the Contractor shall give timely written notice to the Owner and Architect and shall not proceed with that portion of the Work without further written instructions from the Architect. If the Contractor is then instructed to proceed with the required means, methods, techniques, sequences or procedures without acceptance of changes proposed by the Contractor, the Owner shall be solely responsible for any loss or damage arising solely from those Owner-required means, methods, techniques, sequences or procedures.

§ 3.3.2 The Contractor shall be responsible to the Owner for acts and omissions of the Contractor's employees, Subcontractors and their agents and employees, and other persons or entities performing portions of the Work for, or on behalf of, the Contractor or any of its Subcontractors.

§ 3.3.3 The Contractor shall be responsible for inspection of portions of Work already performed to determine that such portions are in proper condition to receive subsequent Work.

3.3.4 Three (3) days after the opening of the Bids, the Contractor shall furnish for written approval, an outline of the education, experience and character of the Contractor's project manager, superintendent and engineer. Any future substitution must have prior written approval of the Architect.

§ 3.4 LABOR AND MATERIALS

§ 3.4.1 Unless otherwise provided in the Contract Documents, the Contractor shall provide and pay for labor, materials, equipment, tools, construction equipment and machinery, water, heat, utilities, transportation, and other facilities and services necessary for proper execution and completion of the Work, whether temporary or permanent and whether or not incorporated or to be incorporated in the Work.

§ 3.4.2 Except in the case of minor changes in the Work authorized by the Architect in accordance with Sections 3.12.8 or 7.4, the Contractor may make substitutions only with the consent of the Owner, after evaluation by the Architect and in accordance with a Change Order or Construction Change Directive.

§ 3.4.3 The Contractor shall enforce strict discipline and good order among the Contractor's employees and other persons carrying out the Work. The Contractor shall not permit employment of unfit persons or persons not properly skilled in tasks assigned to ~~them~~them.

3.4.4 The Contractor's or his Subcontractor's supervisors and workmen engaged on special work or skilled Work in any supervisory position or trade shall be qualified and have had sufficient education, training and experience as a recognized professional or master mechanic in such Work to perform it properly and satisfactorily as prescribed in the Contract Documents.

3.4.5 Any project manager, superintendent, engineer, foreman or workman employed by the Contractor or by a subcontractor who, in the sole opinion of the Architect, does not perform his Work in a proper and skillful manner or becomes party to disrespectful, intemperate, disorderly, intoxicated, or dishonest behavior, or uses foul language, fights, commits criminal act(s) falsifies records and construction, covers-up faulty Work or materials, does not comprehend or follow instructions, does not get along with the Architect or Owner's representative, or is otherwise objectionable, shall, at the written request by the Architect, be discharged 24 hours by the Contractor or Subcontractor employing such project manager, superintendent, engineer, foreman or workman, and shall not be employed again or any portion of the Work without the written consent of the Architect.

3.4.6 Should the Contractor fail to remove such person or persons specified in Article 3.4.5 hereinabove or fail to furnish suitable and sufficient machinery, equipment, materials or qualified labor force for the proper execution of the Work, the Architect may withhold all payments which are or may become due the Contractor or may suspend the Work until such orders are complied with.

3.4.7 Contractor shall abide by provisions of Section 14-1 and Section 14.2, Code of the City of Mobile, originally adopted December 10, 1991. Prohibiting Discrimination in Employment by Contractors, Subcontractors and Vendors performing Work and providing materials and supplies for the City of Mobile. A copy of said Code is located in the City's Projects Architectural Engineering Department. Certification of compliance with this requirement shall be made for all persons involved in the Work by the signature of the General Contractor on the Bid Form (Section 00410).

§ 3.5 WARRANTY

The Contractor warrants to the Owner and Architect that materials and equipment furnished under the Contract will be of good quality and new unless the Contract Documents require or permit otherwise. The Contractor further warrants that the Work will conform to the requirements of the Contract Documents and will be free from defects, except for those inherent in the quality of the Work the Contract Documents require or permit. Work, materials, or equipment not conforming to these requirements may be considered defective. The Contractor's warranty excludes remedy for damage or defect caused by abuse, alterations to the Work not executed by the Contractor, improper or insufficient maintenance, improper operation, or normal wear and tear and normal usage. If required by the Architect, the Contractor shall furnish satisfactory evidence as to the kind and quality of materials and equipment.

§ 3.6 TAXES

The Contractor shall pay sales, consumer, use and similar taxes for the Work provided by the Contractor that are legally enacted when bids are received or negotiations concluded, whether or not yet effective or merely scheduled to go into effect.

§ 3.7 PERMITS, FEES, NOTICES AND COMPLIANCE WITH LAWS
PERMITS, FEES, NOTICES, AND COMPLIANCE WITH LAWS

§ 3.7.1 Unless otherwise provided in the Contract Documents, the Contractor shall secure ~~and pay for the building permit as well as for City of Mobile building permit without cost~~ and shall secure and pay for other permits, fees, licenses, and inspections by government agencies necessary for proper execution and completion of the Work that are customarily secured after execution of the Contract and legally required at the time bids are received or negotiations concluded.

3.7.1.1 The Contractor shall secure building and other permits customarily obtained from the City of Mobile at no cost.

§ 3.7.2 The Contractor shall comply with and give notices required by applicable laws, statutes, ordinances, codes, rules and regulations, and lawful orders of public authorities applicable to performance of the Work.

§ 3.7.3 If the Contractor performs Work knowing it to be contrary to applicable laws, statutes, ordinances, codes, rules and regulations, or lawful orders of public authorities, the Contractor shall assume appropriate responsibility for such Work and shall bear the costs attributable to correction.

§ 3.7.4 **Concealed or Unknown Conditions.** If the Contractor encounters conditions at the site that are (1) subsurface or otherwise concealed physical conditions that differ materially from those indicated in the Contract Documents or (2) unknown physical conditions of an unusual nature, that differ materially from those ordinarily found to exist and generally recognized as inherent in construction activities of the character provided for in the Contract Documents, the Contractor shall promptly provide notice to the Owner and the Architect before conditions are disturbed and in no event later than 21 days after first observance of the conditions. The Architect will promptly investigate such conditions and, if the Architect determines that they differ materially and cause an increase or decrease in the Contractor's cost of, or time required for, performance of any part of the Work, will recommend an equitable adjustment in the Contract Sum or Contract Time, or both. If the Architect determines that the conditions at the site are not materially different from those indicated in the Contract Documents and that no change in the terms of the Contract is justified, the Architect shall promptly notify the Owner and Contractor in writing, stating the reasons. If either party disputes the Architect's determination or recommendation, that party may proceed as provided in Article 15.

§ 3.7.5 If, in the course of the Work, the Contractor encounters human remains or recognizes the existence of burial markers, archaeological sites or wetlands not indicated in the Contract Documents, the Contractor shall immediately suspend any operations that would affect them and shall notify the Owner and Architect. Upon receipt of such notice, the Owner shall promptly take any action necessary to obtain governmental authorization required to resume the operations. The Contractor shall continue to suspend such operations until otherwise instructed by the Owner but shall continue with all other operations that do not affect those remains or features. Requests for adjustments in the Contract Sum and Contract Time arising from the existence of such remains or features may be made as provided in Article 15.

§ 3.8 ALLOWANCES

§ 3.8.1 The Contractor shall include in the Contract Sum all allowances stated in the Contract Documents. Items covered by allowances shall be supplied for such amounts and by such persons or entities as the Owner may direct, but the Contractor shall not be required to employ persons or entities to whom the Contractor has reasonable objection.

§ 3.8.2 Unless otherwise provided in the Contract Documents,

- .1 ~~Allowances~~ allowances shall cover the cost to the Contractor of materials and equipment delivered at the site and all required taxes, less applicable trade discounts;
- .2 Contractor's costs for unloading and handling at the site, labor, installation costs, overhead, profit and other expenses contemplated for stated allowance amounts shall be included in the Contract Sum but not in the allowances; and
- .3 ~~Whenever~~ whenever costs are more than or less than allowances, the Contract Sum shall be adjusted accordingly by Change Order. The amount of the Change Order shall reflect (1) the difference between actual costs and the allowances under Section 3.8.2.1 and (2) changes in Contractor's costs under Section 3.8.2.2.

init.

§ 3.8.3 Materials and equipment under an allowance shall be selected by the Owner with reasonable promptness.

§ 3.9 SUPERINTENDENT

§ 3.9.1 The Contractor shall employ a competent superintendent and necessary assistants who shall be in attendance at the Project site during performance of the Work. The superintendent shall represent the Contractor, and communications given to the superintendent shall be as binding as if given to the Contractor.

§ 3.9.2 The Contractor, as soon as practicable after award of the Contract, shall furnish in writing to the Owner through the Architect the name and qualifications of a proposed superintendent. The Architect may reply within 14 days to the Contractor in writing stating (1) whether the Owner or the Architect has reasonable objection to the proposed superintendent or (2) that the Architect requires additional time to review. Failure of the Architect to reply within the 14 day period shall constitute notice of no reasonable objection.

§ 3.9.3 The Contractor shall not employ a proposed superintendent to whom the Owner or Architect has made reasonable and timely objection. The Contractor shall not change the superintendent without the Owner's consent, which shall not unreasonably be withheld or delayed.

§ 3.10 CONTRACTOR'S CONSTRUCTION SCHEDULES

§ 3.10.1 The Contractor, ~~promptly within ten (10) business days~~ after being awarded the Contract, shall prepare and submit for the Owner's and Architect's information a Contractor's construction schedule for the Work. The schedule shall not exceed time limits current under the Contract Documents, shall be revised at appropriate intervals as required by the conditions of the Work and Project, shall be related to the entire Project to the extent required by the Contract Documents, and shall provide for expeditious and practicable execution of the Work.

§ 3.10.2 The Contractor shall prepare a submittal schedule, promptly after being awarded the Contract and thereafter as necessary to maintain a current submittal schedule, and shall submit the schedule(s) for the Architect's approval. The Architect's approval shall not unreasonably be delayed or withheld. The submittal schedule shall (1) be coordinated with the Contractor's construction schedule, and (2) allow the Architect reasonable time to review submittals. If the Contractor fails to submit a submittal schedule, the Contractor shall not be entitled to any increase in Contract Sum or extension of Contract Time based on the time required for review of submittals.

§ 3.10.3 The Contractor shall perform the Work in general accordance with the most recent schedules submitted to the Owner and Architect.

§ 3.11 DOCUMENTS AND SAMPLES AT THE SITE

The Contractor shall maintain at the site for the Owner one copy of the Drawings, Specifications, Addenda, Change Orders and other Modifications, in good order and marked currently to indicate field changes and selections made during construction, and one copy of approved Shop Drawings, Product Data, Samples and similar required submittals. These shall be available to the Architect and shall be delivered to the Architect for submittal to the Owner upon completion of the Work as a record of the Work as constructed.

§ 3.12 SHOP DRAWINGS, PRODUCT DATA AND SAMPLES

§ 3.12.1 Shop Drawings are drawings, diagrams, schedules and other data specially prepared for the Work by the Contractor or a Subcontractor, Sub-subcontractor, manufacturer, supplier or distributor to illustrate some portion of the Work.

§ 3.12.2 Product Data are illustrations, standard schedules, performance charts, instructions, brochures, diagrams and other information furnished by the Contractor to illustrate materials or equipment for some portion of the Work.

§ 3.12.3 Samples are physical examples that illustrate materials, equipment or workmanship and establish standards by which the Work will be judged.

§ 3.12.4 Shop Drawings, Product Data, Samples and similar submittals are not Contract Documents. Their purpose is to demonstrate the way by which the Contractor proposes to conform to the information given and the design concept expressed in the Contract Documents for those portions of the Work for which the Contract Documents require submittals. Review by the Architect is subject to the limitations of Section 4.2.7. Informational submittals

upon which the Architect is not expected to take responsive action may be so identified in the Contract Documents. Submittals that are not required by the Contract Documents may be returned by the Architect without action.

§ 3.12.5 The Contractor shall review for compliance with the Contract Documents, approve and submit to the Architect Shop Drawings, Product Data, Samples and similar submittals required by the Contract Documents in accordance with the submittal schedule approved by the Architect or, in the absence of an approved submittal schedule, with reasonable promptness and in such sequence as to cause no delay in the Work or in the activities of the Owner or of separate contractors. Submittals which are not marked as reviewed for compliance with the Contract Documents and approved by the Contractor may be returned by the Architect without action. Wherever Shop Drawings are required in these Specifications, Shop Drawings shall be submitted for approval before materials are fabricated. Drawings shall show complete details. The General Contractor shall check and approve them either in writing or by stamp before forwarding to the Architect. The Architect will mark copies "Approved" if correct; or, "Approved As Noted" if only minor corrections are necessary. If major corrections are necessary they will be noted on the Shop Drawings and they will be returned to the Contractor for correction and resubmission. Submit four (4) copies for Architect's and Owner's use plus the number of copies the contractor requires for his own use.

§ 3.12.6 By submitting Shop Drawings, Product Data, Samples and similar submittals, the Contractor represents to the Owner and Architect that the Contractor has (1) reviewed and approved them, (2) determined and verified materials, field measurements and field construction criteria related thereto, or will do so and (3) checked and coordinated the information contained within such submittals with the requirements of the Work and of the Contract Documents.

§ 3.12.7 The Contractor shall perform no portion of the Work for which the Contract Documents require submittal and review of Shop Drawings, Product Data, Samples or similar submittals until the respective submittal has been approved by the Architect.

§ 3.12.8 The Work shall be in accordance with approved submittals except that the Contractor shall not be relieved of responsibility for deviations from requirements of the Contract Documents by the Architect's approval of Shop Drawings, Product Data, Samples or similar submittals unless the Contractor has specifically informed the Architect in writing of such deviation at the time of submittal and (1) the Architect has given written approval to the specific deviation as a minor change in the Work, or (2) a Change Order or Construction Change Directive has been issued authorizing the deviation. The Contractor shall not be relieved of responsibility for errors or omissions in Shop Drawings, Product Data, Samples or similar submittals by the Architect's approval thereof.

§ 3.12.9 The Contractor shall direct specific attention, in writing or on resubmitted Shop Drawings, Product Data, Samples or similar submittals, to revisions other than those requested by the Architect on previous submittals. In the absence of such written notice, the Architect's approval of a resubmission shall not apply to such revisions.

§ 3.12.10 The Contractor shall not be required to provide professional services that constitute the practice of architecture or engineering unless such services are specifically required by the Contract Documents for a portion of the Work or unless the Contractor needs to provide such services in order to carry out the Contractor's responsibilities for construction means, methods, techniques, sequences and procedures. The Contractor shall not be required to provide professional services in violation of applicable law. If professional design services or certifications by a design professional related to systems, materials or equipment are specifically required of the Contractor by the Contract Documents, the Owner and the Architect will specify all performance and design criteria that such services must satisfy. The Contractor shall cause such services or certifications to be provided by a properly licensed design professional, whose signature and seal shall appear on all drawings, calculations, specifications, certifications, Shop Drawings and other submittals prepared by such professional. Shop Drawings and other submittals related to the Work designed or certified by such professional, if prepared by others, shall bear such professional's written approval when submitted to the Architect. The Owner and the Architect shall be entitled to rely upon the adequacy, accuracy and completeness of the services, certifications and approvals performed or provided by such design professionals, provided the Owner and Architect have specified to the Contractor all performance and design criteria that such services must satisfy. Pursuant to this Section 3.12.10, the Architect will review, approve or take other appropriate action on submittals only for the limited purpose of checking for conformance with information given and the design concept expressed in the Contract Documents. The Contractor

Int.

shall not be responsible for the adequacy of the performance and design criteria specified in the Contract Documents.

§ 3.13 USE OF SITE

The Contractor shall confine operations at the site to areas permitted by applicable laws, statutes, ordinances, codes, rules and regulations, and lawful orders of public authorities and the Contract Documents and shall not unreasonably encumber the site with materials or equipment.

§ 3.14 CUTTING AND PATCHING

§ 3.14.1 The Contractor shall be responsible for cutting, fitting or patching required to complete the Work or to make its parts fit together properly. All areas requiring cutting, fitting and patching shall be restored to the condition existing prior to the cutting, fitting and patching, unless otherwise required by the Contract Documents.

§ 3.14.2 The Contractor shall not damage or endanger a portion of the Work or fully or partially completed construction of the Owner or separate contractors by cutting, patching or otherwise altering such construction, or by excavation. The Contractor shall not cut or otherwise alter such construction by the Owner or a separate contractor except with written consent of the Owner and of such separate contractor; such consent shall not be unreasonably withheld. The Contractor shall not unreasonably withhold from the Owner or a separate contractor the Contractor's consent to cutting or otherwise altering the Work.

§ 3.15 CLEANING UP

§ 3.15.1 The Contractor shall keep the premises and surrounding area free from accumulation of waste materials or rubbish caused by operations under the Contract. At completion of the Work, the Contractor shall remove waste materials, rubbish, the Contractor's tools, construction equipment, machinery and surplus materials from and about the Project.

§ 3.15.2 If the Contractor fails to clean up as provided in the Contract Documents, the Owner may do so and Owner shall be entitled to reimbursement from the Contractor.

§ 3.16 ACCESS TO WORK

The Contractor shall provide the Owner and Architect access to the Work in preparation and progress wherever located.

§ 3.17 ROYALTIES, PATENTS AND COPYRIGHTS

The Contractor shall pay all royalties and license fees. The Contractor shall defend suits or claims for infringement of copyrights and patent rights and shall hold the Owner and Architect harmless from loss on account thereof, but shall not be responsible for such defense or loss when a particular design, process or product of a particular manufacturer or manufacturers is required by the Contract Documents, or where the copyright violations are contained in Drawings, Specifications or other documents prepared by the Owner or Architect. However, if the Contractor has reason to believe that the required design, process or product is an infringement of a copyright or a patent, the Contractor shall be responsible for such loss unless such information is promptly furnished to the Architect.

§ 3.18 INDEMNIFICATION

§ 3.18.1 To the fullest extent permitted by law the Contractor shall indemnify and hold harmless the Owner, Architect, Architect's consultants, and agents and employees of any of them from and against claims, damages, losses and expenses, including but not limited to attorneys' fees, arising out of or resulting from performance of the Work, provided that such claim, damage, loss or expense is attributable to bodily injury, sickness, disease or death, or to injury to or destruction of tangible property (other than the Work itself), but only to the extent caused by the negligent acts or omissions of the Contractor, a Subcontractor, anyone directly or indirectly employed by them or anyone for whose acts they may be liable, regardless of whether or not such claim, damage, loss or expense is caused in part by a party indemnified hereunder. Such obligation shall not be construed to negate, abridge, or reduce other rights or obligations of indemnity that which would otherwise exist as to a party or person described in this Section 3.18.

§ 3.18.2 In claims against any person or entity indemnified under this Section 3.18 by an employee of the Contractor, a Subcontractor, anyone directly or indirectly employed by them or anyone for whose acts they may be

init.

liable, the indemnification obligation under Section 3.18.1 shall not be limited by a limitation on amount or type of damages, compensation or benefits payable by or for the Contractor or a Subcontractor under workers' compensation acts, disability benefit acts or other employee benefit acts.

3.19 As applicable, the Contractor shall be responsible at the appropriate time during construction of the Project to have all permanent meters installed (electrical, water, gas, etc.) and all utilities connected prior to the time of Final Inspection. The Contractor shall pay all utilities costs until the Project is accepted by the City of Mobile.

ARTICLE 4 ARCHITECT

§ 4.1 GENERAL

§ 4.1.1 The Owner shall retain an architect lawfully licensed to practice architecture or an entity lawfully practicing architecture in the jurisdiction where the Project is located. That person or entity is identified as the Architect in the Agreement and is referred to throughout the Contract Documents as if singular in number. "Architect" may also designate the Licensed Designer of the Project and may be an Engineer or Landscape Architect.

§ 4.1.2 Duties, responsibilities and limitations of authority of the Architect as set forth in the Contract Documents shall not be restricted, modified or extended without written consent of the Owner, Contractor and Architect. Consent shall not be unreasonably withheld.

§ 4.1.3 If the employment of the Architect is terminated, the Owner shall employ a successor architect as to whom the Contractor has no reasonable objection and whose status under the Contract Documents shall be that of the Architect.

§ 4.2 ADMINISTRATION OF THE CONTRACT

§ 4.2.1 ~~The Architect will provide administration of the Contract as described in the Contract Documents and will be an Owner's representative during construction until the date the Architect issues the final Certificate for Payment: (1) during construction (2) until all conditions necessary for the final completion and payment have been fulfilled and (3) with the Owner's concurrence, from time to time during the one-year period for correction of Work described in Section 12.2. The Architect will have authority to act on behalf of the Owner only to the extent provided in the Contract Documents, unless otherwise modified in writing in accordance with other provisions of the Contract.~~

§ 4.2.2 The Architect will visit the site at intervals appropriate to the stage of construction, or as otherwise agreed with the Owner, to become generally familiar with the progress and quality of the portion of the Work completed, and to determine in general if the Work observed is being performed in a manner indicating that the Work, when fully completed, will be in accordance with the Contract Documents. However, the Architect will not be required to make exhaustive or continuous on-site inspections to check the quality or quantity of the Work. The Architect will not have control over, charge of, or responsibility for, the construction means, methods, techniques, sequences or procedures, or for the safety precautions and programs in connection with the Work, since these are solely the Contractor's rights and responsibilities under the Contract Documents, except as provided in Section 3.3.1.

§ 4.2.3 On the basis of the site visits, the Architect will keep the Owner reasonably informed about the progress and quality of the portion of the Work completed, and report to the Owner (1) known deviations from the Contract Documents and from the most recent construction schedule submitted by the Contractor, and (2) defects and deficiencies observed in the Work. The Architect will not be responsible for the Contractor's failure to perform the Work in accordance with the requirements of the Contract Documents. The Architect will not have control over or charge of and will not be responsible for acts or omissions of the Contractor, Subcontractors, or their agents or employees, or any other persons or entities performing portions of the Work.

§ 4.2.4 COMMUNICATIONS FACILITATING CONTRACT ADMINISTRATION

Except as otherwise provided in the Contract Documents or when direct communications have been specially authorized, the Owner and Contractor shall endeavor to communicate with each other through the Architect about matters arising out of or relating to the Contract. Communications by and with the Architect's consultants shall be through the Architect. Communications by and with Subcontractors and material suppliers shall be through the Contractor. Communications by and with separate contractors shall be through the Owner.

Int.

§ 4.2.5 Based on the Architect's evaluations of the Contractor's Applications for Payment, the Architect will review and certify the amounts due the Contractor and will issue Certificates for Payment in such amounts.

§ 4.2.6 The Architect has authority to reject Work that does not conform to the Contract Documents. Whenever the Architect considers it necessary or advisable, the Architect will have authority to require inspection or testing of the Work in accordance with Sections 13.5.2 and 13.5.3, whether or not such Work is fabricated, installed or completed. However, neither this authority of the Architect nor a decision made in good faith either to exercise or not to exercise such authority shall give rise to a duty or responsibility of the Architect to the Contractor, Subcontractors, material and equipment suppliers, their agents or employees, or other persons or entities performing portions of the Work.

§ 4.2.7 The Architect will review and approve, or take other appropriate action upon, the Contractor's submittals such as Shop Drawings, Product Data and Samples, but only for the limited purpose of checking for conformance with information given and the design concept expressed in the Contract Documents. The Architect's action will be taken in accordance with the submittal schedule approved by the Architect or, in the absence of an approved submittal schedule, with reasonable promptness while allowing sufficient time in the Architect's professional judgment to permit adequate review. Review of such submittals is not conducted for the purpose of determining the accuracy and completeness of other details such as dimensions and quantities, or for substantiating instructions for installation or performance of equipment or systems, all of which remain the responsibility of the Contractor as required by the Contract Documents. The Architect's review of the Contractor's submittals shall not relieve the Contractor of the obligations under Sections 3.3, 3.5 and 3.12. The Architect's review shall not constitute approval of safety precautions or, unless otherwise specifically stated by the Architect, of any construction means, methods, techniques, sequences or procedures. The Architect's approval of a specific item shall not indicate approval of an assembly of which the item is a component.

§ 4.2.8 The Architect will prepare Change Orders and Construction Change Directives, and may authorize minor changes in the Work as provided in Section 7.4. The Architect will investigate and make determinations and recommendations regarding concealed and unknown conditions as provided in Section 3.7.4.

§ 4.2.9 The Architect will conduct inspections to determine the date or dates of Substantial Completion and the date of final completion; issue Certificates of Substantial Completion pursuant to Section 9.8; receive and forward to the Owner, for the Owner's review and records, written warranties and related documents required by the Contract and assembled by the Contractor pursuant to Section 9.10; and issue a final Certificate for Payment pursuant to Section 9.10.

§ 4.2.10 If the Owner and Architect agree, the Architect will provide one or more project representatives to assist in carrying out the Architect's responsibilities at the site. The duties, responsibilities and limitations of authority of such project representatives shall be as set forth in an exhibit to be incorporated in the Contract Documents.

§ 4.2.11 The Architect will interpret and decide matters concerning performance under, and requirements of, the Contract Documents on written request of either the Owner or Contractor. The Architect's response to such requests will be made in writing within any time limits agreed upon or otherwise with reasonable promptness.

§ 4.2.12 Interpretations and decisions of the Architect will be consistent with the intent of, and reasonably inferable from, the Contract Documents and will be in writing or in the form of drawings. When making such interpretations and decisions, the Architect will endeavor to secure faithful performance by both Owner and Contractor, will not show partiality to either and will not be liable for results of interpretations or decisions rendered in good faith.

§ 4.2.13 The Architect's decisions on matters relating to aesthetic effect will be final if consistent with the intent expressed in the Contract Documents.

§ 4.2.14 The Architect will review and respond to requests for information about the Contract Documents. The Architect's response to such requests will be made in writing within any time limits agreed upon or otherwise with reasonable promptness. If appropriate, the Architect will prepare and issue supplemental Drawings and Specifications in response to the requests for information.

ARTICLE 5 SUBCONTRACTORS

§ 5.1 DEFINITIONS

§ 5.1.1 A Subcontractor is a person or entity who has a direct contract with the Contractor to perform a portion of the Work at the site. The term "Subcontractor" is referred to throughout the Contract Documents as if singular in number and means a Subcontractor or an authorized representative of the Subcontractor. The term "Subcontractor" does not include a separate contractor or subcontractors of a separate contractor.

§ 5.1.2 A Sub-subcontractor is a person or entity who has a direct or indirect contract with a Subcontractor to perform a portion of the Work at the site. The term "Sub-subcontractor" is referred to throughout the Contract Documents as if singular in number and means a Sub-subcontractor or an authorized representative of the Sub-subcontractor.

§ 5.2 AWARD OF SUBCONTRACTS AND OTHER CONTRACTS FOR PORTIONS OF THE WORK

§ 5.2.1 ~~Unless otherwise stated in the Contract Documents or the bidding requirements, the Contractor, as soon as practicable after award of the Contract, The apparent low bidder, within (3) days after bids are opened shall furnish in writing to the Owner through the Architect the names of persons or entities (including those who are to furnish materials or equipment fabricated to a special design) proposed for each principal portion of the Work. The Architect may reply within 14 days to the Contractor in writing stating (1) whether the Owner or the Architect has reasonable objection to any such proposed person or entity or (2) that the Architect requires additional time for review. Failure of the Owner or Architect to reply within the 14-day 14 day period shall constitute notice of no reasonable objection.~~

§ 5.2.2 The Contractor shall not contract with a proposed person or entity to whom the Owner or Architect has made reasonable and timely objection. The Contractor shall not be required to contract with anyone to whom the Contractor has made reasonable objection.

§ 5.2.3 If the Owner or Architect has reasonable objection to a person or entity proposed by the Contractor, the Contractor shall propose another to whom the Owner or Architect has no reasonable objection. ~~If the proposed but rejected Subcontractor was reasonably capable of performing the Work, the Contract Sum and Contract Time shall be increased or decreased by the difference, if any, occasioned by such change, and an appropriate Change Order shall be issued before commencement of the substitute Subcontractor's Work. However, no increase in the Contract Sum or Contract Time shall be allowed for such change unless the Contractor has acted promptly and responsively in submitting names as required.~~

§ 5.2.4 The Contractor shall not substitute a Subcontractor, person or entity previously selected if the Owner or Architect makes reasonable objection to such substitution.

§ 5.3 SUBCONTRACTUAL RELATIONS

By appropriate agreement, written where legally required for validity, the Contractor shall require each Subcontractor, to the extent of the Work to be performed by the Subcontractor, to be bound to the Contractor by terms of the Contract Documents, and to assume toward the Contractor all the obligations and responsibilities, including the responsibility for safety of the Subcontractor's Work, which the Contractor, by these Documents, assumes toward the Owner and Architect. Each subcontract agreement shall preserve and protect the rights of the Owner and Architect under the Contract Documents with respect to the Work to be performed by the Subcontractor so that subcontracting thereof will not prejudice such rights, and shall allow to the Subcontractor, unless specifically provided otherwise in the subcontract agreement, the benefit of all rights, remedies and redress against the Contractor that the Contractor, by the Contract Documents, has against the Owner. Where appropriate, the Contractor shall require each Subcontractor to enter into similar agreements with Sub-subcontractors. The Contractor shall make available to each proposed Subcontractor, prior to the execution of the subcontract agreement, copies of the Contract Documents to which the Subcontractor will be bound, and, upon written request of the Subcontractor, identify to the Subcontractor terms and conditions of the proposed subcontract agreement that may be at variance with the Contract Documents. Subcontractors will similarly make copies of applicable portions of such documents available to their respective proposed Sub-subcontractors.

§ 5.4 CONTINGENT ASSIGNMENT OF SUBCONTRACTS

§ 5.4.1 Each subcontract agreement for a portion of the Work is assigned by the Contractor to the Owner, provided that

Init.

- .1 assignment is effective only after termination of the Contract by the Owner for cause pursuant to Section 14.2 and only for those subcontract agreements that the Owner accepts by notifying the Subcontractor and Contractor in writing; and
- .2 assignment is subject to the prior rights of the surety, if any, obligated under bond relating to the Contract.

When the Owner accepts the assignment of a subcontract agreement, the Owner assumes the Contractor's rights and obligations under the subcontract.

§ 5.4.2 Upon such assignment, if the Work has been suspended for more than 30 days, the Subcontractor's compensation shall ~~may~~ be equitably adjusted for increases in cost resulting from the suspension.

§ 5.4.3 Upon such assignment to the Owner under this Section 5.4, the Owner may further assign the subcontract to a successor contractor or other entity. ~~If the Owner assigns the subcontract to a successor contractor or other entity, the Owner shall nevertheless remain legally responsible for all of the successor contractor's obligations under the subcontract.~~

ARTICLE 6 CONSTRUCTION BY OWNER OR BY SEPARATE CONTRACTORS

§ 6.1 OWNER'S RIGHT TO PERFORM CONSTRUCTION AND TO AWARD SEPARATE CONTRACTS

§ 6.1.1 The Owner reserves the right to perform construction or operations related to the Project with the Owner's own forces, and to award separate contracts in connection with other portions of the Project or other construction or operations on the site under Conditions of the Contract identical or substantially similar to these including those portions related to insurance and waiver of subrogation. If the Contractor claims that delay or additional cost is involved because of such action by the Owner, the Contractor shall make such Claim as provided in Article 15.

§ 6.1.2 When separate contracts are awarded for different portions of the Project or other construction or operations on the site, the term "Contractor" in the Contract Documents in each case shall mean the Contractor who executes each separate Owner-Contractor Agreement.

§ 6.1.3 The Owner shall provide for coordination of the activities of the Owner's own forces and of each separate contractor with the Work of the Contractor, who shall cooperate with them. The Contractor shall participate with other separate contractors and the Owner in reviewing their construction schedules. The Contractor shall make any revisions to the construction schedule deemed necessary after a joint review and mutual agreement. The construction schedules shall then constitute the schedules to be used by the Contractor, separate contractors and the Owner until subsequently revised.

§ 6.1.4 Unless otherwise provided in the Contract Documents, when the Owner performs construction or operations related to the Project with the Owner's own forces, the Owner shall be deemed to be subject to the same obligations and to have the same rights that apply to the Contractor under the Conditions of the Contract, including, without excluding others, those stated in Article 3, this Article 6 and Articles 10, 11 and 12.

§ 6.2 MUTUAL RESPONSIBILITY

§ 6.2.1 The Contractor shall afford the Owner and separate contractors reasonable opportunity for introduction and storage of their materials and equipment and performance of their activities, and shall connect and coordinate the Contractor's construction and operations with theirs as required by the Contract Documents.

§ 6.2.2 If part of the Contractor's Work depends for proper execution or results upon construction or operations by the Owner or a separate contractor, the Contractor shall, prior to proceeding with that portion of the Work, promptly report to the Architect apparent discrepancies or defects in such other construction that would render it unsuitable for such proper execution and results. Failure of the Contractor so to report shall constitute an acknowledgment that the Owner's or separate contractor's completed or partially completed construction is fit and proper to receive the Contractor's Work, except as to defects not then reasonably discoverable.

§ 6.2.3 The Contractor shall reimburse the Owner for costs the Owner incurs that are payable to a separate contractor because of the Contractor's delays, improperly timed activities or defective construction. The Owner shall be responsible to the Contractor for costs the Contractor incurs because of a separate contractor's delays, improperly timed activities, damage to the Work or defective construction.

init.

§ 6.2.4 The Contractor shall promptly remedy damage the Contractor wrongfully causes to completed or partially completed construction or to property of the Owner or separate contractors as provided in Section 10.2.5.

§ 6.2.5 The Owner and each separate contractor shall have the same responsibilities for cutting and patching as are described for the Contractor in Section 3.14.

§ 6.3 OWNER'S RIGHT TO CLEAN UP

If a dispute arises among the Contractor, separate contractors and the Owner as to the responsibility under their respective contracts for maintaining the premises and surrounding area free from waste materials and rubbish, the Owner may clean up and the Architect will allocate the cost among those responsible.

ARTICLE 7 CHANGES IN THE WORK

§ 7.1 GENERAL

§ 7.1.1 Changes in the Work may be accomplished after execution of the Contract, and without invalidating the Contract, by Change Order, Construction Change Directive or order for a minor change in the Work, subject to the limitations stated in this Article 7 and elsewhere in the Contract Documents. The total of all Change Orders on each contract shall not exceed ten percent (10%) of the contract price for each project and shall be subject to at least one of the following criteria:

- .1 Minor changes for a total monetary value less than required for competitive bidding under the State Competitive Bid Laws.
- .2 Changes for matters relatively minor and incidental to the original contract necessitated by unforeseen circumstances arising during the course of the Work.
- .3 Emergencies arising during the course of the Work on the Contract.
- .4 Changes or Alternates provided for in the original bidding where there is no difference in price on the Change Order from the original best bid on the Alternate.
- .5 Changes of relatively minor items not contemplated when the plans and specifications were prepared and the project was bid which are in the public interest.

§ 7.1.2 A Change Order shall be based upon agreement among the Owner, Contractor and Architect; a Construction Change Directive requires agreement by the Owner and Architect and may or may not be agreed to by the Contractor; an order for a minor change in the Work may be issued by the Architect alone.

§ 7.1.3 Changes in the Work shall be performed under applicable provisions of the Contract Documents, and the Contractor shall proceed promptly, unless otherwise provided in the Change Order, Construction Change Directive or order for a minor change in the Work.

§ 7.2 CHANGE ORDERS

§ 7.2.1 A Change Order is a written instrument prepared by the Architect and signed by the Owner, Contractor and Architect stating their agreement upon all of the following:

- .1 The change in the Work;
- .2 The amount of the adjustment, if any, in the Contract Sum; and
- .3 The extent of the adjustment, if any, in the Contract Time.
- .4 There shall be attached to each Change Order a signed statement from the Architect containing the following:
 - A. A statement of what the Change Order covers and who instituted the Change Order and why it is necessary or desired.
 - B. A statement setting forth the reasons for using the Change Order method rather than taking new competitive bids.
 - C. A statement that all prices have been reviewed and found reasonable, fair and equitable and recommending approval of the same.

§ 7.3 CONSTRUCTION CHANGE DIRECTIVES

§ 7.3.1 A Construction Change Directive is a written order prepared by the Architect and signed by the Owner and Architect, directing a change in the Work prior to agreement on adjustment, if any, in the Contract Sum or Contract Time, or both. The Owner may by Construction Change Directive, without invalidating the Contract, order changes

Int.

in the Work within the general scope of the Contract consisting of additions, deletions or other revisions, the Contract Sum and Contract Time being adjusted accordingly.

§ 7.3.2 A Construction Change Directive shall be used in the absence of total agreement on the terms of a Change Order.

§ 7.3.3 If the Construction Change Directive provides for an adjustment to the Contract Sum, the adjustment shall be based on one of the following methods:

- .1 Mutual acceptance of a lump sum properly itemized and supported by sufficient substantiating data to permit evaluation;
- .2 Unit prices stated in the Contract Documents or subsequently agreed upon;
- .3 Cost to be determined in a manner agreed upon by the parties and a mutually acceptable fixed or percentage fee; or
- .4 As provided in Section 7.3.7.

§ 7.3.4 If unit prices are stated in the Contract Documents or subsequently agreed upon, and if quantities originally contemplated are materially changed in a proposed Change Order or Construction Change Directive so that application of such unit prices to quantities of Work proposed will cause substantial inequity to the Owner or Contractor, the applicable unit prices shall may be equitably adjusted.

§ 7.3.5 Upon receipt of a Construction Change Directive, the Contractor shall promptly proceed with the change in the Work involved and advise the Architect of the Contractor's agreement or disagreement with the method, if any, provided in the Construction Change Directive for determining the proposed adjustment in the Contract Sum or Contract Time.

§ 7.3.6 A Construction Change Directive signed by the Contractor indicates the Contractor's agreement therewith, including adjustment in Contract Sum and Contract Time or the method for determining them. Such agreement shall be effective immediately and shall be recorded as a Change Order.

§ 7.3.7 If the Contractor does not respond promptly or disagrees with the method for adjustment in the Contract Sum, the Architect shall determine the method and the adjustment on the basis of reasonable expenditures and savings of those performing the Work attributable to the change, including, in case of an increase in the Contract Sum, ~~an amount for overhead and profit as set forth in the Agreement, or if no such amount is set forth in the Agreement, a reasonable amount~~ allowance of 10% mark-up on Subcontractor's direct cost (actual cost of Labor & Materials) and 15% mark-up on a Contractor's direct (actual cost of Labor & Materials). In such case, and also under Section 7.3.3.3, the Contractor shall keep and present, in such form as the Architect may prescribe, an itemized accounting together with appropriate supporting data. Unless otherwise provided in the Contract Documents, costs for the purposes of this Section 7.3.7 shall be limited to the following:

- .1 Costs of labor, including social security, old age and unemployment insurance, fringe benefits required by agreement or custom, and workers' compensation insurance;
- .2 Costs of materials, supplies and equipment, including cost of transportation, ~~whether incorporated or consumed; actually incorporated or consumed in the work;~~
- .3 Rental costs of machinery and equipment, exclusive of hand tools, whether rented ~~from~~ by the Contractor or others;
- .4 Costs of premiums for all bonds and insurance, permit fees, and sales, use or similar taxes related to the Work; and
- .5 Additional costs of supervision and field office personnel directly attributable to the change.

§ 7.3.8 The amount of credit to be allowed by the Contractor to the Owner for a deletion or change that results in a net decrease in the Contract Sum shall be actual net cost as confirmed by the Architect. When both additions and credits covering related Work or substitutions are involved in a change, the allowance for overhead and profit shall be figured on the basis of net increase, if any, with respect to that change.

§ 7.3.9 Pending final determination of the total cost of a Construction Change Directive to the Owner, the Contractor may request payment for Work completed under the Construction Change Directive in Applications for Payment. The Architect will make an interim determination for purposes of monthly certification for payment for those costs and certify for payment the amount that the Architect determines, in the Architect's professional judgment, to be

Init.

reasonably justified. The Architect's interim determination of cost shall adjust the Contract Sum on the same basis as a Change Order, subject to the right of either party to disagree and assert a Claim in accordance with Article 15.

§ 7.3.10 When the Owner and Contractor agree with a determination made by the Architect concerning the adjustments in the Contract Sum and Contract Time, or otherwise reach agreement upon the adjustments, such agreement shall be effective immediately and the Architect will prepare a Change Order. Change Orders may be issued for all or any part of a Construction Change Directive.

§ 7.4 MINOR CHANGES IN THE WORK

The Architect has authority to order minor changes in the Work not involving adjustment in the Contract Sum or extension of the Contract Time and not inconsistent with the intent of the Contract Documents. Such changes will be effected by written order signed by the Architect and shall be binding on the Owner and Contractor.

ARTICLE 8 TIME

§ 8.1 DEFINITIONS

§ 8.1.1 Unless otherwise provided, Contract Time is the period of time, including authorized adjustments, allotted in the Contract Documents for Substantial Completion of the Work.

§ 8.1.2 The date of commencement of the Work is the date established in the Agreement.

§ 8.1.3 The date of Substantial Completion is the date certified by the Architect in accordance with Section 9.8.

§ 8.1.4 The term "day" as used in the Contract Documents shall mean calendar day unless otherwise specifically defined.

§ 8.2 PROGRESS AND COMPLETION

§ 8.2.1 Time limits stated in the Contract Documents are of the essence of the Contract. By executing the Agreement the Contractor confirms that the Contract Time is a reasonable period for performing the Work.

§ 8.2.2 The Contractor shall not knowingly, except by agreement or instruction of the Owner in writing, prematurely commence operations on the site or elsewhere prior to the effective date of insurance required by Article 11 to be furnished by the Contractor and Owner. The date of commencement of the Work shall not be changed by the effective date of such insurance.

1. No Work shall commence and no materials ordered until the Owner issues the written Notice to Proceed.

2. The Work shall be commenced within ten (10) days of the date of a written Notice to Proceed.

§ 8.2.3 The Contractor shall proceed expeditiously with adequate forces and shall achieve Substantial Completion within the Contract Time.

§ 8.3 DELAYS AND EXTENSIONS OF TIME

§ 8.3.1 If the Contractor is delayed at any time in the commencement or progress of the Work by an act or neglect of the Owner or Architect, or of an employee of either, or of a separate contractor employed by the Owner; or by changes ordered in the Work; or by labor disputes, fire, unusual delay in deliveries, unavoidable casualties or other causes beyond the Contractor's control; or by delay authorized by the Owner pending mediation and arbitration; ~~Owner~~; or by other causes that the Architect determines may justify delay, then the Contract Time shall be extended by Change Order for such reasonable time as the Architect may determine.

§ 8.3.2 Claims relating to time shall be made in accordance with applicable provisions of Article 15.

§ 8.3.3 This Section 8.3 does not preclude recovery of damages for delay by either party under other provisions of the Contract Documents.

8.4 LIQUIDATED DAMAGES

8.4.1 Time is the essence of the Contract. Any delay in the completion of the Work as provided for in the Contract Documents will cause inconvenience to the public and loss and damage to the Owner in interest, and in additional administrative, architectural, inspection, and supervision charges.

Init.

Therefore, a time charge equal to \$250.00 per calendar day will be made against the Contractor for the entire period that any part of the Work remains uncompleted or any required closeouts documents are not acceptably submitted for more than 30 days after the time specified for the Substantial Completion of the Work, the amount of which shall be deducted by the Owner, and shall be retained by the Owner out of monies otherwise due the Contractor in the final payment, not as a penalty, but as liquidated damages sustained.

ARTICLE 9 PAYMENTS AND COMPLETION

§ 9.1 CONTRACT SUM

The Contract Sum is stated in the Agreement and, including authorized adjustments, is the total amount payable by the Owner to the Contractor for performance of the Work under the Contract Documents.

§ 9.2 SCHEDULE OF VALUES

Where the Contract is based on a stipulated sum or Guaranteed Maximum Price, the Contractor shall submit to the Architect, before the first Application for Payment, a schedule of values allocating the entire Contract Sum to the various portions of the Work and prepared in such form and supported by such data to substantiate its accuracy as the Architect may require. This schedule, unless objected to by the Architect, shall be used as a basis for reviewing the Contractor's Applications for Payment.

1. Unit Prices and Allowances, if stated in the Contract Documents, shall be identified within the Schedule of Values.

§ 9.3 APPLICATIONS FOR PAYMENT

~~§ 9.3.1 At least ten days before the date established for each progress payment, the Contractor shall submit to the Architect an itemized Application for Payment prepared in accordance with the on the first of each month for Work done through the 25th of the preceding month, four (4) original, itemized Applications for Payment for Work completed in accordance with the accepted schedule of values, if required under Section 9.2, 9.2., for completed portions of the Work. Such application shall be notarized, if required, notarized and supported by such data substantiating the Contractor's right to payment as the Owner or Architect may require, such as copies of requisitions from Subcontractors-subcontractors and material suppliers, and shall reflect retainage if provided for in the Contract Documents and documents as follows:~~

1. Until the final payment is made, the Owner shall pay ninety-seven and one half percent (97.5%) of the amount due the Contractor on account of progress payments (note: the 2-1/2% retainage is calculated by withholding the first 5% of the first 50% of the work completed); and

2. The Contractor shall provide documentation substantiating that test, inspections and approvals for portions of Work included in an Application for Payment and required by the Contract Documents, or by laws, ordinances, rules, regulations or orders of public authorities having jurisdiction were made at the appropriate time.

~~§ 9.3.1.1 As provided in Section 7.3.9, such Such applications may include requests for payment on account of changes in the Work that have been properly authorized by Construction Change Directives, or by interim determinations of the Architect, but not yet included in Change Orders. Work, which have been authorized and approved by properly executed Change Order(s).~~

~~§ 9.3.1.2 Applications for Payment shall not include requests for payment for portions of the Work for which the Contractor does not intend to pay a Subcontractor or material supplier, unless such Work has been performed by others whom the Contractor intends to pay. Such applications may include requests for payment on account of changes in the Work, which have been authorized and approve by properly executed Change Order(s).~~

§ 9.3.2 Unless otherwise provided in the Contract Documents, payments shall be made on account of materials and equipment delivered and suitably stored at the site for subsequent incorporation in the Work. If approved in advance by the Owner, payment may similarly be made for materials and equipment suitably stored off the site at a location agreed upon in writing. Payment for materials and equipment stored on or off the site shall be conditioned upon compliance by the Contractor with procedures satisfactory to the Owner to establish the Owner's title to such materials and equipment or otherwise protect the Owner's interest, and shall include the costs of applicable insurance, storage and transportation to the site for such materials and equipment stored off the site.

Int.

§ 9.3.3 The Contractor warrants that title to all Work covered by an Application for Payment will pass to the Owner no later than the time of payment. The Contractor further warrants that upon submittal of an Application for Payment all Work for which Certificates for Payment have been previously issued and payments received from the Owner shall, to the best of the Contractor's knowledge, information and belief, be free and clear of liens, claims, security interests or encumbrances in favor of the Contractor, Subcontractors, material suppliers, or other persons or entities making a claim by reason of having provided labor, materials and equipment relating to the Work.

§ 9.4 CERTIFICATES FOR PAYMENT

§ 9.4.1 The Architect will, within seven days after receipt of the Contractor's Application for Payment, either issue to the Owner a Certificate for Payment, with a copy to the Contractor, for such amount as the Architect determines is properly due, or notify the Contractor and Owner in writing of the Architect's reasons for withholding certification in whole or in part as provided in Section 9.5.1.

§ 9.4.2 The issuance of a Certificate for Payment will constitute a representation by the Architect to the Owner, based on the Architect's evaluation of the Work and the data comprising the Application for Payment, that, to the best of the Architect's knowledge, information and belief, the Work has progressed to the point indicated and that the quality of the Work is in accordance with the Contract Documents. The foregoing representations are subject to an evaluation of the Work for conformance with the Contract Documents upon Substantial Completion, to results of subsequent tests and inspections, to correction of minor deviations from the Contract Documents prior to completion and to specific qualifications expressed by the Architect. The issuance of a Certificate for Payment will further constitute a representation that the Contractor is entitled to payment in the amount certified. However, the issuance of a Certificate for Payment will not be a representation that the Architect has (1) made exhaustive or continuous on-site inspections to check the quality or quantity of the Work, (2) reviewed construction means, methods, techniques, sequences or procedures, (3) reviewed copies of requisitions received from Subcontractors and material suppliers and other data requested by the Owner to substantiate the Contractor's right to payment, or (4) made examination to ascertain how or for what purpose the Contractor has used money previously paid on account of the Contract Sum.

§ 9.5 DECISIONS TO WITHHOLD CERTIFICATION

§ 9.5.1 The Architect may withhold a Certificate for Payment in whole or in part, to the extent reasonably necessary to protect the Owner, if in the Architect's opinion the representations to the Owner required by Section 9.4.2 cannot be made. If the Architect is unable to certify payment in the amount of the Application, the Architect will notify the Contractor and Owner as provided in Section 9.4.1. If the Contractor and Architect cannot agree on a revised amount, the Architect will promptly issue a Certificate for Payment for the amount for which the Architect is able to make such representations to the Owner. The Architect may also withhold a Certificate for Payment or, because of subsequently discovered evidence, may nullify the whole or a part of a Certificate for Payment previously issued, to such extent as may be necessary in the Architect's opinion to protect the Owner from loss for which the Contractor is responsible, including loss resulting from acts and omissions described in Section 3.3.2, because of

- .1 defective Work not remedied;
- .2 third-party claims filed or reasonable evidence indicating probable filing of such claims unless security acceptable to the Owner is provided by the Contractor;
- .3 failure of the Contractor to make payments properly to Subcontractors or for labor, materials or equipment;
- .4 reasonable evidence that the Work cannot be completed for the unpaid balance of the Contract Sum;
- .5 damage to the Owner or a separate contractor;
- .6 reasonable evidence that the Work will not be completed within the Contract Time, and that the unpaid balance would not be adequate to cover actual or liquidated damages for the anticipated delay; or
- .7 repeated failure to carry out the Work in accordance with the Contract Documents.

§ 9.5.2 When the above reasons for withholding certification are removed, certification will be made for amounts previously withheld.

§ 9.5.3 If the Architect withholds certification for payment under Section 9.5.1.3, the Owner may, at its sole option, issue joint checks to the Contractor and to any Subcontractor or material or equipment suppliers to whom the Contractor failed to make payment for Work properly performed or material or equipment suitably delivered. If the

init.

Owner makes payments by joint check, the Owner shall notify the Architect and the Architect will reflect such payment on the next Certificate for Payment.

§ 9.6 PROGRESS PAYMENTS

§ 9.6.1 After the Architect has issued a Certificate for Payment, the Owner shall make payment in the manner and within the time provided in the Contract Documents, and shall so notify the Architect.

§ 9.6.2 The Contractor shall pay each Subcontractor no later than seven days after receipt of payment from the Owner the amount to which the Subcontractor is entitled, reflecting percentages actually retained from payments to the Contractor on account of the Subcontractor's portion of the Work. The Contractor shall, by appropriate agreement with each Subcontractor, require each Subcontractor to make payments to Sub-subcontractors in a similar manner.

§ 9.6.3 The Architect will, on request, furnish to a Subcontractor, if practicable, information regarding percentages of completion or amounts applied for by the Contractor and action taken thereon by the Architect and Owner on account of portions of the Work done by such Subcontractor.

§ 9.6.4 The Owner has the right to request written evidence from the Contractor that the Contractor has properly paid Subcontractors and material and equipment suppliers amounts paid by the Owner to the Contractor for subcontracted Work. If the Contractor fails to furnish such evidence within seven days, the Owner shall have the right to contact Subcontractors to ascertain whether they have been properly paid. Neither the Owner nor Architect shall have an obligation to pay or to see to the payment of money to a Subcontractor, except as may otherwise be required by law.

§ 9.6.5 Contractor payments to material and equipment suppliers shall be treated in a manner similar to that provided in Sections 9.6.2, 9.6.3 and 9.6.4.

§ 9.6.6 A Certificate for Payment, a progress payment, or partial or entire use or occupancy of the Project by the Owner shall not constitute acceptance of Work not in accordance with the Contract Documents.

§ 9.6.7 Unless the Contractor provides the Owner with a payment bond in the full penal sum of the Contract Sum, payments received by the Contractor for Work properly performed by Subcontractors and suppliers shall be held by the Contractor for those Subcontractors or suppliers who performed Work or furnished materials, or both, under contract with the Contractor for which payment was made by the Owner. Nothing contained herein shall require money to be placed in a separate account and not commingled with money of the Contractor, shall create any fiduciary liability or tort liability on the part of the Contractor for breach of trust or shall entitle any person or entity to an award of punitive damages against the Contractor for breach of the requirements of this provision.

§ 9.7 FAILURE OF PAYMENT

If the Architect does not issue a Certificate for Payment, through no fault of the Contractor, within seven days after receipt of the Contractor's Application for Payment, or if the Owner does not pay the Contractor within seven days after the date established in the Contract Documents the amount certified by the ~~Architect or awarded by binding dispute resolution, Architect~~, then the Contractor may, upon seven additional days' written notice to the Owner and Architect, stop the Work until payment of the amount owing has been received. The Contract Time ~~shall~~ may be extended appropriately and the Contract Sum ~~shall~~ may be increased by the amount of the Contractor's reasonable costs of shut-down, delay and start-up, plus interest as provided for in the Contract Documents.

§ 9.8 SUBSTANTIAL COMPLETION

§ 9.8.1 Substantial Completion is the stage in the progress of the Work when the Work or designated portion thereof is sufficiently complete in accordance with the Contract Documents so that the Owner can occupy or utilize the Work for its intended use.

§ 9.8.2 When the Contractor considers that the Work, or a portion thereof which the Owner agrees to accept separately, is substantially complete, the Contractor shall prepare and submit to the Architect a comprehensive list of items to be completed or corrected prior to final payment. Failure to include an item on such list does not alter the responsibility of the Contractor to complete all Work in accordance with the Contract Documents.

Init.

§ 9.8.3 Upon receipt of the Contractor's list, the Architect will make an inspection to determine whether the Work or designated portion thereof is substantially complete. If the Architect's inspection discloses any item, whether or not included on the Contractor's list, which is not sufficiently complete in accordance with the Contract Documents so that the Owner can occupy or utilize the Work or designated portion thereof for its intended use, the Contractor shall, before issuance of the Certificate of Substantial Completion, complete or correct such item upon notification by the Architect. In such case, the Contractor shall then submit a request for another inspection by the Architect to determine Substantial Completion.

§ 9.8.4 When the Work or designated portion thereof is substantially complete, the Architect will prepare a Certificate of Substantial Completion that shall establish the date of Substantial Completion, shall establish responsibilities of the Owner and Contractor for security, maintenance, heat, utilities, damage to the Work and insurance, and shall fix the time within which the Contractor shall finish all items on the list accompanying the Certificate. Warranties required by the Contract Documents shall commence on the date of Substantial Completion of the Work or designated portion thereof unless otherwise provided in the Certificate of Substantial Completion.

§ 9.8.5 The Certificate of Substantial Completion shall be submitted to the Owner and Contractor for their written acceptance of responsibilities assigned to them in such Certificate. Upon such acceptance and consent of surety, if any, the Owner shall make payment of retainage applying to such Work or designated portion thereof. ~~Such payment shall be adjusted for Work that is incomplete or not in accordance with the requirements of the Contract Documents.~~
Work.

§ 9.9 PARTIAL OCCUPANCY OR USE

§ 9.9.1 The Owner may occupy or use any completed or partially completed portion of the Work at any stage when such portion is designated by separate agreement with the Contractor, provided such occupancy or use is consented to by the insurer as required under Section 11.3.1.5 and authorized by public authorities having jurisdiction over the Project. Such partial occupancy or use may commence whether or not the portion is substantially complete, provided the Owner and Contractor have accepted in writing the responsibilities assigned to each of them for payments, retainage, if any, security, maintenance, heat, utilities, damage to the Work and insurance, and have agreed in writing concerning the period for correction of the Work and commencement of warranties required by the Contract Documents. When the Contractor considers a portion substantially complete, the Contractor shall prepare and submit a list to the Architect as provided under Section 9.8.2. Consent of the Contractor to partial occupancy or use shall not be unreasonably withheld. The stage of the progress of the Work shall be determined by written agreement between the Owner and Contractor or, if no agreement is reached, by decision of the Architect.

§ 9.9.2 Immediately prior to such partial occupancy or use, the Owner, Contractor and Architect shall jointly inspect the area to be occupied or portion of the Work to be used in order to determine and record the condition of the Work.

§ 9.9.3 Unless otherwise agreed upon, partial occupancy or use of a portion or portions of the Work shall not constitute acceptance of Work not complying with the requirements of the Contract Documents.

§ 9.10 FINAL COMPLETION AND FINAL PAYMENT

§ 9.10.1 Upon receipt of the Contractor's written notice that the Work is ready for final inspection and acceptance and upon receipt of a final Application for Payment, the Architect will promptly make such inspection and, when the Architect finds the Work acceptable under the Contract Documents and the Contract fully performed, the Architect will promptly issue a final Certificate for Payment stating that to the best of the Architect's knowledge, information and belief, and on the basis of the Architect's on-site visits and inspections, the Work has been completed in accordance with terms and conditions of the Contract Documents and that the entire balance found to be due the Contractor and noted in the final Certificate is due and payable. The Architect's final Certificate for Payment will constitute a further representation that conditions listed in Section 9.10.2 as precedent to the Contractor's being entitled to final payment have been fulfilled.

§ 9.10.2 Neither final payment nor any remaining retained percentage shall become due until the Contractor submits to the Architect (1) an affidavit that payrolls, bills for materials and equipment, and other indebtedness connected with the Work for which the Owner or the Owner's property might be responsible or encumbered (less amounts withheld by Owner) have been paid or otherwise satisfied, (2) a certificate evidencing that insurance required by the Contract Documents to remain in force after final payment is currently in effect and will not be canceled or allowed

to expire until at least 30 days' prior written notice has been given to the Owner, (3) a written statement that the Contractor knows of no substantial reason that the insurance will not be renewable to cover the period required by the Contract Documents, (4) consent of surety, if any, to final payment and (5), if required by the Owner, other data establishing payment or satisfaction of obligations, such as receipts, releases and waivers of liens, claims, security interests or encumbrances arising out of the Contract, to the extent and in such form as may be designated by the Owner. If a Subcontractor refuses to furnish a release or waiver required by the Owner, the Contractor may furnish a bond satisfactory to the Owner to indemnify the Owner against such lien. If such lien remains unsatisfied after payments are made, the Contractor shall refund to the Owner all money that the Owner may be compelled to pay in discharging such lien, including all costs and reasonable attorneys' fees payment. (5) contractors Affidavit of Release of Liens. (6) separate Releases or Waivers of Liens from Subcontractors and material and equipment suppliers (7) written warranty on Contractor's letterhead covering materials and labor for one year, and (8) the advertisement of completion. The Contractor shall provide proof of publication of Advertisement of completion in a local newspaper for four (4) consecutive weeks, as required in Title 39, Section 39-1-1, Subsection (f), of the Code of Alabama. The final 2.5% retained will not be paid until proof of publication is submitted and all written claims paid in full. This advertisement shall not begin until the City of Mobile has accepted the Project.

§ 9.10.3 If, after Substantial Completion of the Work, final completion thereof is materially delayed through no fault of the Contractor or by issuance of Change Orders affecting final completion, Contractor, and the Architect so confirms, the Owner shall, upon application by the Contractor and certification by the Architect, and without terminating the Contract, make payment of the balance due for that portion of the Work fully completed and accepted. If the remaining balance for Work not fully completed or corrected is less than retainage stipulated in the Contract Documents, and if bonds have been furnished, the written consent of surety to payment of the balance due for that portion of the Work fully completed and accepted shall be submitted by the Contractor to the Architect prior to certification of such payment. Such payment shall be made under terms and conditions governing final payment, except that it shall not constitute a waiver of claims.

§ 9.10.4 The making of final payment shall constitute a waiver of Claims by the Owner except those arising from

- .1 liens, Claims, security interests or encumbrances arising out of the Contract and unsettled;
- .2 failure of the Work to comply with the requirements of the Contract Documents; or
- .3 terms of special warranties required by the Contract Documents.

§ 9.10.5 Acceptance of final payment by the Contractor, a Subcontractor or material supplier shall constitute a waiver of claims by that payee except those previously made in writing and identified by that payee as unsettled at the time of final Application for Payment.

ARTICLE 10 PROTECTION OF PERSONS AND PROPERTY

§ 10.1 SAFETY PRECAUTIONS AND PROGRAMS

The Contractor shall be responsible for initiating, maintaining and supervising all safety precautions and programs in connection with the performance of the Contract.

§ 10.2 SAFETY OF PERSONS AND PROPERTY

§ 10.2.1 The Contractor shall comply with all Federal, State and Local law regarding safety including the requirements of the Occupational Safety and Health Act of 1970, Public Law #91-596, latest revision. Contractor shall take all other reasonable precautions for safety of, and shall provide reasonable protection to prevent damage, injury or loss to

- .1 employees on the Work and other persons who may be affected thereby;
- .2 the Work and materials and equipment to be incorporated therein, whether in storage on or off the site, under care, custody or control of the Contractor or the Contractor's Subcontractors or Sub-subcontractors; and
- .3 other property at the site or adjacent thereto, such as trees, shrubs, lawns, walks, pavements, roadways, structures and utilities not designated for removal, relocation or replacement in the course of construction.
- .4 The Contractor shall be responsible for damage done to buried cables and other utilities by its equipment and shall contact the appropriate offices prior to construction for information depth, etc., of utilities in the area.

§ 10.2.2 The Contractor shall comply with and give notices required by applicable laws, statutes, ordinances, codes, rules and regulations, and lawful orders of public authorities bearing on safety of persons or property or their protection from damage, injury or loss.

§ 10.2.3 The Contractor shall erect and maintain, as required by existing conditions and performance of the Contract, reasonable safeguards for safety and protection, including posting danger signs and other warnings against hazards, promulgating safety regulations and notifying owners and users of adjacent sites and utilities.

§ 10.2.4 When use or storage of explosives or other hazardous materials or equipment or unusual methods are necessary for execution of the Work, the Contractor shall exercise utmost care and carry on such activities under supervision of properly qualified personnel.

§ 10.2.5 The Contractor shall promptly remedy damage and loss ~~(other than damage or loss insured under property insurance required by the Contract Documents)~~ loss) to property referred to in Sections 10.2.1.2 and 10.2.1.3 caused in whole or in part by the Contractor, a Subcontractor, a Sub-subcontractor, or anyone directly or indirectly employed by any of them, or by anyone for whose acts they may be liable and for which the Contractor is responsible under Sections 10.2.1.2 and 10.2.1.3, except damage or loss attributable to acts or omissions of the Owner or Architect or anyone directly or indirectly employed by either of them, or by anyone for whose acts either of them may be liable, and not attributable to the fault or negligence of the Contractor. The foregoing obligations of the Contractor are in addition to the Contractor's obligations under Section 3.18.

§ 10.2.6 The Contractor shall designate a responsible member of the Contractor's organization at the site whose duty shall be the prevention of accidents. This person shall be the Contractor's superintendent unless otherwise designated by the Contractor in writing to the Owner and Architect.

§ 10.2.7 The Contractor shall not permit any part of the construction or site to be loaded so as to cause damage or create an unsafe condition.

§ 10.2.8 INJURY OR DAMAGE TO PERSON OR PROPERTY

If either party suffers injury or damage to person or property because of an act or omission of the other party, or of others for whose acts such party is legally responsible, written notice of such injury or damage, whether or not insured, shall be given to the other party within a reasonable time not exceeding 21 days after discovery. The notice shall provide sufficient detail to enable the other party to investigate the matter.

§ 10.3 HAZARDOUS MATERIALS

§ 10.3.1 The Contractor is responsible for compliance with any requirements included in the Contract Documents regarding hazardous materials. If the Contractor encounters a hazardous material or substance not addressed in the Contract Documents and if reasonable precautions will be inadequate to prevent foreseeable bodily injury or death to persons resulting from a material or substance, including but not limited to asbestos or polychlorinated biphenyl (PCB), encountered on the site by the Contractor, the Contractor shall, upon recognizing the condition, immediately stop Work in the affected area and report the condition to the Owner and Architect in writing.

§ 10.3.2 Upon receipt of the Contractor's written notice, the Owner shall obtain the services of a licensed laboratory to verify the presence or absence of the material or substance reported by the Contractor and, in the event such material or substance is found to be present, to cause it to be rendered harmless. Unless otherwise required by the Contract Documents, the Owner shall furnish in writing to the Contractor and Architect the names and qualifications of persons or entities who are to perform tests verifying the presence or absence of such material or substance or who are to perform the task of removal or safe containment of such material or substance. The Contractor and the Architect will promptly reply to the Owner in writing stating whether or not either has reasonable objection to the persons or entities proposed by the Owner. If either the Contractor or Architect has an objection to a person or entity proposed by the Owner, the Owner shall propose another to whom the Contractor and the Architect have no reasonable objection. When the material or substance has been rendered harmless, Work in the affected area shall resume upon written agreement of the Owner and Contractor. By Change Order, the Contract Time shall be extended appropriately and the Contract Sum shall be increased in the amount of the Contractor's reasonable additional costs of shut-down, delay and ~~start-up~~ start-up, except to the extent that any such delay is attributable to the Contractor's objection to the persons or entities whom Owner shall have furnished to perform the task of removal or safe containment of such material or substance.

Init.

~~§ 10.3.3 To the fullest extent permitted by law, the Owner shall indemnify and hold harmless the Contractor, Subcontractors, Architect, Architect's consultants and agents and employees of any of them from and against claims, damages, losses and expenses, including but not limited to attorneys' fees, arising out of or resulting from performance of the Work in the affected area if in fact the material or substance presents the risk of bodily injury or death as described in Section 10.3.1 and has not been rendered harmless, provided that such claim, damage, loss or expense is attributable to bodily injury, sickness, disease or death, or to injury to or destruction of tangible property (other than the Work itself), except to the extent that such damage, loss or expense is due to the fault or negligence of the party seeking indemnity.~~

~~§ 10.3.4 The Owner shall not be responsible under this Section 10.3 for materials or substances the Contractor brings to the site unless such materials or substances are required by the Contract Documents. The Owner shall be responsible for materials or substances required by the Contract Documents, except to the extent of the Contractor's fault or negligence in the use and handling of such materials or substances for materials or substances brought to the site by the Contractor regardless of whether such materials or substances were required by the Contract Documents.~~

§ 10.3.5 The Contractor shall indemnify the Owner for the cost and expense the Owner incurs (1) for remediation of a material or substance the Contractor brings to the site and negligently handles, or (2) where the Contractor fails to perform its obligations under Section 10.3.1, except to the extent that the cost and expense are due to the Owner's fault or negligence.

§ 10.3.6 If, without negligence or wantonness on the part of the Contractor, the Contractor is held liable by a government agency for the cost of remediation of a hazardous material or substance solely by reason of performing Work as required by the Contract Documents, the Owner shall indemnify ~~may reimburse~~ the Contractor for all reasonable cost and expense thereby incurred.

§ 10.4 EMERGENCIES

In an emergency affecting safety of persons or property, the Contractor shall act, at the Contractor's discretion, to prevent threatened damage, injury or loss. Additional compensation or extension of time claimed by the Contractor on account of an emergency shall ~~may~~ be determined only as provided in Article 15 and Article 7.

ARTICLE 11 INSURANCE AND BONDS

§ 11.1 CONTRACTOR'S LIABILITY INSURANCE

§ 11.1.1 The Contractor shall purchase from and maintain in a company or companies lawfully authorized to do business in the jurisdiction in which the Project is located such insurance as will protect the Contractor from claims set forth below which may arise out of or result from the Contractor's operations and completed operations under the Contract and for which the Contractor may be legally liable, whether such operations be by the Contractor or by a Subcontractor or by anyone directly or indirectly employed by any of them, or by anyone for whose acts any of them may be liable:

- .1 Claims under workers' compensation, disability benefit and other similar employee benefit acts that are applicable to the Work to be performed;
- .2 Claims for damages because of bodily injury, occupational sickness or disease, or death of the Contractor's employees;
- .3 Claims for damages because of bodily injury, sickness or disease, or death of any person other than the Contractor's employees;
- .4 Claims for damages insured by usual personal injury liability coverage;
- .5 Claims for damages, ~~other than to the Work itself,~~ because of injury to or destruction of tangible property, including loss of use resulting therefrom;
- .6 Claims for damages because of bodily injury, death of a person or property damage arising out of ownership, maintenance or use of a motor vehicle;
- .7 Claims for bodily injury or property damage arising out of completed operations; and
- .8 Claims involving contractual liability insurance applicable to the Contractor's obligations under Section 3.18.

The Contractor shall take out and maintain during the life of the Contract no less than the following amounts of insurance with the Owner named as an additional insured. Contractor shall submit a Certificate of Insurance and a supplemental Attachment for Certificate of Insurance 25-2 (7/90), AIA Document G715, Insurance companies listed as the "Companies Affording Coverage"

Init.

AIA Document A201™ - 2007. Copyright © 1911, 1915, 1918, 1925, 1937, 1951, 1958, 1961, 1963, 1966, 1970, 1978, 1987, 1997 and 2007 by The American Institute of Architects. All rights reserved. WARNING: This AIA® Document is protected by U.S. Copyright Law and International Treaties. Unauthorized reproduction or distribution of this AIA® Document, or any portion of it, may result in severe civil and criminal penalties, and will be prosecuted to the maximum extent possible under the law. This document was produced by AIA software at 15:13:02 on 07/19/2017 under Order No.7986168957_1 which expires on 08/01/2017, and is not for resale.

User Notes:

(1383216234)

shall be authorized by the Secretary of the State of Alabama. Insurance produced out of the State of Alabama must be signed or counter signed by a Resident Agent of Alabama, with the Resident Agent's name, address and telephone number typed or printed on the face of the Certificate of Insurance.

1. Workmen's Compensation and Employer's Liability Insurance: - Statutory-amount and coverage as required by law of place in which the Work is performed.

2. Employee's Liability Insurance shall be provided for limits of liability not less than:

- | | | |
|----|---------------------------|---------------------------|
| A. | Bodily Injury by Accident | \$1,000,000 each accident |
| B. | Bodily Injury by Disease | \$1,000,000 each employee |

3. The Contractor shall provide Broad Form (commonly termed Comprehensive) General Liability Insurance (including premises-product-completed operations) for limits of liability not less than:

- | | | |
|----|------------------------------------|--|
| A. | Bodily Injury | \$1,000,000 each person
\$1,000,000 each occurrence |
| B. | Property Damage | \$1,000,000 each occurrence: or |
| C. | Bodily Injury &
Property Damage | \$1,000,000 combined single limit |

4. Such comprehensive policy shall include the following:

- | | |
|----|---|
| A. | All liability of the Contractor, for the Contractor's Direct Operations. |
| B. | Subcontractor's Operations. |
| C. | Completed Operations Cover, thereby meaning any loss which shall occur after the contract has been completed, but which can be traced back to the Contract. |
| D. | Contractual Liability, meaning thereby, any risk assumed by the Contractor under Hold Harmless Agreements or any other assumption of liability, but specifically items 1.1, 1.8, 3G herein below |
| E. | Broad Form Property damage Coverage, including Completed Operations. |
| F. | Personal Injury Liability, with employee's exclusions removed. |
| G. | The Contractor shall indemnify and save harmless the Owner against all loss, cost, or damaged on account of injuries to persons or property occurring in the performance of the Contract, including all reasonable attorney's fees incurred by the Owner, on account thereof. |
| H. | Explosion and Collapse Hazard:
Included or <input checked="" type="checkbox"/> Not Applicable. |
| I. | Underground Hazard:
Included or <input checked="" type="checkbox"/> Not Applicable. |

5. The Contractor shall carry for himself and shall require that all Subcontractors and all Owners of Automobiles or trucks rented or hired on the contract carry until the Contract is completed, Comprehensive Automobile Liability Coverage for Bodily Injury and property Damage in amounts not less than the minimum amounts as indicated. The Contractor and Subcontractor shall also carry for themselves insurance for all non-owned and hired automobile at the limits of liability as indicated below:

- | | | |
|----|------------------------------------|--|
| A. | Bodily Injury | \$1,000,000 each person
\$1,000,000 each occurrence |
| B. | Property damage | \$1,000,000 each occurrence: or |
| C. | Bodily Injury &
Property damage | \$1,000,000 combined single limit |

6. Excess Liability: \$2,000,000 limit

init

7. Builder's Risk Coverage. The Contractor shall carry for the Owner, himself, and all Subcontractor's a Builder's Risk Policy to cover the full amount of the Contract during construction, fabrications or erection of any equipment.

8. A Surety authorized to do business in the State of Alabama shall furnish the required insurance.

9. The ACCORD™ Certificate must be signed or countersigned by a Licensed Resident Agent of the State of Alabama and the agent's name, address and telephone number must appear on the face of the certificate.

10. The Surety must have a minimum rating of A/Class VI as reported in the latest issue of Best's Key Rating Guide Property-Casualty, published by Alfred M. Best Company, Inc., if the bid price exceeds \$50,000.00

§ 11.1.2 The insurance required by Section 11.1.1 shall be written for not less than limits of liability specified in the Contract Documents or required by law, whichever coverage is greater. Coverages, whether written on an occurrence or claims-made basis, shall be maintained without interruption from the date of commencement of the Work until the date of final payment and termination of any coverage required to be maintained after final payment, and, with respect to the Contractor's completed operations coverage, until the expiration of the period for correction of Work or for such other period for maintenance of completed operations coverage as specified in the Contract Documents.

§ 11.1.3 Certificates of insurance acceptable to the Owner shall be filed with the Owner prior to commencement of the Work and thereafter upon renewal or replacement of each required policy of insurance. These certificates and the insurance policies required by this Section 11.1 shall contain a provision that coverages afforded under the policies will not be canceled or allowed to expire until at least 30 days' prior written notice has been given to the Owner. An additional certificate-evidencing continuation of liability coverage, including coverage for completed operations, shall be submitted with the final Application for Payment as required by Section 9.10.2 and thereafter upon renewal or replacement of such coverage until the expiration of the time required by Section 11.1.2. Information concerning reduction of coverage on account of revised limits or claims paid under the General Aggregate, or both, shall be furnished by the Contractor with reasonable promptness.

§ 11.1.4 The Contractor shall cause the commercial liability coverage required by the Contract Documents to include (1) the Owner, the Architect and the Architect's ~~consultants~~ Consultants as additional insureds for claims caused in whole or in part by the Contractor's negligent acts or omissions during the Contractor's operations; and (2) the Owner as an additional insured for claims caused in whole or in part by the Contractor's negligent acts or omissions during the Contractor's completed operations.

§ 11.2 OWNER'S LIABILITY INSURANCE

The Owner shall be responsible for purchasing and maintaining the Owner's usual liability insurance.

§ 11.3 PROPERTY INSURANCE

§ 11.3.1 ~~Unless otherwise provided, the Owner~~ The Contractor shall purchase and maintain, in a company or companies lawfully authorized to do business in the jurisdiction in which the Project is located, property insurance written on a builder's risk "all-risk" or equivalent policy form in the amount of the initial Contract Sum, plus value of subsequent Contract Modifications and cost of materials supplied or installed by others, comprising total value for the entire Project at the site on a replacement cost basis without optional deductibles, deductibles (See 11.1.1 Supplement Builder's Risk Coverage). Such property insurance shall be maintained, unless otherwise provided in the Contract Documents or otherwise agreed in writing by all persons and entities who are beneficiaries of such insurance, until final payment has been made as provided in Section 9.10 or until no person or entity other than the Owner has an insurable interest in the property required by this Section 11.3 to be covered, whichever is later. This insurance shall include interests of the Owner, the Contractor, Subcontractors and Sub-subcontractors in the Project.

§ 11.3.1.1 Property insurance shall be on an "all-risk" or equivalent policy form and shall include, without limitation, insurance against the perils of fire (with extended coverage) and physical loss or damage including, without duplication of coverage, theft, vandalism, malicious mischief, collapse, earthquake, flood, windstorm, falsework, testing and startup, temporary buildings and debris removal including demolition occasioned by enforcement of any applicable legal requirements, and shall cover reasonable compensation for Architect's and Contractor's services and expenses required as a result of such insured loss.

Init.

§ 11.3.1.2 If the Owner does not intend to purchase such property insurance required by the Contract and with all of the coverages in the amount described above, the Owner shall so inform the Contractor in writing prior to commencement of the Work. The Contractor may then effect insurance that will protect the interests of the Contractor, Subcontractors and Sub-subcontractors in the Work, and by appropriate Change Order the cost thereof shall be charged to the Owner. If the Contractor is damaged by the failure or neglect of the Owner to purchase or maintain insurance as described above, without so notifying the Contractor in writing, then the Owner shall bear all reasonable costs properly attributable thereto.

§ 11.3.1.3 If the property insurance requires deductibles, the ~~Owner-Contractor~~ shall pay costs not covered because of such deductibles.

§ 11.3.1.4 This property insurance shall cover portions of the Work stored off the site, and also portions of the Work in transit.

~~§ 11.3.1.5 Partial occupancy or use in accordance with Section 9.9 shall not commence until the insurance company or companies providing property insurance have consented to such partial occupancy or use by endorsement or otherwise. The Owner and the Contractor shall take reasonable steps to obtain consent of the insurance company or companies and shall, without mutual written consent, take no action with respect to partial occupancy or use that would cause cancellation, lapse or reduction of insurance.~~

~~§ 11.3.2 BOILER AND MACHINERY INSURANCE~~

~~The Owner shall purchase and maintain boiler and machinery insurance required by the Contract Documents or by law, which shall specifically cover such insured objects during installation and until final acceptance by the Owner; this insurance shall include interests of the Owner, Contractor, Subcontractors and Sub-subcontractors in the Work, and the Owner and Contractor shall be named insureds.~~

~~§ 11.3.3 LOSS OF USE INSURANCE~~

~~The Owner, at the Owner's option, may purchase and maintain such insurance as will insure the Owner against loss of use of the Owner's property due to fire or other hazards, however caused. The Owner waives all rights of action against the Contractor for loss of use of the Owner's property, including consequential losses due to fire or other hazards however caused.~~

~~§ 11.3.4 If the Contractor requests in writing that insurance for risks other than those described herein or other special causes of loss be included in the property insurance policy, the Owner shall, if possible, include such insurance, and the cost thereof shall be charged to the Contractor by appropriate Change Order.~~

~~§ 11.3.5 If during the Project construction period the Owner insures properties, real or personal or both, at or adjacent to the site by property insurance under policies separate from those insuring the Project, or if after final payment property insurance is to be provided on the completed Project through a policy or policies other than those insuring the Project during the construction period, the Owner shall waive all rights in accordance with the terms of Section 11.3.7 for damages caused by fire or other causes of loss covered by this separate property insurance. All separate policies shall provide this waiver of subrogation by endorsement or otherwise.~~

~~§ 11.3.6 Before an exposure to loss may occur, the Owner shall file with the Contractor a copy of each policy that includes insurance coverages required by this Section 11.3. Each policy shall contain all generally applicable~~

Int.

conditions, definitions, exclusions and endorsements related to this Project. Each policy shall contain a provision that the policy will not be canceled or allowed to expire, and that its limits will not be reduced, until at least 30 days' prior written notice has been given to the Contractor.

§ 11.3.7 WAIVERS OF SUBROGATION

The Owner and Contractor waive all rights against (1) each other and any of their subcontractors, sub-subcontractors, agents and employees, each of the other, and (2) the Architect, Architect's consultants, separate contractors described in Article 6, if any, and any of their subcontractors, sub-subcontractors, agents and employees, for damages caused by fire or other causes of loss to the extent covered by property insurance obtained pursuant to this Section 11.3 or other property insurance applicable to the Work, except such rights as they have to proceeds of such insurance held by the Owner as fiduciary. The Owner or Contractor, as appropriate, shall require of the Architect, Architect's consultants, separate contractors described in Article 6, if any, and the subcontractors, sub-subcontractors, agents and employees of any of them, by appropriate agreements, written where legally required for validity, similar waivers each in favor of other parties enumerated herein. The policies shall provide such waivers of subrogation by endorsement or otherwise. A waiver of subrogation shall be effective as to a person or entity even though that person or entity would otherwise have a duty of indemnification, contractual or otherwise, did not pay the insurance premium directly or indirectly, and whether or not the person or entity had an insurable interest in the property damaged.

§ 11.3.8 A loss insured under the Owner's property insurance shall be adjusted by the Owner as fiduciary and made payable to the Owner as fiduciary for the insureds, as their interests may appear, subject to requirements of any applicable mortgagee clause and of Section 11.3.10. The Contractor shall pay Subcontractors their just shares of insurance proceeds received by the Contractor, and by appropriate agreements, written where legally required for validity, shall require Subcontractors to make payments to their Sub-subcontractors in similar manner.

§ 11.3.9 If required in writing by a party in interest, the Owner as fiduciary shall, upon occurrence of an insured loss, give bond for proper performance of the Owner's duties. The cost of required bonds shall be charged against proceeds received as fiduciary. The Owner shall deposit in a separate account proceeds so received, which the Owner shall distribute in accordance with such agreement as the parties in interest may reach, or as determined in accordance with the method of binding dispute resolution selected in the Agreement between the Owner and Contractor. If after such loss no other special agreement is made and unless the Owner terminates the Contract for convenience, replacement of damaged property shall be performed by the Contractor after notification of a Change in the Work in accordance with Article 7.

§ 11.3.10 The Owner as fiduciary shall have power to adjust and settle a loss with insurers unless one of the parties in interest shall object in writing within five days after occurrence of loss to the Owner's exercise of this power; if such objection is made, the dispute shall be resolved in the manner selected by the Owner and Contractor as the method of binding dispute resolution in the Agreement. If the Owner and Contractor have selected arbitration as the method of binding dispute resolution, the Owner as fiduciary shall make settlement with insurers or, in the case of a dispute over distribution of insurance proceeds, in accordance with the directions of the arbitrators.

§ 11.4 PERFORMANCE BOND AND PAYMENT BOND

§ 11.4.1 The Owner shall have the right to require the Contractor to Contractor shall furnish bonds covering faithful performance of the Contract and payment of obligations arising thereunder as stipulated in bidding requirements or specifically required in the Contract Documents on the date of execution of the Contract thereunder.

§ 11.4.2 Upon the request of any person or entity appearing to be a potential beneficiary of bonds covering payment of obligations arising under the Contract, the Contractor shall promptly furnish a copy of the bonds or shall authorize a copy to be furnished.

11.4.3. The Labor and Material Payment Bond and Performance Bond shall each be for one hundred percent (100%) of the Contract price if the Contract Price is greater than \$10,000.00

1. Cost of the bonds shall be included in the bid.
2. Bonds shall be submitted with the executed agreement on provided form(s).

3. Power of Attorney is required for both bonds.
4. A Surety authorized to do business in the State of Alabama shall furnish both bonds.
5. A Surety licensed to do business in the State of Alabama must execute the bonds.
6. ~~Each bond must be signed or countersigned by a Resident Agent of the State of Alabama.~~
7. The Surety must have a minimum rating of A/Class VI as reported in the latest issue of Best's Key Rating Guide Property-Casualty, published by Alfred M. Best Company, Inc., if the bid price exceeds \$50,000.00.
8. The Surety company shall be required to execute AIA Document G-707, "Consent of Surety to Final Payment" prior to Final Payment being made to the Contractor.

ARTICLE 12 UNCOVERING AND CORRECTION OF WORK

§ 12.1 UNCOVERING OF WORK

§ 12.1.1 If a portion of the Work is covered contrary to the Architect's request or to requirements specifically expressed in the Contract Documents, it must, if requested in writing by the Architect, be uncovered for the Architect's examination and be replaced at the Contractor's expense without change in the Contract Time.

§ 12.1.2 If a portion of the Work has been covered that the Architect has not specifically requested to examine prior to its being covered, the Architect may request to see such Work and it shall be uncovered by the Contractor. If such Work is in accordance with the Contract Documents, costs of uncovering and replacement shall, by appropriate Change Order, be at the Owner's expense. If such Work is not in accordance with the Contract Documents, such costs and the cost of correction shall be at the Contractor's expense unless the condition was caused by the Owner or a separate contractor in which event the Owner shall be responsible for payment of such costs.

§ 12.2 CORRECTION OF WORK

§ 12.2.1 BEFORE OR AFTER SUBSTANTIAL COMPLETION

The Contractor shall promptly correct Work rejected by the Architect or failing to conform to the requirements of the Contract Documents, whether discovered before or after Substantial Completion and whether or not fabricated, installed or completed. Costs of correcting such rejected Work, including additional testing and inspections, the cost of uncovering and replacement, and compensation for the Architect's services and expenses made necessary thereby, shall be at the Contractor's expense.

§ 12.2.2 AFTER SUBSTANTIAL COMPLETION

§ 12.2.2.1 In addition to the Contractor's obligations under Section 3.5, if, within one year after the date of Substantial Completion of the Work or designated portion thereof or after the date for commencement of warranties established under Section 9.9.1, or by terms of an applicable special warranty required by the Contract Documents, any of the Work is found to be not in accordance with the requirements of the Contract Documents, the Contractor shall correct it promptly after receipt of written notice from the Owner to do so unless the Owner has previously given the Contractor a written acceptance of such condition. The Owner shall give such notice promptly after discovery of the condition. During the one-year period for correction of Work, if the Owner fails to notify the Contractor and give the Contractor an opportunity to make the correction, the Owner waives the rights to require correction by the Contractor and to make a claim for breach of warranty. If the Contractor fails to correct nonconforming Work within a reasonable time during that period after receipt of notice from the Owner or Architect, the Owner may correct it in accordance with Section 2.4.

§ 12.2.2.2 The one-year period for correction of Work shall be extended with respect to portions of Work first performed after Substantial Completion by the period of time between Substantial Completion and the actual completion of that portion of the Work.

§ 12.2.2.3 The one-year period for correction of Work shall not be extended by corrective Work performed by the Contractor pursuant to this Section 12.2.

§ 12.2.3 The Contractor shall remove from the site portions of the Work that are not in accordance with the requirements of the Contract Documents and are neither corrected by the Contractor nor accepted by the Owner.

Init.

§ 12.2.4 The Contractor shall bear the cost of correcting destroyed or damaged construction, whether completed or partially completed, of the Owner or separate contractors caused by the Contractor's correction or removal of Work that is not in accordance with the requirements of the Contract Documents.

§ 12.2.5 Nothing contained in this Section 12.2 shall be construed to establish a period of limitation with respect to other obligations the Contractor has under the Contract Documents. Establishment of the one-year period for correction of Work as described in Section 12.2.2 relates only to the specific obligation of the Contractor to correct the Work, and has no relationship to the time within which the obligation to comply with the Contract Documents may be sought to be enforced, nor to the time within which proceedings may be commenced to establish the Contractor's liability with respect to the Contractor's obligations other than specifically to correct the Work.

§ 12.3 ACCEPTANCE OF NONCONFORMING WORK

If the Owner prefers to accept Work that is not in accordance with the requirements of the Contract Documents, the Owner may do so instead of requiring its removal and correction, in which case the Contract Sum will be reduced as appropriate and equitable. Such adjustment shall be effected whether or not final payment has been made.

ARTICLE 13 MISCELLANEOUS PROVISIONS

§ 13.1 GOVERNING LAW

The Contract shall be governed by the law of the place where the Project is located except that, if the parties have selected arbitration as the method of binding dispute resolution, the Federal Arbitration Act shall govern Section 15.4.

State of Alabama.

§ 13.2 SUCCESSORS AND ASSIGNS

§ 13.2.1 The Owner and Contractor respectively bind themselves, their partners, successors, assigns and legal representatives to covenants, agreements and obligations contained in the Contract Documents. Except as provided in Section 13.2.2, neither party to the Contract shall assign the Contract as a whole without written consent of the other. If either party attempts to make such an assignment without such consent, that party shall nevertheless remain legally responsible for all obligations under the Contract.

§ 13.2.2 The Owner may, without consent of the Contractor, assign the Contract to a lender providing construction financing for the Project, if the lender assumes the Owner's rights and obligations under the Contract Documents. The Contractor shall execute all consents reasonably required to facilitate such assignment.

13.2.3 No assignment of the Contract shall be made without the written permission of Surety providing bonding and the City of Mobile.

§ 13.3 WRITTEN NOTICE

Written notice shall be deemed to have been duly served if delivered in person to the individual, to a member of the firm or entity, or to an officer of the corporation for which it was intended; or if delivered at, or sent by registered or certified mail or by courier service providing proof of delivery to, the last business address known to the party giving notice.

§ 13.4 RIGHTS AND REMEDIES

§ 13.4.1 Duties and obligations imposed by the Contract Documents and rights and remedies available thereunder shall be in addition to and not a limitation of duties, obligations, rights and remedies otherwise imposed or available by law.

§ 13.4.2 No action or failure to act by the Owner, Architect or Contractor shall constitute a waiver of a right or duty afforded them under the Contract, nor shall such action or failure to act constitute approval of or acquiescence in a breach there under, except as may be specifically agreed in writing.

§ 13.5 TESTS AND INSPECTIONS

§ 13.5.1 Tests, inspections and approvals of portions of the Work shall be made as required by the Contract Documents and by applicable laws, statutes, ordinances, codes, rules and regulations or lawful orders of public authorities. Unless otherwise provided, the Contractor shall make arrangements for such tests, inspections and approvals with an independent testing laboratory or entity acceptable to the Owner, or with the appropriate public

Init.

authority, and shall bear all related costs of tests, inspections and approvals. The Contractor shall give the Architect timely notice of when and where tests and inspections are to be made so that the Architect may be present for such procedures. The Owner shall bear costs of (1) tests, inspections or approvals that do not become requirements until after bids are received or negotiations concluded, and (2) tests, inspections or approvals where building codes or applicable laws or regulations prohibit the Owner from delegating their cost to the Contractor.

§ 13.5.2 If the Architect, Owner or public authorities having jurisdiction determine that portions of the Work require additional testing, inspection or approval not included under Section 13.5.1, the Architect will, upon written authorization from the Owner, instruct the Contractor to make arrangements for such additional testing, inspection or approval by an entity acceptable to the Owner, and the Contractor shall give timely notice to the Architect of when and where tests and inspections are to be made so that the Architect may be present for such procedures. Such costs, except as provided in Section 13.5.3, shall be at the Owner's expense.

§ 13.5.3 If such procedures for testing, inspection or approval under Sections 13.5.1 and 13.5.2 reveal failure of the portions of the Work to comply with requirements established by the Contract Documents, all costs made necessary by such failure including those of repeated procedures and compensation for the Architect's services and expenses shall be at the Contractor's expense.

§ 13.5.4 Required certificates of testing, inspection or approval shall, unless otherwise required by the Contract Documents, be secured by the Contractor and promptly delivered to the Architect.

§ 13.5.5 If the Architect is to observe tests, inspections or approvals required by the Contract Documents, the Architect will do so promptly and, where practicable, at the normal place of testing.

§ 13.5.6 Tests or inspections conducted pursuant to the Contract Documents shall be made promptly to avoid unreasonable delay in the Work.

13.5.7 Test, inspections or approvals made in addition to the Architects normal design and contract administration services caused by the Contractor shall be paid for by the Contractor. The normal service schedule is contained in Article 2.8.1 of AIA B102-2007 as amended by the Owner and is available to Contractor on request.

13.5.8 The Contractor must call the Urban Development Department of the City of Mobile for their inspections and approval at the times required by the Urban Development Department, as well as notify the Architect. Consulting Engineer, and/or Test Laboratory, for inspection and approval of sub-grade conditions, under slab and footing Conditions, vapor barrier placement, reinforcing steel placement, all structural connections, electrical, mechanical, etc. None of the above will be accepted that have been covered up before receiving approval of the Architect or his Consultant.

§ 13.6 INTEREST

~~Payments due and unpaid under the Contract Documents shall bear interest from the date payment is due at such rate as the parties may agree upon in writing or, in the absence thereof, at the legal rate prevailing from time to time at the place where the Project is located.~~

§ 13.7 TIME LIMITS ON CLAIMS

The Owner and Contractor shall commence all claims and causes of action, whether in contract, tort, breach of warranty or otherwise, against the other arising out of or related to the Contract in accordance with the requirements of the final dispute resolution method selected in the Agreement within the time period specified by applicable law, but in any case not more than 10 years after the date of Substantial Completion of the Work. The Owner and Contractor waive all claims and causes of action not commenced in accordance with this Section 13.7.

13.8 COMMENCEMENT OF STATUTORY LIMITATION PERIOD

13.8.1 As between the Owner and Contractor:

- I. Before Substantial Completion. As to acts or failures to act occurring prior to the relevant date of Substantial Completion, any applicable statute of limitations shall commence to run and any alleged cause of action shall be deemed to have accrued in any and all events not later than such date of Substantial Completion;

2. Between Substantial Completion and Final Payment. As to acts or failures to act occurring subsequent to the relevant date of Substantial Completion and prior to the final payment, any applicable statute of limitations shall commence to run and any alleged cause of action shall be deemed to have accrued in any and all event not later than the date of issuance of the final Certificate for Payment; and
3. After Final Payment. As to acts or failures to act occurring after the relevant date of the final Payment, any applicable statute of limitations shall commence to run and any alleged cause of action shall be deemed to have accrued in any and all events not later than the date of any act or failure to act by the Contractor pursuant to any Warranty provided under Section 3.5, the date of any correction of the Work or failure to correct the Work by the Contractor under Section 3.5, the date of any correction of the Work or failure to correct the Work by the Contractor under Section 12.2, or the date of actual commission of any other act or failure to perform any duty or obligation by the Contractor or Owner, whichever occurs last.

13.9 SUBSTITUTION OF MATERIALS AND EQUIPMENT

13.9.1 Whenever a material, article or piece of equipment is identified on the Drawings or in the Specifications by reference to manufacturer's or vendor's names, trade names, catalog numbers, or the like, it is so identified for the purpose of establishing a standard, and any material, article, or piece of equipment of other manufacturers or vendors which will perform adequately the duties imposed by the general design will be considered equally acceptable provided the material, article, or piece of equipment so proposed is, in the opinion of the Architect, of equal substance, appearance and function. It shall not be purchased or installed by the Contractor without the Architect's written approval.

ARTICLE 14 TERMINATION OR SUSPENSION OF THE CONTRACT

§ 14.1 TERMINATION BY THE CONTRACTOR

§ 14.1.1 The Contractor may terminate the Contract if the Work is stopped for a period of 30 consecutive days through no act or fault of the Contractor or a Subcontractor, Sub-subcontractor or their agents or employees or any other persons or entities performing portions of the Work under direct or indirect contract with the Contractor, for any of the following reasons:

1. Issuance of an order of a court or other public authority having jurisdiction that requires all Work to be stopped;
2. An act of government, such as a declaration of national emergency that requires all Work to be stopped;
3. Because the Architect has not issued a Certificate for Payment and has not notified the Contractor of the reason for withholding certification as provided in Section 9.4.1, or because the Owner has not made payment on a Certificate for Payment within the time stated in the Contract Documents; or
4. The Owner has failed to furnish to the Contractor promptly, upon the Contractor's request, reasonable evidence as required by Section 2.2.1.

§ 14.1.2 The Contractor may terminate the Contract if, through no act or fault of the Contractor or a Subcontractor, Sub-subcontractor or their agents or employees or any other persons or entities performing portions of the Work under direct or indirect contract with the Contractor, repeated suspensions, delays or interruptions of the entire Work by the Owner as described in Section 14.3 constitute in the aggregate more than 100 percent of the total number of days scheduled for completion, or 120 days in any 365-day period, whichever is less.

§ 14.1.3 If one of the reasons described in Section 14.1.1 or 14.1.2 exists, the Contractor may, upon seven days' written notice to the Owner and Architect, terminate the Contract and recover from the Owner payment for Work executed, including reasonable overhead and profit, costs incurred by reason of such termination, and damages executed.

§ 14.1.4 If the Work is stopped for a period of 60 consecutive days through no act or fault of the Contractor or a Subcontractor or their agents or employees or any other persons performing portions of the Work under contract with the Contractor because the Owner has repeatedly failed to fulfill the Owner's obligations under the Contract Documents with respect to matters important to the progress of the Work, the Contractor may, upon seven additional days' written notice to the Owner and the Architect, terminate the Contract and recover from the Owner as provided in Section 14.1.3.

§ 14.2 TERMINATION BY THE OWNER FOR CAUSE

§ 14.2.1 The Owner may terminate the Contract if the Contractor

- .1 repeatedly refuses or fails to supply enough properly skilled workers or proper materials;
- .2 fails to make payment to Subcontractors for materials or labor in accordance with the respective agreements between the Contractor and the Subcontractors;
- .3 repeatedly disregards applicable laws, statutes, ordinances, codes, rules and regulations, or lawful orders of a public authority; or
- .4 otherwise is guilty of substantial breach of a provision of the Contract Documents.

§ 14.2.2 When any of the above reasons exist, the Owner, upon certification by the Initial Decision Maker that sufficient cause exists to justify such action, may without prejudice to any other rights or remedies of the Owner and after giving the Contractor and the Contractor's surety, if any, seven days' written notice, terminate employment of the Contractor and may, subject to any prior rights of the surety:

- .1 Exclude the Contractor from the site and take possession of all materials, equipment, tools, and construction equipment and machinery thereon owned by the Contractor;
- .2 Accept assignment of subcontracts pursuant to Section 5.4; and
- .3 Finish the Work by whatever reasonable method the Owner may deem expedient. Upon written request of the Contractor, the Owner shall furnish to the Contractor a detailed accounting of the costs incurred by the Owner in finishing the Work.

§ 14.2.3 When the Owner terminates the Contract for one of the reasons stated in Section 14.2.1, the Contractor shall not be entitled to receive further payment until the Work is finished.

§ 14.2.4 If the unpaid balance of the Contract Sum exceeds costs of finishing the Work, including compensation for the Architect's services and expenses made necessary thereby, and other damages incurred by the Owner and not expressly waived, such excess shall be paid to the Contractor. If such costs and damages exceed the unpaid balance, the Contractor shall pay the difference to the Owner. The amount to be paid to the Contractor or Owner, as the case may be, shall be certified by the Initial Decision Maker, upon application, and this obligation for payment shall survive termination of the Contract.

§ 14.3 SUSPENSION BY THE OWNER FOR CONVENIENCE

§ 14.3.1 The Owner may, without cause, order the Contractor in writing to suspend, delay or interrupt the Work in whole or in part for such period of time as the Owner may determine.

§ 14.3.2 The Contract Sum and Contract Time shall ~~may~~ be adjusted for increases in the cost and time caused by suspension, delay or interruption as described in Section 14.3.1. Adjustment of the Contract Sum shall include profit. No adjustment shall be made to the extent

- .1 that performance is, was or would have been so suspended, delayed or interrupted by another cause for which the Contractor is responsible; or
- .2 that an equitable adjustment is made or denied under another provision of the Contract.

§ 14.4 TERMINATION BY THE OWNER FOR CONVENIENCE

§ 14.4.1 The Owner may, at any time, terminate the Contract for the Owner's convenience and without cause.

§ 14.4.2 Upon receipt of written notice from the Owner of such termination for the Owner's convenience, the Contractor shall

- .1 cease operations as directed by the Owner in the notice;
- .2 take actions necessary, or that the Owner may direct, for the protection and preservation of the Work; and
- .3 except for Work directed to be performed prior to the effective date of termination stated in the notice, terminate all existing subcontracts and purchase orders and enter into no further subcontracts and purchase orders.

§ 14.4.3 In case of such termination for the Owner's convenience, the Contractor shall be entitled to receive payment for Work executed, and costs incurred by reason of such termination, ~~along with reasonable overhead and profit on the Work not executed-termination.~~

Init.

ARTICLE 15 CLAIMS AND DISPUTES

§ 15.1 CLAIMS

§ 15.1.1 DEFINITION

A Claim is a demand or assertion by one of the parties seeking, as a matter of right, payment of money, or other relief with respect to the terms of the Contract. The term "Claim" also includes other disputes and matters in question between the Owner and Contractor arising out of or relating to the Contract. The responsibility to substantiate Claims shall rest with the party making the Claim.

§ 15.1.2 NOTICE OF CLAIMS

Claims by either the Owner or Contractor must be initiated by written notice to the other party and to the Initial Decision Maker with a copy sent to the Architect, if the Architect is not serving as the Initial Decision Maker. ~~Claims by either party must be initiated within 21 days after occurrence of the event giving rise to such Claim or within 21 days after the claimant first recognizes acting with due diligence, reasonable should have first recognized the condition giving rise to the Claim, whichever is later. Claims must be initiated by written notice to the Architect and the other party.~~

§ 15.1.3 CONTINUING CONTRACT PERFORMANCE

Pending final resolution of a Claim, except as otherwise agreed in writing or as provided in Section 9.7 and Article 14, the Contractor shall proceed diligently with performance of the Contract and the Owner shall continue to make payments in accordance with the Contract Documents. The Architect will prepare Change Orders and issue Certificates for Payment in accordance with the decisions of the Initial Decision Maker.

§ 15.1.4 CLAIMS FOR ADDITIONAL COST

If the Contractor wishes to make a Claim for an increase in the Contract Sum, written notice as provided herein shall be given before proceeding to execute the Work. Work giving rise to such claim. Prior notice is not required for Claims relating to an emergency endangering life or property arising under Section 10.4.

§ 15.1.5 CLAIMS FOR ADDITIONAL TIME

~~§ 15.1.5.1~~ If the Contractor wishes to make a Claim for an increase in the Contract Time, written notice as provided herein shall be given. The Contractor's Claim shall include an estimate of cost and of probable effect of delay on progress of the Work. In the case of a continuing delay, only one Claim is necessary.

~~§ 15.1.5.2~~ If adverse weather conditions are the basis for a Claim for additional time, such Claim shall be documented by data substantiating that weather conditions were abnormal for the period of time, could not have been reasonably anticipated and had an adverse effect on the scheduled construction.

§ 15.1.6 CLAIMS FOR CONSEQUENTIAL DAMAGES

The Contractor and Owner waive Claims against each other for consequential damages arising out of or relating to this Contract. This mutual waiver includes

- .1 damages incurred by the Owner for rental expenses, for losses of use, income, profit, financing, business and reputation, and for loss of management or employee productivity or of the services of such persons; and
- .2 damages incurred by the Contractor for principal office expenses including the compensation of personnel stationed there, for losses of financing, business and reputation, and for loss of profit except anticipated profit arising directly from the Work.

This mutual waiver is applicable, without limitation, to all consequential damages due to either party's termination in accordance with Article 14. Nothing contained in this Section 15.1.6 shall be deemed to preclude an award of liquidated damages, when applicable, in accordance with the requirements of the Contract Documents.

§ 15.2 INITIAL DECISION

§ 15.2.1 Claims, excluding those arising under Sections 10.3, 10.4, 11.3.9, and 11.3.10, shall be referred to the Initial Decision Maker for initial decision. The Architect will serve as the Initial Decision Maker, unless otherwise indicated in the Agreement. Except for those Claims excluded by this Section 15.2.1, an initial decision shall be required as a condition precedent to mediation of any Claim arising prior to the date final payment is due, unless 30 days have passed after the Claim has been referred to the Initial Decision Maker with no decision having been

Int.

rendered. Unless the Initial Decision Maker and all affected parties agree, the Initial Decision Maker will not decide disputes between the Contractor and persons or entities other than the Owner.

~~§ 15.2.2 The Initial Decision Maker-Architect will review Claims and within ten days of the receipt of a Claim take one or more of the following actions: (1) request additional supporting data from the claimant or a response with supporting data from the other party, (2) reject the Claim in whole or in part, (3) approve the Claim, (4) suggest a compromise, or (5) advise the parties that the Initial Decision Maker is unable to resolve the Claim if the Initial Decision Maker lacks sufficient information to evaluate the merits of the Claim or if the Initial Decision Maker concludes that, in the Initial Decision Maker's sole discretion, Architect reasonably concludes that, it would be inappropriate for the Initial Decision Maker to resolve the Claim.~~

§ 15.2.3 In evaluating Claims, the Initial Decision Maker may, but shall not be obligated to, consult with or seek information from either party or from persons with special knowledge or expertise who may assist the Initial Decision Maker in rendering a decision. The Initial Decision Maker may request the Owner to authorize retention of such persons at the Owner's expense.

§ 15.2.4 If the Initial Decision Maker requests a party to provide a response to a Claim or to furnish additional supporting data, such party shall respond, within ten days after receipt of such request, and shall either (1) provide a response on the requested supporting data, (2) advise the Initial Decision Maker when the response or supporting data will be furnished or (3) advise the Initial Decision Maker that no supporting data will be furnished. Upon receipt of the response or supporting data, if any, the Initial Decision Maker will either reject or approve the Claim in whole or in part.

~~§ 15.2.5 The Initial Decision Maker will render an initial decision approving or rejecting the Claim, or indicating that the Initial Decision Maker is unable to resolve the Claim. This initial decision shall (1) be in writing; (2) state the reasons therefor; therefore, and (3) notify the parties and the Architect, if the Architect is not serving as the Initial Decision Maker, of any change in the Contract Sum or Contract Time or both. The initial decision shall be final and binding on the parties but subject to mediation and, if the parties fail to resolve their dispute through mediation, to binding dispute resolution.~~

~~§ 15.2.6 Either party may file for mediation of an initial decision at any time, subject to the terms of Section 15.2.6.1.~~

~~§ 15.2.6.1 Either party may, within 30 days from the date of an initial decision, demand in writing that the other party file for mediation within 60 days of the initial decision. If such a demand is made and the party receiving the demand fails to file for mediation within the time required, then both parties waive their rights to mediate or pursue binding dispute resolution proceedings with respect to the initial decision.~~

§ 15.2.7 In the event of a Claim against the Contractor, the Owner may, but is not obligated to, notify the surety, if any, of the nature and amount of the Claim. If the Claim relates to a possibility of a Contractor's default, the Owner may, but is not obligated to, notify the surety and request the surety's assistance in resolving the controversy.

~~§ 15.2.8 If a Claim relates to or is the subject of a mechanic's lien, the party asserting such Claim may proceed in accordance with applicable law to comply with the lien notice or filing deadlines.~~

§ 15.3 MEDIATION

§ 15.3.1 Claims, disputes, or other matters in controversy arising out of or related to the Contract except those waived as provided for in Sections 9.10.4, 9.10.5, and 15.1.6 shall not be subject to mediation as a condition precedent to binding dispute resolution.

~~§ 15.3.2 The parties shall endeavor to resolve their Claims by mediation which, unless the parties mutually agree otherwise, shall be administered by the American Arbitration Association in accordance with its Construction Industry Mediation Procedures in effect on the date of the Agreement. A request for mediation shall be made in~~

Init.

writing, delivered to the other party to the Contract, and filed with the person or entity administering the mediation. The request may be made concurrently with the filing of binding dispute resolution proceedings but, in such event, mediation shall proceed in advance of binding dispute resolution proceedings, which shall be stayed pending mediation for a period of 60 days from the date of filing, unless stayed for a longer period by agreement of the parties or court order. If an arbitration is stayed pursuant to this Section 15.3.2, the parties may nonetheless proceed to the selection of the arbitrator(s) and agree upon a schedule for later proceedings.

§ 15.3.3 The parties shall share the mediator's fee and any filing fees equally. The mediation shall be held in the place where the Project is located, unless another location is mutually agreed upon. Agreements reached in mediation shall be enforceable as settlement agreements in any court having jurisdiction thereof.

§ 15.4 ARBITRATION

§ 15.4.1 If the parties have selected arbitration as the method for binding dispute resolution in the Agreement, any Claim subject to, but not resolved by, mediation shall be subject to arbitration which, unless the parties mutually agree otherwise, shall be administered by the American Arbitration Association in accordance with its Construction Industry Arbitration Rules in effect on the date of the Agreement. A demand for arbitration shall be made in writing, delivered to the other party to the Contract, and filed with the person or entity administering the arbitration. The party filing a notice of demand for arbitration must assert in the demand all Claims then known to that party on which arbitration is permitted to be demanded.

§ 15.4.1.1 A demand for arbitration shall be made no earlier than concurrently with the filing of a request for mediation, but in no event shall it be made after the date when the institution of legal or equitable proceedings based on the Claim would be barred by the applicable statute of limitations. For statute of limitations purposes, receipt of a written demand for arbitration by the person or entity administering the arbitration shall constitute the institution of legal or equitable proceedings based on the Claim.

§ 15.4.2 The award rendered by the arbitrator or arbitrators shall be final, and judgment may be entered upon it in accordance with applicable law in any court having jurisdiction thereof.

§ 15.4.3 The foregoing agreement to arbitrate and other agreements to arbitrate with an additional person or entity duly consented to by parties to the Agreement shall be specifically enforceable under applicable law in any court having jurisdiction thereof.

§ 15.4.4 CONSOLIDATION OR JOINDER

§ 15.4.4.1 Either party, at its sole discretion, may consolidate an arbitration conducted under this Agreement with any other arbitration to which it is a party provided that (1) the arbitration agreement governing the other arbitration permits consolidation, (2) the arbitrations to be consolidated substantially involve common questions of law or fact, and (3) the arbitrations employ materially similar procedural rules and methods for selecting arbitrator(s).

§ 15.4.4.2 Either party, at its sole discretion, may include by joinder persons or entities substantially involved in a common question of law or fact whose presence is required if complete relief is to be accorded in arbitration, provided that the party sought to be joined consents in writing to such joinder. Consent to arbitration involving an additional person or entity shall not constitute consent to arbitration of any claim, dispute or other matter in question not described in the written consent.

§ 15.4.4.3 The Owner and Contractor grant to any person or entity made a party to an arbitration conducted under this Section 15.4, whether by joinder or consolidation, the same rights of joinder and consolidation as the Owner and Contractor under this Agreement.

GENERAL RQUIREMENTS AND TECHNICAL SPECIFICATIONS

SECTION 011000 - SUMMARY

PART 1 - GENERAL

1.1 RELATED DOCUMENTS

- A. Drawings and general provisions of the Contract, including General and Supplementary Conditions and other Division 01 Specification Sections, apply to this Section.

1.2 SUMMARY

- A. This Section includes the following:
 - 1. Work covered by the Contract Documents.
 - 2. Type of the Contract.
 - 3. Contract Duration
 - 4. Specification formats and conventions.

1.3 WORK COVERED BY CONTRACT DOCUMENTS

- A. Project Identification: FD-072-21, Crichton Fire Station – Drive Repair.
 - 1. Project Location: 200 Davenport Ave., Mobile Alabama 36607
- B. Architect: Watermark Design Group, LLC., 2970 Cottage Hill Road, Suite 200, Mobile, AL. 36606
- C. The Work consists of the following:
 - 1. Removal of existing concrete apron and sidewalk.
 - 2. Assessment and remediation of base and sub-base material.
 - 3. Assessment of underground storm drainage system in the area of the work.
 - 4. Replace concrete apron and sidewalk.
 - 5. Repair trench drain.

1.4 TYPE OF CONTRACT

- A. Single Prime Contract.

1.5 CONTRACT DURATION

- A. One Hundred (100) Days from formal Notice To Proceed.

1.6 AGREEMENT

- A. Agreement between Owner and Contractor shall be AIA Document A-101 Standard Form of Agreement between Owner and Contractor where the basis of payment is a stipulated sum with supporting documents; AIA Document A201 General and Supplementary Conditions of the Contract for Construction.

1.7 USE OF PREMISES

- A. General Contractor will have limited access and use of the project site. Coordination with the facility Fire Department will be required. Precise work restrictions will be coordinated at the Pre-Construction Conference.
- B. During the Construction Period, the Crichton Fire Station will remain active. Coordination with Mobile Fire Rescue Department and Crichton Fire Station personnel will be required to insure there are no disruptions to the day-to-day operation of the facility.
- C. Personnel parking lot to remain accessible for duration of project.

1.8 WORK RESTRICTIONS

- A. On-Site Work Hours: the site is available 7 days a week, during daylight hours.
- B. Existing Utility Interruptions: Do not interrupt utilities serving facilities occupied by others unless permitted under the following conditions and then only after arranging to provide temporary utility services according to requirements indicated:
 - 1. Notify Owner not less than two days in advance of proposed utility interruptions.
 - 2. Do not proceed with utility interruptions without Owner's written permission.
- C. Nonsmoking Site: Smoking is not permitted anywhere on the property.

PART 2 - PRODUCTS (Not Used)

PART 3 - EXECUTION (Not Used)

END OF SECTION 011000

SECTION 01210 - ALLOWANCES

PART 1 - - GENERAL

1.1 RELATED DOCUMENTS

- A. Drawings and general provisions of the Contract, including General Conditions and Division 01 Specification Sections, apply to this Section.

1.2 SUMMARY

- A. Allowances will be utilized to:
 - 1. Defer selection of certain items until more information is available.
 - 2. Provide for discretionary installation of materials where exact and specific conditions cannot be determined in advance.
 - 3. Provide for the discretionary use of labor where tasks and time frames cannot be determined in advance.
- B. Include in Total Bid stipulated lump sum allowances amount as specified in this Section.

1.3 ALLOWANCE

- A. Include in the Total Base Quote a stipulated allowance(s) as indicated on the Quote Form for the use upon Owner's instruction. Upon Contractor inspection and Owner approval, any additional work that may be required, but not covered in the original Scope of Work (Base Bid), shall be added to the scope and cost charged against the Contingency Allowance. Contractor's cost for products, delivery, installation labor, insurance, payroll, bonding, equipment rental and overhead and profit will be included in the Allowances. Contractor's markups on allowances are limited to 10% for subcontractor's work and 15% for his own forces.
- B. Use of Contingency Allowance(s) shall be approved in writing by the Owner before any materials are ordered or work performed.
- C. Upon completion of the Work, any unused portion of the Allowances shall be credited back to the City of Mobile in the form of a Change Order.
- D. Contractor shall provide a detailed proposal of the work with overhead and profit broken out. Such proposals shall include proposals from subcontractors, also showing their detailed proposal with overhead and profit broken out.

1.4 SELECTION AND PURCHASE

- A. Advise the Project Manager when final selection and purchase of allowance item must be complete to avoid delay.

1.5 SUBMITTALS

- A. Request for Use of Allowance: Submit proposals for approval that detail and break out costs for contractors and subcontractor's markups.
- B. After Use of Allowance: Submit invoices to show quantity delivered to the site for each allowance.

PART 2 - PRODUCTS

Not used

PART 3 - EXECUTION

3.1 PREPARATION

- A. Coordinate materials and installation to assure that each item is fully integrated with related construction activities.

3.2 ALLOWANCE SCHEDULE

- A. Allowance No. 1:
 - 1. Contingency Allowance:
 - a. Include the sum of \$5,000.00 for unforeseen conditions.
 - b. The need to perform additional work and any associated increases in the Contract Amount shall be agreed upon by the City of Mobile and the Contractor prior to ordering of the materials or undertaking of the work.

END OF SECTION 012100

SECTION 01220 - UNIT PRICES

PART 1 - GENERAL

1.1 RELATED DOCUMENTS

- A. Drawings and general provisions of the Contract, including General and Supplementary Conditions and other Division 01 Specification Sections, apply to this Section.

1.2 SUMMARY

- A. Section includes:
 - 1. Administrative and procedural requirements for unit prices.
 - 2. Schedule of Unit Prices

1.3 DEFINITIONS

- A. Unit price is an amount incorporated in the Agreement which applicable for the duration of the Work as a price per unit of measurement for materials, equipment, services, or a portion of the Work, added to or deducted from the Contract Sum by appropriate modification if the scope of Work or estimated quantities of Work required by the Contract Documents are increased or decreased.

1.4 PROCEDURES

- A. Unit prices include all necessary material, plus cost for delivery, installation, insurance, applicable taxes, overhead, and profit.
- B. Measurement and Payment: See individual Specification Sections for work that requires establishment of unit prices. Methods of measurement and payment for unit prices are specified in those Sections.
- C. Owner reserves the right to reject Contractor's measurement of work-in-place that involves use of established unit prices and to have this work measured, at Owner's expense, by an independent surveyor acceptable to Contractor.
- D. List of Unit Prices: A schedule of unit prices is included in Part 3. Specification Sections referenced in the schedule contain requirements for materials described under each unit price.

PART 2 - PRODUCTS (Not Used)

PART 3 - PART 3 - EXECUTION

3.1 SCHEDULE OF UNIT PRICES

- A. Unit Price No. 1: EXCAVATION AND BACKFILL.
 - 1. Description: The removal and offsite disposal of unsuitable excavated materials and import, placement and compaction of structural fill material.
 - 2. Unit of Measurement: Cubic Yard.
- B. Unit Price No. 2: REMOVE AND REPLACE ASPHALT PAVING
 - 1. Description: Saw cutting and removal of in place asphalt paving, and installation of new asphalt paving.
 - 2. Unit of Measurement: Square Foot.

END OF SECTION

SECTION 014000 - QUALITY REQUIREMENTS

PART 1 - GENERAL

1.1 RELATED DOCUMENTS

- A. Drawings and general provisions of the Contract, including General and Supplementary Conditions and other Division 01 Specification Sections, apply to this Section.

1.2 SUMMARY

- A. This Section includes administrative and procedural requirements for quality assurance and quality control.
- B. Testing and inspecting services are required to verify compliance with requirements specified or indicated. These services do not relieve Contractor of responsibility for compliance with the Contract Document requirements.
 - 1. Specific quality-assurance and -control requirements for individual construction activities are specified in the Sections that specify those activities. Requirements in those Sections may also cover production of standard products.
 - 2. Specified tests, inspections, and related actions do not limit Contractor's other quality-assurance and -control procedures that facilitate compliance with the Contract Document requirements.
 - 3. Requirements for Contractor to provide quality-assurance and -control services required by Architect, Owner, or authorities having jurisdiction are not limited by provisions of this Section.
- C. Related Sections include the following:
 - 1. Divisions 02 through 49 Sections for specific test and inspection requirements.

1.3 DEFINITIONS

- A. Quality-Assurance Services: Activities, actions, and procedures performed before and during execution of the Work to guard against defects and deficiencies and substantiate that proposed construction will comply with requirements.
- B. Quality-Control Services: Tests, inspections, procedures, and related actions during and after execution of the Work to evaluate that actual products incorporated into the Work and completed construction comply with requirements. Services do not include contract enforcement activities performed by Architect.
- C. Product Testing: Tests and inspections that are performed by an NRTL, an NVLAP, or a testing agency qualified to conduct product testing and acceptable to authorities having jurisdiction, to establish product performance and compliance with industry standards.
- D. Source Quality-Control Testing: Tests and inspections that are performed at the source, i.e., plant, mill, factory, or shop.
- E. Field Quality-Control Testing: Tests and inspections that are performed on-site for installation of the Work and for completed Work.
- F. Testing Agency: An entity engaged to perform specific tests, inspections, or both. Testing laboratory shall mean the same as testing agency.

- G. Installer/Applicator/Erector: Contractor or another entity engaged by Contractor as an employee, Subcontractor, or Sub-subcontractor, to perform a particular construction operation, including installation, erection, application, and similar operations.
 - 1. Using a term such as "carpentry" does not imply that certain construction activities must be performed by accredited or unionized individuals of a corresponding generic name, such as "carpenter." It also does not imply that requirements specified apply exclusively to tradespeople of the corresponding generic name.
- H. Experienced: When used with an entity, "experienced" means having successfully completed a minimum of five previous projects similar in size and scope to this Project; being familiar with special requirements indicated; and having complied with requirements of authorities having jurisdiction.

1.4 CONFLICTING REQUIREMENTS

- A. General: If compliance with two or more standards is specified and the standards establish different or conflicting requirements for minimum quantities or quality levels, comply with the most stringent requirement. Refer uncertainties and requirements that are different, but apparently equal, to Architect for a decision before proceeding.
- B. Minimum Quantity or Quality Levels: The quantity or quality level shown or specified shall be the minimum provided or performed. The actual installation may comply exactly with the minimum quantity or quality specified, or it may exceed the minimum within reasonable limits. To comply with these requirements, indicated numeric values are minimum or maximum, as appropriate, for the context of requirements. Refer uncertainties to Architect for a decision before proceeding.

1.5 SUBMITTALS

- A. Qualification Data: For testing agencies specified in "Quality Assurance" Article to demonstrate their capabilities and experience. Include proof of qualifications in the form of a recent report on the inspection of the testing agency by a recognized authority.
- B. Reports: Prepare and submit certified written reports that include the following:
 - 1. Date of issue.
 - 2. Project title and number.
 - 3. Name, address, and telephone number of testing agency.
 - 4. Dates and locations of samples and tests or inspections.
 - 5. Names of individuals making tests and inspections.
 - 6. Description of the Work and test and inspection method.
 - 7. Identification of product and Specification Section.
 - 8. Complete test or inspection data.
 - 9. Test and inspection results and an interpretation of test results.
 - 10. Record of temperature and weather conditions at time of sample taking and testing and inspecting.
 - 11. Comments or professional opinion on whether tested or inspected Work complies with the Contract Document requirements.
 - 12. Name and signature of laboratory inspector.
 - 13. Recommendations on retesting and re-inspecting.
- C. Permits, Licenses, and Certificates: For Owner's records, submit copies of permits, licenses, certifications, inspection reports, releases, jurisdictional settlements, notices, receipts for fee

payments, judgments, correspondence, records, and similar documents, established for compliance with standards and regulations bearing on performance of the Work.

1.6 QUALITY ASSURANCE

- A. General: Qualifications paragraphs in this Article establish the minimum qualification levels required; individual Specification Sections specify additional requirements.
- B. Installer Qualifications: A firm or individual experienced in installing, erecting, or assembling work similar in material, design, and extent to that indicated for this Project, whose work has resulted in construction with a record of successful in-service performance.
- C. Manufacturer Qualifications: A firm experienced in manufacturing products or systems similar to those indicated for this Project and with a record of successful in-service performance, as well as sufficient production capacity to produce required units.
- D. Fabricator Qualifications: A firm experienced in producing products similar to those indicated for this Project and with a record of successful in-service performance, as well as sufficient production capacity to produce required units.
- E. Professional Engineer Qualifications: A professional engineer who is legally qualified to practice in jurisdiction where Project is located and who is experienced in providing engineering services of the kind indicated. Engineering services are defined as those performed for installations of the system, assembly, or product that are similar to those indicated for this Project in material, design, and extent.
- F. Testing Agency Qualifications: An NRTL, an NVLAP, or an independent agency with the experience and capability to conduct testing and inspecting indicated, as documented according to ASTM E 548; and with additional qualifications specified in individual Sections; and where required by authorities having jurisdiction, that is acceptable to authorities.
 - 1. NRTL: A nationally recognized testing laboratory according to 29 CFR 1910.7.
 - 2. NVLAP: A testing agency accredited according to NIST's National Voluntary Laboratory Accreditation Program.
- G. Factory-Authorized Service Representative Qualifications: An authorized representative of manufacturer who is trained and approved by manufacturer to inspect installation of manufacturer's products that are similar in material, design, and extent to those indicated for this Project.

1.7 QUALITY CONTROL

- A. Owner Responsibilities: Where quality-control services are indicated as Owner's responsibility, Owner will engage a qualified testing agency to perform these services.
 - 1. Owner will furnish Contractor with names, addresses, and telephone numbers of testing agencies engaged and a description of types of testing and inspecting they are engaged to perform.
 - 2. Costs for retesting and re-inspecting construction that replaces or is necessitated by work that failed to comply with the Contract Documents will be charged to Contractor, and the Contract Sum will be adjusted by Change Order.
- B. Tests and inspections not explicitly assigned to Owner are the Contractor's responsibility. Unless otherwise indicated, provide quality-control services specified and those required by authorities having jurisdiction. Perform quality-control services required of Contractor by authorities having jurisdiction, whether specified or not.

1. Where services are indicated as Contractor's responsibility, engage a qualified testing agency to perform these quality-control services.
 - a. Contractor shall not employ same entity engaged by Owner, unless agreed to in writing by Owner.
 2. Notify testing agencies at least 24 hours in advance of time when Work that requires testing or inspecting will be performed.
 3. Where quality-control services are indicated as Contractor's responsibility, submit a certified written report, in duplicate, of each quality-control service.
 4. Testing and inspecting requested by Contractor and not required by the Contract Documents are the Contractor's responsibility.
 5. Submit additional copies of each written report directly to authorities having jurisdiction, when they so direct.
- C. **Manufacturer's Field Services:** Where indicated, engage a factory-authorized service representative to inspect field-assembled components and equipment installation, including service connections. Report results in writing as specified in Division 01 Section "Submittal Procedures."
- D. **Retesting/Re-inspecting:** Regardless of whether original tests or inspections were Contractor's responsibility, provide quality-control services, including retesting and re-inspecting, for construction that replaced Work that failed to comply with the Contract Documents.
- E. **Testing Agency Responsibilities:** Cooperate with Architect and Contractor in performance of duties. Provide qualified personnel to perform required tests and inspections.
1. Notify Architect and Contractor promptly of irregularities or deficiencies observed in the Work during performance of its services.
 2. Determine the location from which test samples will be taken and in which in-situ tests are conducted.
 3. Conduct and interpret tests and inspections and state in each report whether tested and inspected work complies with or deviates from requirements.
 4. Submit a certified written report, in duplicate, of each test, inspection, and similar quality-control service through Contractor.
 5. Do not release, revoke, alter, or increase the Contract Document requirements or approve or accept any portion of the Work.
 6. Do not perform any duties of Contractor.
- F. **Associated Services:** Cooperate with agencies performing required tests, inspections, and similar quality-control services, and provide reasonable auxiliary services as requested. Notify agency sufficiently in advance of operations to permit assignment of personnel. Provide the following:
1. Access to the Work.
 2. Incidental labor and facilities necessary to facilitate tests and inspections.
 3. Adequate quantities of representative samples of materials that require testing and inspecting. Assist agency in obtaining samples.
 4. Facilities for storage and field curing of test samples.
 5. Delivery of samples to testing agencies.
 6. Preliminary design mix proposed for use for material mixes that require control by testing agency.
 7. Security and protection for samples and for testing and inspecting equipment at Project site.

- G. Coordination: Coordinate sequence of activities to accommodate required quality-assurance and -control services with a minimum of delay and to avoid necessity of removing and replacing construction to accommodate testing and inspecting.
 - 1. Schedule times for tests, inspections, obtaining samples, and similar activities.

1.8 SPECIAL TESTS AND INSPECTIONS

- A. Special Tests and Inspections: Conducted by a qualified testing agency as required by authorities having jurisdiction, as indicated in individual Specification Sections, and as follows:
 - 1. Verifying that manufacturer maintains detailed fabrication and quality-control procedures and reviewing the completeness and adequacy of those procedures to perform the Work.
 - 2. Notifying Architect and Contractor promptly of irregularities and deficiencies observed in the Work during performance of its services.
 - 3. Submitting a certified written report of each test, inspection, and similar quality-control service to Architect with copy to Contractor and to authorities having jurisdiction.
 - 4. Submitting a final report of special tests and inspections at Substantial Completion, which includes a list of unresolved deficiencies.
 - 5. Interpreting tests and inspections and stating in each report whether tested and inspected work complies with or deviates from the Contract Documents.
 - 6. Retesting and re-inspecting corrected work.

PART 2 - PRODUCTS (Not Used)

PART 3 - EXECUTION

3.1 TEST AND INSPECTION LOG

- A. Prepare a record of tests and inspections. Include the following:
 - 1. Date test or inspection was conducted.
 - 2. Description of the Work tested or inspected.
 - 3. Date test or inspection results were transmitted to Architect.
 - 4. Identification of testing agency or special inspector conducting test or inspection.
- B. Maintain log at Project site. Post changes and modifications as they occur. Provide access to test and inspection log for Architect's reference during normal working hours.

3.2 REPAIR AND PROTECTION

- A. General: On completion of testing, inspecting, sample taking, and similar services, repair damaged construction and restore substrates and finishes.
 - 1. Provide materials and comply with installation requirements specified in other Specification Sections. Restore patched areas and extend restoration into adjoining areas with durable seams that are as invisible as possible.
 - 2. Comply with the Contract Document requirements for Division 01 Section "Cutting and Patching."
- B. Protect construction exposed by or for quality-control service activities.
- C. Repair and protection are Contractor's responsibility, regardless of the assignment of responsibility for quality-control services.

END OF SECTION 014000

SECTION 015000 - TEMPORARY FACILITIES AND CONTROLS

PART 1 - GENERAL

1.1 RELATED DOCUMENTS

- A. Drawings and general provisions of the Contract, including General and Supplementary Conditions and other Division 01 Specification Sections, apply to this Section.

1.2 SUMMARY

- A. This Section includes requirements for temporary utilities, support facilities, and security and protection facilities.

1.3 USE CHARGES

- A. Water Service: Owner to provide water service for water used by all entities for construction operations.
- B. Electric Power Service: Owner to provide electric power for electricity used by all entities for construction operations.

PART 2 - PRODUCTS

2.1 TEMPORARY FACILITIES

- A. Traffic Control: coordinate with the City of Mobile Traffic Engineering Department for permitting and other requirements associated with work zones in the ROW and street.
- B. Restroom Facilities: Contractor to provide and maintain portable restroom facilities on-site for their personnel.

PART 3 - EXECUTION

3.1 INSTALLATION, GENERAL

- A. Locate facilities where they will serve Project adequately and result in minimum interference with performance of the Work. Relocate and modify facilities as required by progress of the Work.
 - 1. Locate facilities to limit site disturbance as specified in Division 01 Section "Summary."
- B. Provide each facility ready for use when needed to avoid delay. Do not remove until facilities are no longer needed or are replaced by authorized use of completed permanent facilities.

3.2 TERMINATION, AND REMOVAL

- A. Termination and Removal: Remove each temporary facility when need for its service has ended, when it has been replaced by authorized use of a permanent facility, or no later than Substantial Completion. Complete or, if necessary, restore permanent construction that may have been delayed because of interference with temporary facility. Repair damaged Work, clean exposed surfaces, and replace construction that cannot be satisfactorily repaired.
1. Materials and facilities that constitute temporary facilities are property of Contractor. Owner reserves right to take possession of Project identification signs.
 2. At Substantial Completion, clean and renovate permanent facilities used during construction period. Comply with final cleaning requirements specified in Division 01 Section "Closeout Procedures."

END OF SECTION 015000

SECTION 016000 - PRODUCT REQUIREMENTS

PART 1 - GENERAL

1.1 RELATED DOCUMENTS

- A. Drawings and general provisions of the Contract, including General and Supplementary Conditions and other Division 01 Specification Sections, apply to this Section.

1.2 SUMMARY

- A. This Section includes administrative and procedural requirements for selection of products for use in Project; product delivery, storage, and handling; manufacturers' standard warranties on products; special warranties; product substitutions; and comparable products.
- B. Related Sections include the following:
 - 1. Divisions 02 through 49 Sections for specific requirements for warranties on products and installations specified to be warranted.

1.3 DEFINITIONS

- A. Products: Items purchased for incorporating into the Work, whether purchased for Project or taken from previously purchased stock. The term "product" includes the terms "material," "equipment," "system," and terms of similar intent.
 - 1. Named Products: Items identified by manufacturer's product name, including make or model number or other designation shown or listed in manufacturer's published product literature, that is current as of date of the Contract Documents.
 - 2. New Products: Items that have not previously been incorporated into another project or facility, except that products consisting of recycled-content materials are allowed, unless explicitly stated otherwise. Products salvaged or recycled from other projects are not considered new products.
 - 3. Comparable Product: Product that is demonstrated and approved through submittal process, or where indicated as a product substitution, to have the indicated qualities related to type, function, dimension, in-service performance, physical properties, appearance, and other characteristics that equal or exceed those of specified product.
- B. Substitutions: Changes in products, materials, equipment, and methods of construction from those required by the Contract Documents and proposed by Contractor. Requires Architect's approval prior to bid by.
- C. Basis-of-Design Product Specification: Where a specific manufacturer's product is named and accompanied by the words "basis of design," including make or model number or other designation, to establish the significant qualities related to type, function, dimension, in-service performance, physical properties, appearance, and other characteristics for purposes of evaluating comparable products of other named manufacturers.

1.4 SUBMITTALS

- A. Basis-of-Design Product Specification Submittal: Comply with requirements in Division 01 Section "Submittal Procedures." Show compliance with requirements.

1.5 QUALITY ASSURANCE

- A. Compatibility of Options: If Contractor is given option of selecting between two or more products for use on Project, product selected shall be compatible with products previously selected, even if previously selected products were also options.

1.6 PRODUCT DELIVERY, STORAGE, AND HANDLING

- A. Deliver, store, and handle products using means and methods that will prevent damage, deterioration, and loss, including theft. Comply with manufacturer's written instructions.
- B. Delivery and Handling:
 - 1. Schedule delivery to minimize long-term storage at Project site and to prevent overcrowding of construction spaces.
 - 2. Coordinate delivery with installation time to ensure minimum holding time for items that are flammable, hazardous, easily damaged, or sensitive to deterioration, theft, and other losses.
 - 3. Deliver products to Project site in an undamaged condition in manufacturer's original sealed container or other packaging system, complete with labels and instructions for handling, storing, unpacking, protecting, and installing.
 - 4. Inspect products on delivery to ensure compliance with the Contract Documents and to ensure that products are undamaged and properly protected.
- C. Storage:
 - 1. Store products to allow for inspection and measurement of quantity or counting of units.
 - 2. Store materials in a manner that will not endanger Project structure.
 - 3. Store products that are subject to damage by the elements, under cover in a weathertight enclosure above ground, with ventilation adequate to prevent condensation.
 - 4. Store cementitious products and materials on elevated platforms.
 - 5. Store foam plastic from exposure to sunlight, except to extent necessary for period of installation and concealment.
 - 6. Comply with product manufacturer's written instructions for temperature, humidity, ventilation, and weather-protection requirements for storage.
 - 7. Protect stored products from damage and liquids from freezing.
 - 8. Provide a secure location and enclosure at Project site for storage of materials and equipment by Owner's construction forces. Coordinate location with Owner.

1.7 PRODUCT WARRANTIES

- A. Warranties specified in other Sections shall be in addition to, and run concurrent with, other warranties required by the Contract Documents. Manufacturer's disclaimers and limitations on product warranties do not relieve Contractor of obligations under requirements of the Contract Documents.
 - 1. Manufacturer's Warranty: Preprinted written warranty published by individual manufacturer for a particular product and specifically endorsed by manufacturer to Owner.
 - 2. Special Warranty: Written warranty required by or incorporated into the Contract Documents, either to extend time limit provided by manufacturer's warranty or to provide more rights for Owner.

- B. Special Warranties: Prepare a written document that contains appropriate terms and identification, ready for execution. Submit a draft for approval before final execution.
 - 1. Manufacturer's Standard Form: Modified to include Project-specific information and properly executed.
 - 2. Refer to Divisions 02 through 49 Sections for specific content requirements and particular requirements for submitting special warranties.
- C. Submittal Time: Comply with requirements in Division 01 Section "Closeout Procedures."

PART 2 - PRODUCTS

2.1 PRODUCT SELECTION PROCEDURES

- A. General Product Requirements: Provide products that comply with the Contract Documents, that are undamaged and, unless otherwise indicated, that are new at time of installation.
 - 1. Provide products complete with accessories, trim, finish, fasteners, and other items needed for a complete installation and indicated use and effect.
 - 2. Standard Products: If available, and unless custom products or nonstandard options are specified, provide standard products of types that have been produced and used successfully in similar situations on other projects.
 - 3. Owner reserves the right to limit selection to products with warranties not in conflict with requirements of the Contract Documents.
 - 4. Where products are accompanied by the term "as selected," Architect will make selection.
 - 5. Where products are accompanied by the term "match sample," sample to be matched is Architect's.
 - 6. Descriptive, performance, and reference standard requirements in the Specifications establish "salient characteristics" of products.
- B. Product Selection Procedures:
 - 1. Available Products: Where Specifications include a list of names of both products and manufacturers, provide one of the products listed, or an unnamed product, that complies with requirements. Comply with provisions in Part 2 "Comparable Products" Article for consideration of an unnamed product.
 - 2. Available Manufacturers: Where Specifications include a list of manufacturers, provide a product by one of the manufacturers listed, or an unnamed manufacturer, that complies with requirements. Comply with provisions in Part 2 "Comparable Products" Article for consideration of an unnamed product.
 - 3. Basis-of-Design Product: Where Specifications name a product and include a list of manufacturers, provide the specified product or a comparable product by one of the other named manufacturers. Drawings and Specifications indicate sizes, profiles, dimensions, and other characteristics that are based on the product named. Comply with provisions in Part 2 "Comparable Products" Article for consideration of an unnamed product by the other named manufacturers.

PART 3 - EXECUTION (Not Used)

END OF SECTION 016000

SECTION 022200 - SELECTIVE DEMOLITION

PART 1 - GENERAL

1.1 SUMMARY

- A. This Section includes the following:

1. Demolition and removal of existing concrete apron and concrete sidewalk.

1.2 DEFINITIONS

- A. Remove: Detach items from existing construction and legally dispose of them off-site, unless indicated to be removed and salvaged or removed and reinstalled.
- B. Existing to Remain: Existing items of construction that are not to be removed and that are not otherwise indicated to be removed, removed, and salvaged, or removed and reinstalled.

1.3 SUBMITTALS

- A. Schedule of Selective Demolition Activities: Indicate detailed sequence of selective demolition and removal work, with starting and ending dates for each activity, interruption of utility services, interruption of ingress and egress from the facility, and interruption of traffic on Davenport Avenue.
- B. Pre-demolition Photographs or Videotapes: Show existing conditions of adjoining construction and site improvements, including finish surfaces that might be misconstrued as damage caused by selective demolition operations.

1.4 PROJECT CONDITIONS

- A. Owner will occupy portions of site immediately adjacent to selective demolition area. Conduct selective demolition so Owner's operations will not be disrupted.
- B. Contractor is responsible for coordination of street closures and or disruptions with the City of Mobile Traffic Engineering.
- C. Notify Architect of discrepancies between existing conditions and Drawings before proceeding with selective demolition.
- D. Hazardous Materials: It is not expected that hazardous materials will be encountered in the Work.
 1. If materials suspected of containing hazardous materials are encountered, do not disturb; immediately notify Architect and Owner. Owner will remove hazardous materials under a separate contract.
- E. Storage or sale of removed items or materials on-site is not permitted.

PART 2 - PRODUCTS (Not Used)

PART 3 - EXECUTION

3.1 EXAMINATION

- A. Survey existing conditions and correlate with requirements indicated to determine extent of selective demolition required. Notify Architect of any deviations or problems observed before and during construction.

3.2 PREPARATION

- A. Temporary Facilities: Provide temporary barricades and other protection required to prevent injury to people and damage to adjacent roadway, ROS and facilities to remain.

3.3 SELECTIVE DEMOLITION

- A. General: Demolish and remove existing construction only to the extent required by new construction and as indicated:
 - 1. Neatly cut openings and holes plumb, square, and true to dimensions required. Use cutting methods least likely to damage construction to remain or adjoining construction. Use hand tools or small power tools designed for sawing or grinding, not hammering and chopping, to minimize disturbance of adjacent surfaces. Temporarily cover openings to remain.
 - 2. Locate selective demolition equipment and remove debris and materials so as not to impose excessive loads on supporting walls, floors, or framing.
 - 3. Dispose of demolished items and materials promptly.

- B. Existing Items to Remain: Protect construction indicated to remain against damage and soiling during selective demolition.

3.4 DISPOSAL OF DEMOLISHED MATERIALS

- A. General: Except for items or materials indicated to be recycled, reused, salvaged, reinstalled, or otherwise indicated to remain Owner's property, remove demolished materials from Project site and legally dispose of them in an EPA-approved landfill.
- B. Burning: Do not burn demolished materials.
- C. Disposal: Transport demolished materials off Owner's property and legally dispose of them.

3.5 CLEANING

- A. Clean adjacent structures and improvements of dust, dirt, and debris caused by selective demolition operations. Return adjacent areas to condition existing before selective demolition operations began.

END OF SECTION 022200

SECTION 321613 - CONCRETE SIDEWALKS AND CURBS

PART 1 - GENERAL

1.1 RELATED DOCUMENTS

- A. Drawings and general provisions of the Contract, including General and Supplementary Conditions and Division 01 Specification Sections, apply to this Section.

1.2 SUMMARY

- A. Section Includes:
 - B. Driveways.
 - C. Curbs and gutters.
 - D. Walks.
- E. Related Sections:
- F. Division 03 Section "Cast-in-Place Concrete" for general building applications of concrete.

1.3 DEFINITIONS

- A. Cementitious Materials: Portland cement alone or in combination with one or more of blended hydraulic cement, fly ash and other pozzolans, and ground granulated blast-furnace slag.

1.4 SUBMITTALS

- A. Product Data: For each type of product indicated.
- B. Other Action Submittals:
 - 1. Design Mixtures: For each concrete paving mixture. Include alternate design mixtures when characteristics of materials, Project conditions, weather, test results, or other circumstances warrant adjustments.
 - 2. Material Certificates: For the following, from manufacturer:
 - a. Cementitious materials.
 - b. Steel reinforcement and reinforcement accessories.
 - c. Fiber reinforcement.
 - d. Admixtures.
 - e. Curing compounds.
 - f. Applied finish materials.
 - g. Bonding agent or epoxy adhesive.
 - h. Joint fillers.
- C. Field quality-control reports.

1.5 QUALITY ASSURANCE

- A. Ready-Mix-Concrete Manufacturer Qualifications: A firm experienced in manufacturing ready-mixed concrete products and that complies with ASTM C 94/C 94M requirements for production facilities and equipment.
- B. Testing Agency Qualifications: Qualified according to ASTM C 1077 and ASTM E 329 for testing indicated.
- C. Personnel conducting field tests shall be qualified as ACI Concrete Field Testing Technician, Grade 1, according to ACI CP-1 or an equivalent certification program.
- D. Concrete Testing Service: Engage a qualified testing agency to perform material evaluation tests and to design concrete mixtures.

- E. ACI Publications: Comply with ACI 301 unless otherwise indicated.

1.6 PROJECT CONDITIONS

- A. Traffic Control: Maintain access for vehicular and pedestrian traffic as required for other construction activities.

PART 2 - PRODUCTS

2.1 FORMS

- A. Form Materials: Plywood, metal, metal-framed plywood, or other approved panel-type materials to provide full-depth, continuous, straight, and smooth exposed surfaces.
 - 1. Use flexible or uniformly curved forms for curves with a radius of 100 feet or less. Do not use notched and bent forms.
- B. Form-Release Agent: Commercially formulated form-release agent that will not bond with, stain, or adversely affect concrete surfaces and that will not impair subsequent treatments of concrete surfaces.

2.2 STEEL REINFORCEMENT

- A. Plain-Steel Welded Wire Reinforcement: ASTM A 185/A 185M, fabricated from steel wire into flat sheets.
- B. Reinforcing Bars: ASTM A 615/A 615M, Grade 60; deformed.
- C. Plain-Steel Wire: ASTM A 82/A 82M.
- D. Deformed-Steel Wire: ASTM A 496/A 496M.
- E. Joint Dowel Bars: ASTM A 615/A 615M, Grade 60 plain-steel bars. Cut bars true to length with ends square and free of burrs.
- F. Tie Bars: ASTM A 615/A 615M, Grade 60, deformed.
- G. Hook Bolts: ASTM A 307, Grade A, internally and externally threaded. Design hook-bolt joint assembly to hold coupling against paving form and in position during concreting operations, and to permit removal without damage to concrete or hook bolt.
- H. Bar Supports: Bolsters, chairs, spacers, and other devices for spacing, supporting, and fastening reinforcing bars, welded wire reinforcement, and dowels in place. Manufacture bar supports according to CRSI's "Manual of Standard Practice" from steel wire, plastic, or pre-cast concrete of greater compressive strength than concrete specified, and as follows:

2.3 CONCRETE MATERIALS AND MIX

- A. Concrete shall meet the requirements of a Class A, Type 2 mix as provide in Section 501 of ALDOT Standard Specifications for Highway Construction, 2008 Edition.
- B. All concrete shall have a minimum compressive strength of 4,000 psi at 28 days.

2.4 CURING MATERIALS

- A. Moisture-Retaining Cover: ASTM C 171, polyethylene film or white burlap-polyethylene sheet.
- B. Water: Potable.

2.5 RELATED MATERIALS

- A. Joint Fillers: Shall be in accordance with ALDOT Standard Specifications for Highway Construction, 2008 Edition, Section 618 and 623.

2.6 DETECTABLE WARNING MATERIALS

- A. Detectable Warning Mat: Pre-fabricated composite tactile warning surface with truncated domes spacing not to exceed 2.35".
 - 1. Size of Mat: One piece, 24 by 36 inches.

2.7 CONCRETE MIXING

- A. Ready-Mixed Concrete: Measure, batch, and mix concrete materials and concrete according to ASTM C 94/C 94M. Furnish batch certificates for each batch discharged and used in the Work.
 - 1. When air temperature is between 85 and 90 deg F, reduce mixing and delivery time from 1-1/2 hours to 75 minutes; when air temperature is above 90 deg F, reduce mixing and delivery time to 60 minutes.

PART 3 - EXECUTION

3.1 EXAMINATION

- A. Examine exposed subgrades and subbase surfaces for compliance with requirements for dimensional, grading, and elevation tolerances.

3.2 PREPARATION

- A. Remove loose material from compacted subbase surface immediately before placing concrete.
- B. Remove any construction debris and standing water from the work area. If standing water is removed, verify the subgrade integrity prior to installation.

3.3 EDGE FORMS AND SCREED CONSTRUCTION

- A. Set, brace, and secure edge forms, bulkheads, and intermediate screed guides to required lines, grades, and elevations. Install forms to allow continuous progress of work and so forms can remain in place at least 24 hours after concrete placement.
- B. Clean forms after each use and coat with form-release agent to ensure separation from concrete without damage.

3.4 STEEL REINFORCEMENT

- A. Install welded wire reinforcement in lengths as long as practicable. Lap adjoining pieces at least one full mesh, and lace splices with wire. Offset laps of adjoining widths to prevent continuous laps in either direction.

3.5 JOINTS

- A. General: Form construction, isolation, and contraction joints and tool edges true to line, with faces perpendicular to surface plane of concrete. Construct transverse joints at right angles to centerline unless otherwise indicated.
 - 1. When joining existing sidewalk, installed 18" dowels into existing concrete and anchor with an appropriate epoxy adhesive. 8" minimum embedment is required.
- B. Construction Joints: Set construction joints at side and end terminations of paving and at locations where paving operations are stopped for more than one-half hour unless paving terminates at isolation joints.
 - 1. Continue steel reinforcement across construction joints unless otherwise indicated. Do not continue reinforcement through sides of paving strips unless otherwise indicated.
- C. Doweled Joints: Install dowel bars and support assemblies at joints where indicated. Lubricate or coat with asphalt one-half of dowel length to prevent concrete bonding to one side of joint.

- D. Expansion Joints: Form expansion joints of preformed joint-filler strips abutting concrete curbs, structures, other fixed objects, and where indicated.
 - 1. Locate expansion joints at intervals of 80 feet unless otherwise indicated.
 - 2. Extend joint fillers full width and depth of joint.
 - 3. Terminate joint filler not less than 1/2 inch or more than 1 inch below finished surface if joint sealant is indicated.
 - 4. Place top of joint filler flush with finished concrete surface if joint sealant is not indicated.
 - 5. Furnish joint fillers in one-piece lengths. Where more than one length is required, lace or clip joint-filler sections together.
 - 6. During concrete placement, protect top edge of joint filler with metal, plastic, or other temporary preformed cap. Remove protective cap after concrete has been placed on both sides of joint.
- E. Contraction Joints: Form weakened-plane contraction joints, sectioning concrete into areas as indicated. Construct contraction joints for a depth equal to at least one-fourth of the concrete thickness, as follows:
- F. Grooved Joints: Form contraction joints after initial floating by grooving and finishing each edge of joint with grooving tool to a 1/4-inch radius. Repeat grooving of contraction joints after applying surface finishes.

3.6 CONCRETE PLACEMENT

- A. Before placing concrete, inspect and complete formwork installation, steel reinforcement, and items to be embedded or cast-in.
- B. Remove snow, ice, or frost from subbase surface and steel reinforcement before placing concrete. Do not place concrete on frozen surfaces.
- C. Moisten subbase to provide a uniform dampened condition at time concrete is placed. Do not place concrete around manholes or other structures until they are at required finish elevation and alignment.
- D. Comply with ACI 301 requirements for measuring, mixing, transporting, and placing concrete.
- E. Deposit and spread concrete in a continuous operation between transverse joints. Do not push or drag concrete into place or use vibrators to move concrete into place.
- F. Consolidate concrete according to ACI 301 by mechanical vibrating equipment supplemented by hand spading, rodding, or tamping.
- G. Screed sidewalk surface with a straightedge and strike off.
- H. Curbs and Gutters: Use design mixture for automatic machine placement. Produce curbs and gutters to required cross section, lines, grades, finish, and jointing.
- I. Cold-Weather Placement: Protect concrete work from physical damage or reduced strength that could be caused by frost, freezing, or low temperatures. Comply with ACI 306.1 and the following:
- J. When air temperature has fallen to or is expected to fall below 40 deg F, uniformly heat water and aggregates before mixing to obtain a concrete mixture temperature of not less than 50 deg F and not more than 80 deg F at point of placement.
- K. Do not use frozen materials or materials containing ice or snow.
- L. Do not use calcium chloride, salt, or other materials containing antifreeze agents or chemical accelerators unless otherwise specified and approved in design mixtures.
- M. Hot-Weather Placement: Comply with ACI 301 and as follows when hot-weather conditions exist:
 - 1. Cool ingredients before mixing to maintain concrete temperature below 90 deg F at time of placement. Chilled mixing water or chopped ice may be used to control temperature, provided water equivalent of ice is calculated in total amount of mixing water. Using liquid nitrogen to cool concrete is Contractor's option.
 - 2. Cover steel reinforcement with water-soaked burlap so steel temperature will not exceed ambient air temperature immediately before embedding in concrete.

3.7 FLOAT FINISHING

- A. General: Do not add water to concrete surfaces during finishing operations.
- B. Float Finish: Begin the second floating operation when bleed-water sheen has disappeared and concrete surface has stiffened sufficiently to permit operations. Float surface with power-driven floats or by hand floating if area is small or inaccessible to power units. Finish surfaces to true planes. Cut down high spots and fill low spots. Refloat surface immediately to uniform granular texture.
- C. Medium-to-Fine-Textured Broom Finish: Draw a soft-bristle broom across float-finished concrete surface perpendicular to line of traffic to provide a uniform, fine-line texture.

3.8 DETECTABLE WARNINGS

- A. Detectable Warning Mats: Install detectable warning mats as part of a continuous concrete paving placement and according to mat manufacturer's written instructions.

3.9 CONCRETE PROTECTION AND CURING

- A. General: Protect freshly placed concrete from premature drying and excessive cold or hot temperatures.
- B. Comply with ACI 306.1 for cold-weather protection.
- C. Apply plastic sheeting to concrete surfaces if hot, dry, or windy conditions could cause excessive moisture loss to occur.
- D. Begin curing after finishing concrete but not before free water has disappeared from concrete surface.

3.10 PAVING TOLERANCES

- A. Comply with tolerances in ACI 117 and as follows:
 - 1. Elevation: 3/4 inch
 - 2. Thickness: Plus 3/8 inch, minus 1/4 inch.
 - 3. Surface: Gap below 10-foot-long, unlevelled straightedge not to exceed 1/2 inch.
 - 4. Lateral Alignment and Spacing of Dowels: 1 inch.
 - 5. Vertical Alignment of Dowels: 1/4 inch.
 - 6. Joint Spacing: 3 inches.
 - 7. Contraction Joint Depth: Plus 1/4 inch, no minus.
 - 8. Joint Width: Plus 1/8 inch, no minus.

3.11 FIELD QUALITY CONTROL

- A. Testing Agency: Owner will engage a qualified testing agency to perform tests and inspections.
- B. Testing Services: Testing of composite samples of fresh concrete obtained according to ASTM C 172 shall be performed according to the following requirements:
- C. Testing Frequency: Obtain at least one composite sample for each 100 cu. yd. or fraction thereof of each concrete mixture placed each day.
 - 1. When frequency of testing will provide fewer than five compressive-strength tests for each concrete mixture, testing shall be conducted from at least five randomly selected batches or from each batch if fewer than five are used.
- D. Slump: ASTM C 143/C 143M; one test at point of placement for each composite sample, but not less than one test for each day's pour of each concrete mixture. Perform additional tests when concrete consistency appears to change.
- E. Air Content: ASTM C 231, pressure method; one test for each composite sample, but not less than one test for each day's pour of each concrete mixture.
- F. Concrete Temperature: ASTM C 1064/C 1064M; one test hourly when air temperature is 40 deg F and below and when it is 80 deg F and above, and one test for each composite sample.

- G. Compression Test Specimens: ASTM C 31/C 31M; cast and laboratory cure one set of three standard cylinder specimens for each composite sample.
- H. Compressive-Strength Tests: ASTM C 39/C 39M; test one specimen at seven days and two specimens at 28 days.
 - 1. A compressive-strength test shall be the average compressive strength from two specimens obtained from same composite sample and tested at 28 days.
 - 2. Strength of each concrete mixture will be satisfactory if average of any three consecutive compressive-strength tests equals or exceeds specified compressive strength and no compressive-strength test value falls below specified compressive strength by more than 500 psi.
 - 3. Test results shall be reported in writing to Architect, concrete manufacturer, and Contractor within 48 hours of testing. Reports of compressive-strength tests shall contain Project identification name and number, date of concrete placement, name of concrete testing and inspecting agency, location of concrete batch in Work, design compressive strength at 28 days, concrete mixture proportions and materials, compressive breaking strength, and type of break for both 7- and 28-day tests.
 - 4. Additional Tests: Testing and inspecting agency shall make additional tests of concrete when test results indicate that slump, air entrainment, compressive strengths, or other requirements have not been met, as directed by Engineer.
 - 5. Concrete paving will be considered defective if it does not pass tests and inspections.
 - 6. Additional testing and inspecting, at Contractor's expense, will be performed to determine compliance of replaced or additional work with specified requirements.
 - 7. Prepare test and inspection reports.

3.12 REPAIRS AND PROTECTION

- A. Remove and replace concrete paving that is broken, damaged, or defective or that does not comply with requirements in this Section. Remove work in complete sections from joint to joint unless otherwise approved by Architect.
- B. Drill test cores, where directed by Architect, when necessary to determine magnitude of cracks or defective areas. Fill drilled core holes in satisfactory paving areas with portland cement concrete bonded to paving with epoxy adhesive.
- C. Protect concrete paving from damage. Exclude traffic from paving for at least 14 days after placement. When construction traffic is permitted, maintain paving as clean as possible by removing surface stains and spillage of materials as they occur.
- D. Maintain concrete paving free of stains, discoloration, dirt, and other foreign material. Sweep paving not more than two days before date scheduled for Substantial Completion inspections.

END OF SECTION 321613

1/7/2022 4:07:10 PM - \\lco\shoredfiles\Projects\2021\Projects\1101\21-1101-0232 CoM Crichton Fire Station Apron Repairs\Working\Architectural\04 Contract Document\Phase\Drawings\G100.0 Cover Sheet NEW.dwg

CITY OF MOBILE

PROJECT NUMBER FD-072-21

CRICHTON FIRE STATION - DRIVE REPAIR

200 DAVENPORT AVENUE, MOBILE, ALABAMA 36607

ISSUED FOR BID FEBRUARY 4, 2022

DRAWING INDEX

GENERAL

G100.0 COVER SHEET & DRAWING INDEX

CIVIL

C100	DAVENPORT AVE DEMOLITION AND SITE IMPROVEMENT
C101	HAAS AVE DEMOLITION AND SITE IMPROVEMENT
C200	DETAILS
C201	DETAILS

DESIGN TEAM

ARCHITECTURAL:

Watermark Design Group, LLC
2970 Cottage Hill Road, Suite 200
Mobile, Alabama 36606
(251) 344-5515

ARCHITECT: John A. McArthur III, AIA

CIVIL:

Thompson Engineering
2970 Cottage Hill Road, Suite 190
Mobile, Alabama 36606
(251) 666-2443

CIVIL ENGINEER: FRANK LEATHERWOOD, PE

watermark
DESIGN GROUP LLC
architecture • interior design
2970 cottage hill road, suite 200 mobile, alabama
251.344.5515 voice 251.344.5140 text/fax

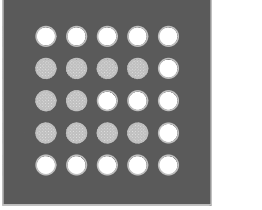

CITY OF MOBILE
PROJECT NUMBER FD-072-21
CRICHTON FIRE STATION - DRIVE REPAIR
200 DAVENPORT AVENUE, MOBILE, ALABAMA 36607

PROJECT NO: 21-0232

REVISIONS:

ISSUE DATE: 2-4-22

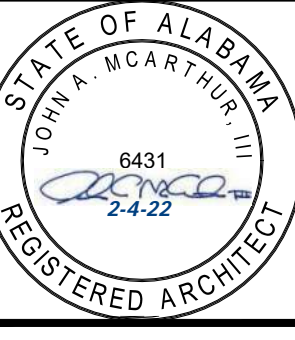

THIS DRAWING REPRESENTS DESIGN PREPARED BY WATERMARK DESIGN GROUP LLC FOR SPECIFIC USE ON THIS PROJECT AND IS NOT TO BE COPIED, REPRODUCED, OR ALTERED WITHOUT THE EXPRESS WRITTEN CONSENT OF THE WATERMARK DESIGN GROUP REPRESENTATIVE AUTHORIZED TO APPROVE THIS USE. UNAUTHORIZED USE IS SUBJECT TO LEGAL ACTION UNDER STATE AND FEDERAL LAW.

SHEET TITLE:
COVER SHEET AND DRAWING INDEX

SHEET NUMBER:
G100.0

VICINITY MAP

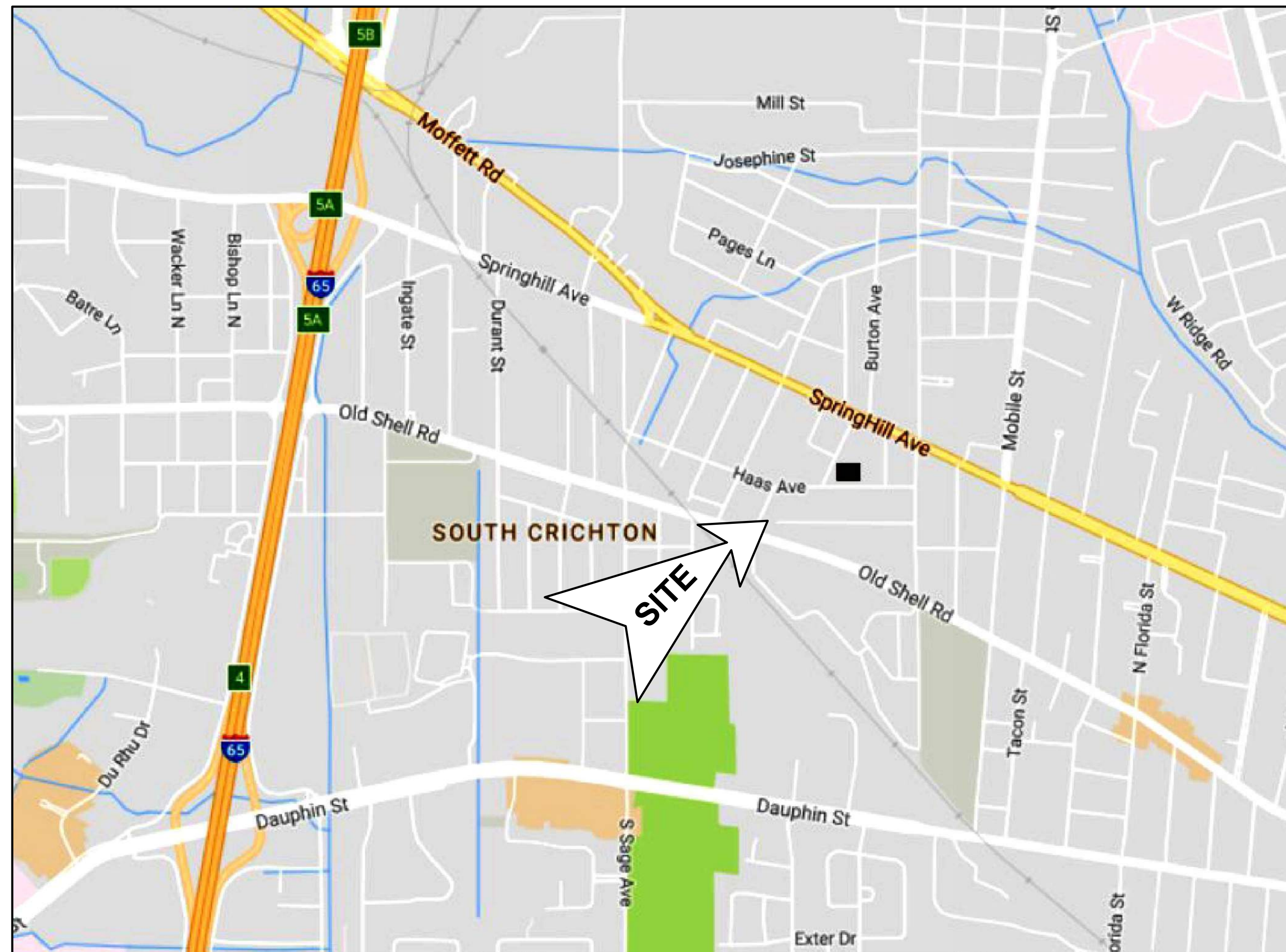

SITE MAP

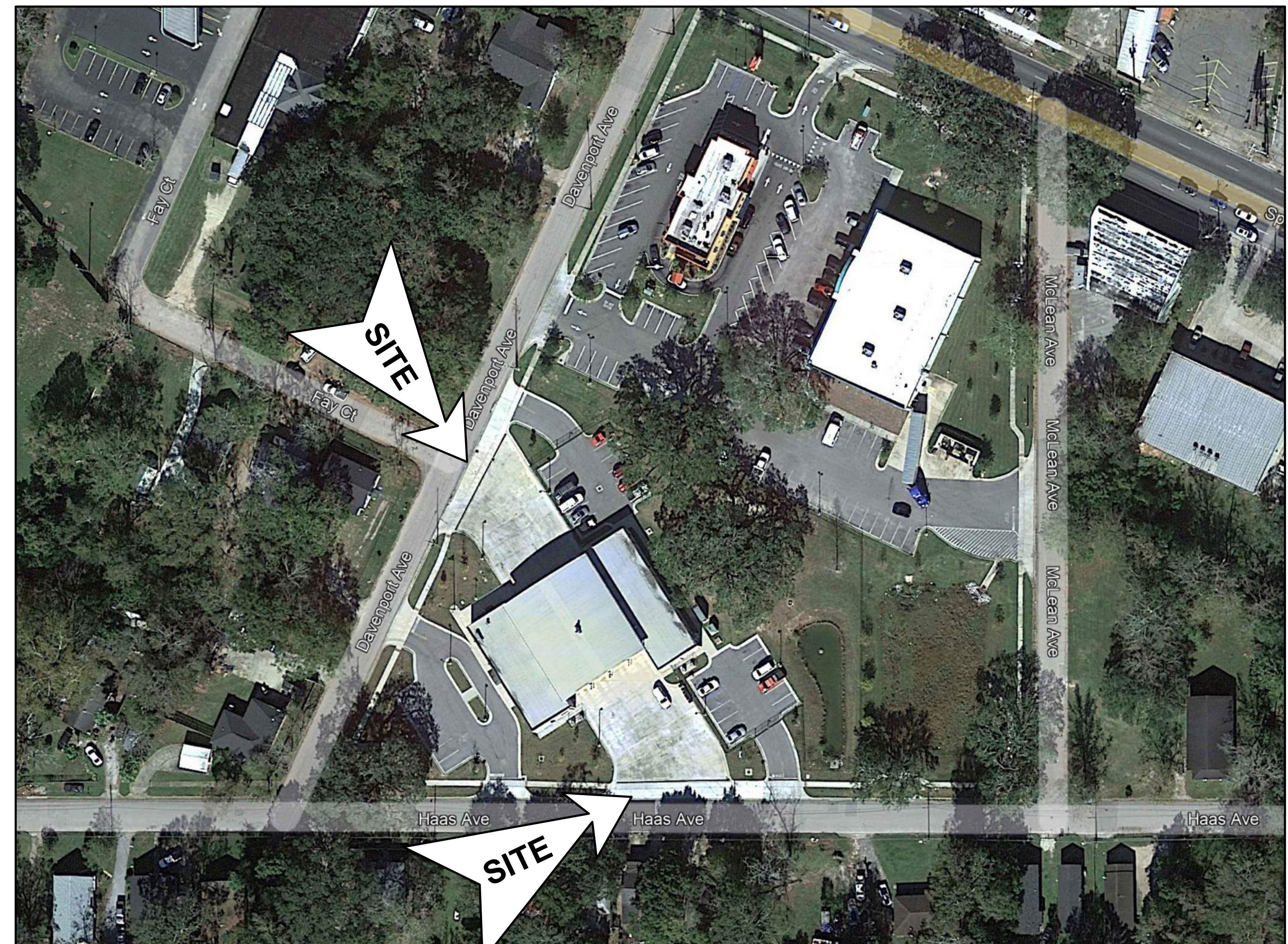

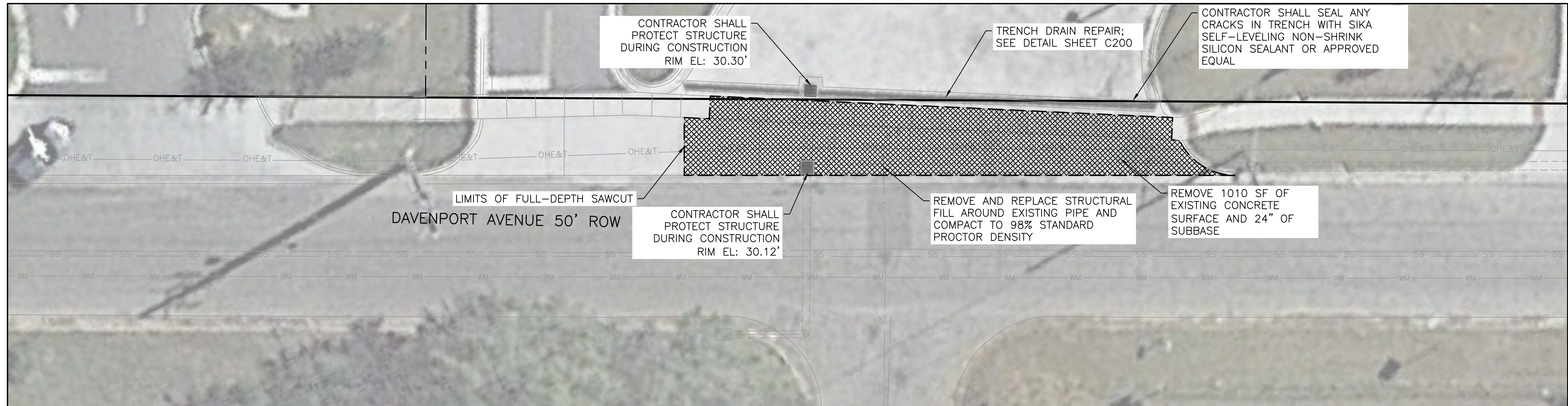

EXISTING CONDITION AND DEMOLITION PLAN

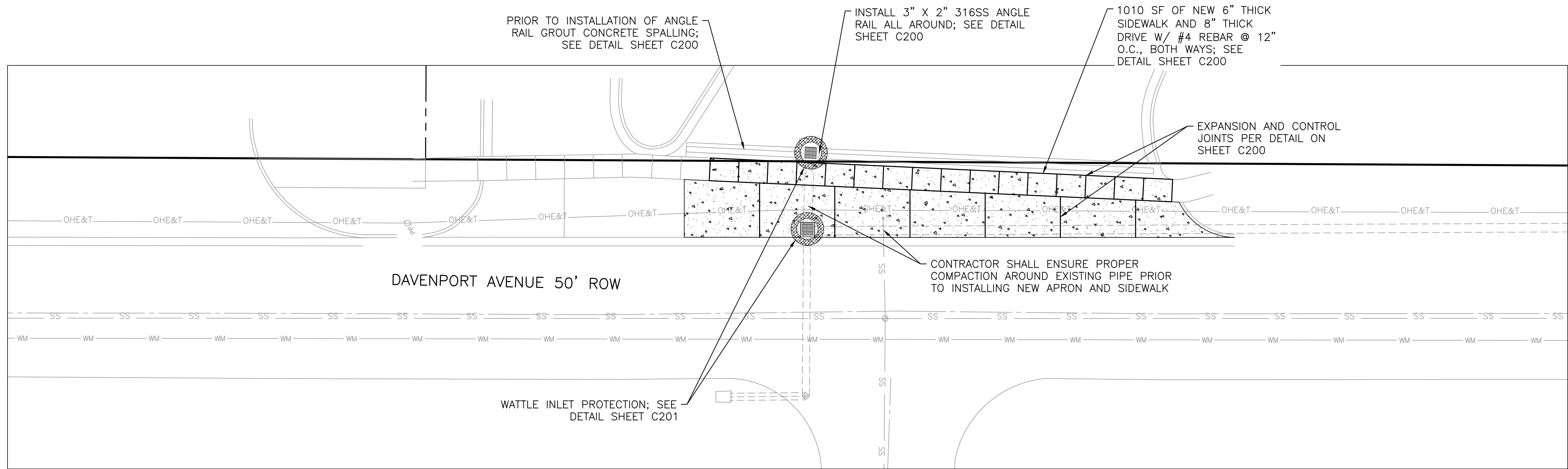
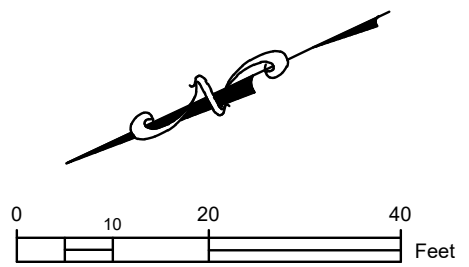

NEW DRIVE AND SIDEWALK PLAN

P:\2021\Projects\1101\21-1101-0232 CoM Crichton Fire Station Apron Repairs Working Civil Drawings

THIS DRAWING REPRESENTS DESIGNS PREPARED BY THOMPSON ENGINEERING FOR SPECIFIC USE ON THIS PROJECT AND IS NOT TO BE COPIED, REPRODUCED, OR ALTERED WITHOUT THE EXPRESS WRITTEN CONSENT OF THE THOMPSON ENGINEERING REPRESENTATIVE AUTHORIZED TO APPROVE THIS USE. UNAUTHORIZED USE IS SUBJECT TO LEGAL ACTION UNDER STATE AND FEDERAL LAW.

REVISION NO.	DESCRIPTION	DATE	BY:
A	ISSUED FOR APPROVAL	12/7/21	FL
0	ISSUED FOR BID	12/20/21	FL



CITY OF MOBILE
MOBILE, ALABAMA

thompson
ENGINEERING

2970 COTTAGE HILL RD., STE. 190
MOBILE, ALABAMA 36606

TEL: (251) 666-2443
FAX: (251) 666-6422

SCALE:	PLOT SCALE:	DRAWN BY:	CHECKED BY:	APPROVED BY:	DATE:	JOB NO.:	DRAWING NO.:	REVISION NO.:
	1:1	BC	SM	FL	FEBRUARY 4, 2022	21-1101-0232	C100	0

CITY OF MOBILE
CRICHTON FIRE STATION
DRIVE REPAIR
DAVENPORT AVENUE DEMOLITION
AND SITE IMPROVEMENT SHEET

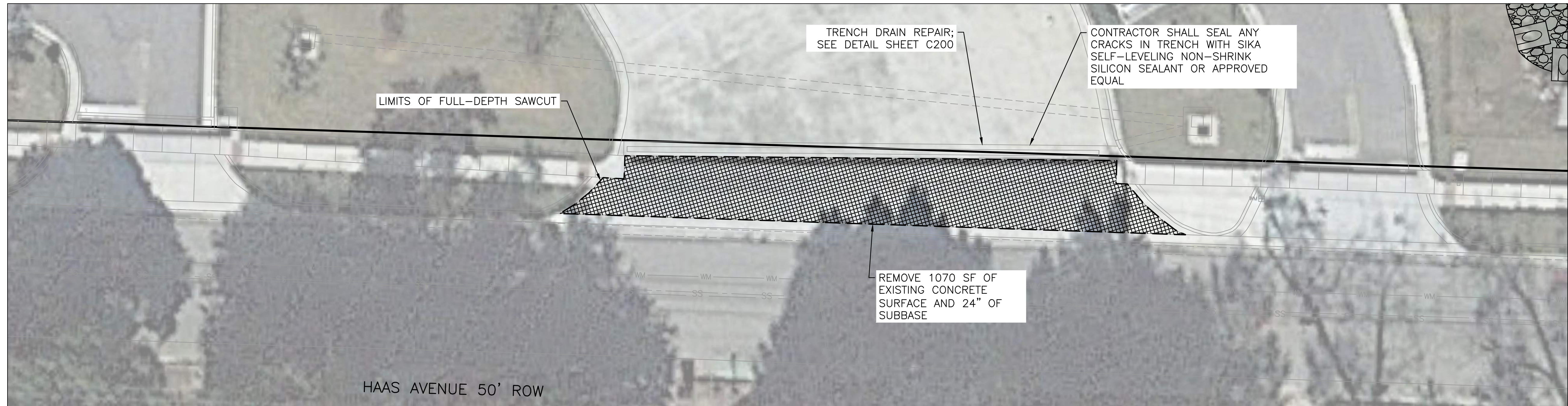

EXISTING CONDITION AND DEMOLITION PLAN

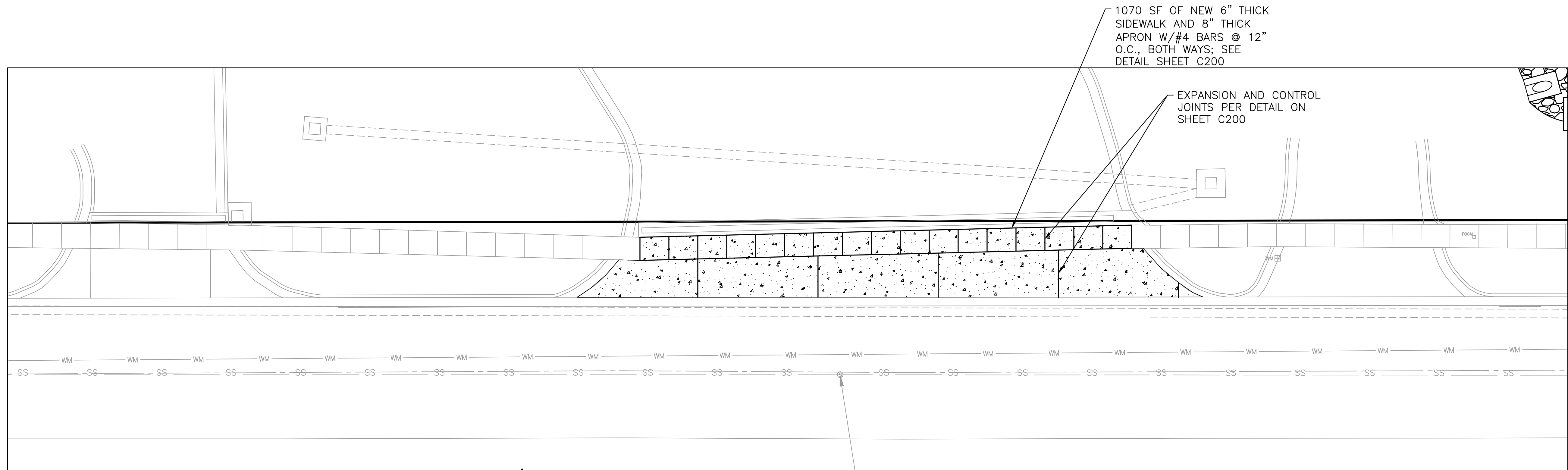

NEW DRIVE AND SIDEWALK PLAN

P:\2021\Projects\1101\21-1101-0232 CoM Crichton Fire Station Apron Repairs Working Civil Drawings

THIS DRAWING REPRESENTS DESIGNS PREPARED BY THOMPSON ENGINEERING FOR SPECIFIC USE ON THIS PROJECT AND IS NOT TO BE COPIED, REPRODUCED, OR ALTERED WITHOUT THE EXPRESS WRITTEN CONSENT OF THE THOMPSON ENGINEERING REPRESENTATIVE AUTHORIZED TO APPROVE THIS USE. UNAUTHORIZED USE IS SUBJECT TO LEGAL ACTION UNDER STATE AND FEDERAL LAW.

REVISION NO. A	DESCRIPTION ISSUED FOR APPROVAL	DATE 12/7/21	BY: FL
REVISION NO. 0	DESCRIPTION ISSUED FOR BID	DATE 12/20/21	BY: FL
REVISION NO.	DESCRIPTION	DATE	BY:
REVISION NO.	DESCRIPTION	DATE	BY:
REVISION NO.	DESCRIPTION	DATE	BY:



CITY OF MOBILE
MOBILE, ALABAMA

thompson
ENGINEERING

2970 COTTAGE HILL RD., STE. 190
MOBILE, ALABAMA 36606

TEL: (251) 666-2443
FAX: (251) 666-6422

SCALE:	PLOT SCALE: 1:1	DRAWN BY: BC	CHECKED BY: SM	APPROVED BY: FL	DATE: FEBRUARY 4, 2022	JOB NO.: 21-1101-0232	DRAWING NO.: C101	REVISION NO.: 0
--------	-----------------	--------------	----------------	-----------------	------------------------	-----------------------	-------------------	-----------------

CITY OF MOBILE
CRICHTON FIRE STATION
DRIVE REPAIR
HAAS AVENUE DEMOLITION AND
SITE IMPROVEMENT SHEET

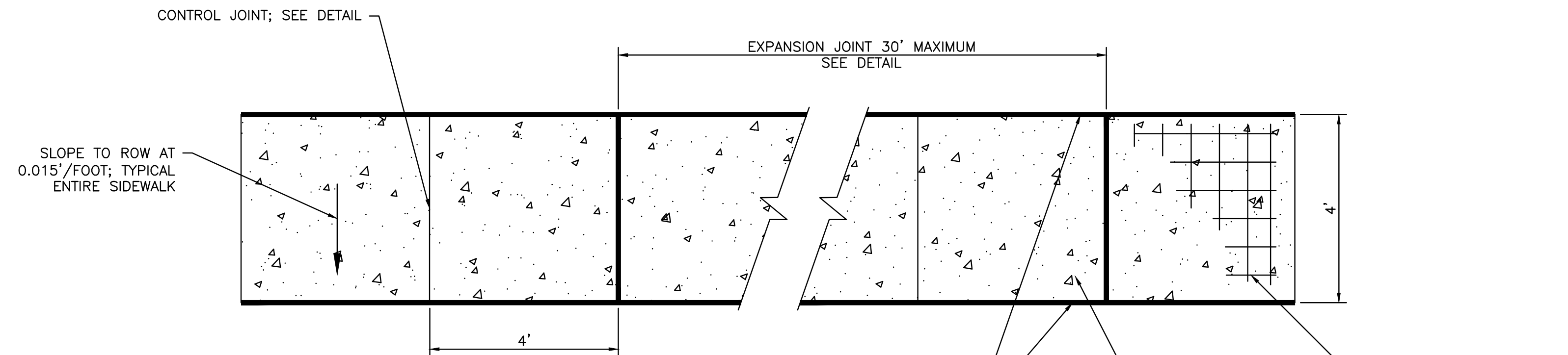

SIDEWALK NOTE:

1. SIDEWALK SHALL HAVE EXPANSION JOINT BETWEEN SIDEWALK AND TRENCH DRAIN AND SIDEWALK AND APRON.
2. MINIMUM 4000 PSI CONCRETE WITH NATURAL COLOR AND BROOM FINISH TO MATCH EXISTING.
3. MINIMUM THICKNESS OF SIDEWALK IS 6" THICK W/ 8" TURNDOWNS.
4. EDGE OF SIDEWALK SHALL HAVE 1/4" RADIUS.

SIDEWALK PLAN VIEW DETAIL
N.T.S.

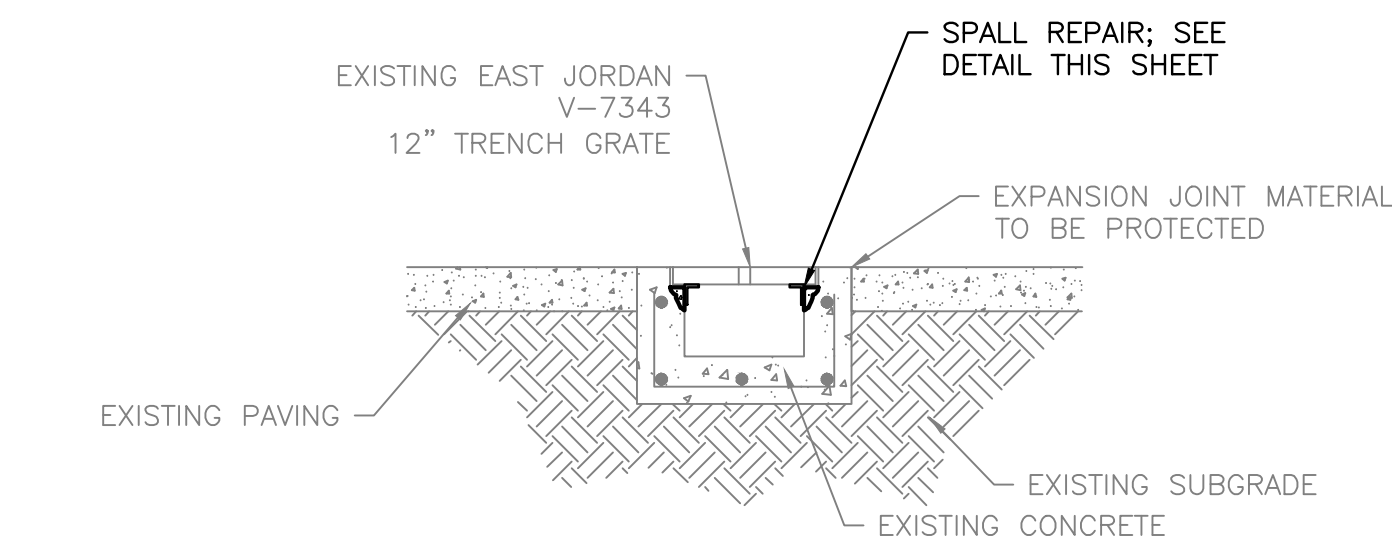

TRENCH DRAIN SECTION
N.T.S.

GROUTING NOTE:

1. CONTRACTOR SHALL CLEAN EXISTING CONCRETE SURFACE IN TRENCH DRAIN OF ANY DEBRIS TO ENSURE PROPER ADHESION OF GROUT.
2. CONTRACTOR SHALL USE SIKAGUICK 1000 RAPID HARDENING MORTAR OR EOR APPROVED EQUAL.
3. CONTRACTOR SHALL WAIT 24 HRS FOR MORTAR TO CURE BEFORE ATTACHING ANGLE IRON AND ANCHOR BOLTS.
4. ANCHOR BOLTS SHALL HAVE 12" O.C. SPACING.
5. CONTRACTOR SHALL SEAL ALL CRACKS IN TRENCH DRAIN WITH NON-SHRINK SILICON.

SPALL REPAIR DETAIL
N.T.S.

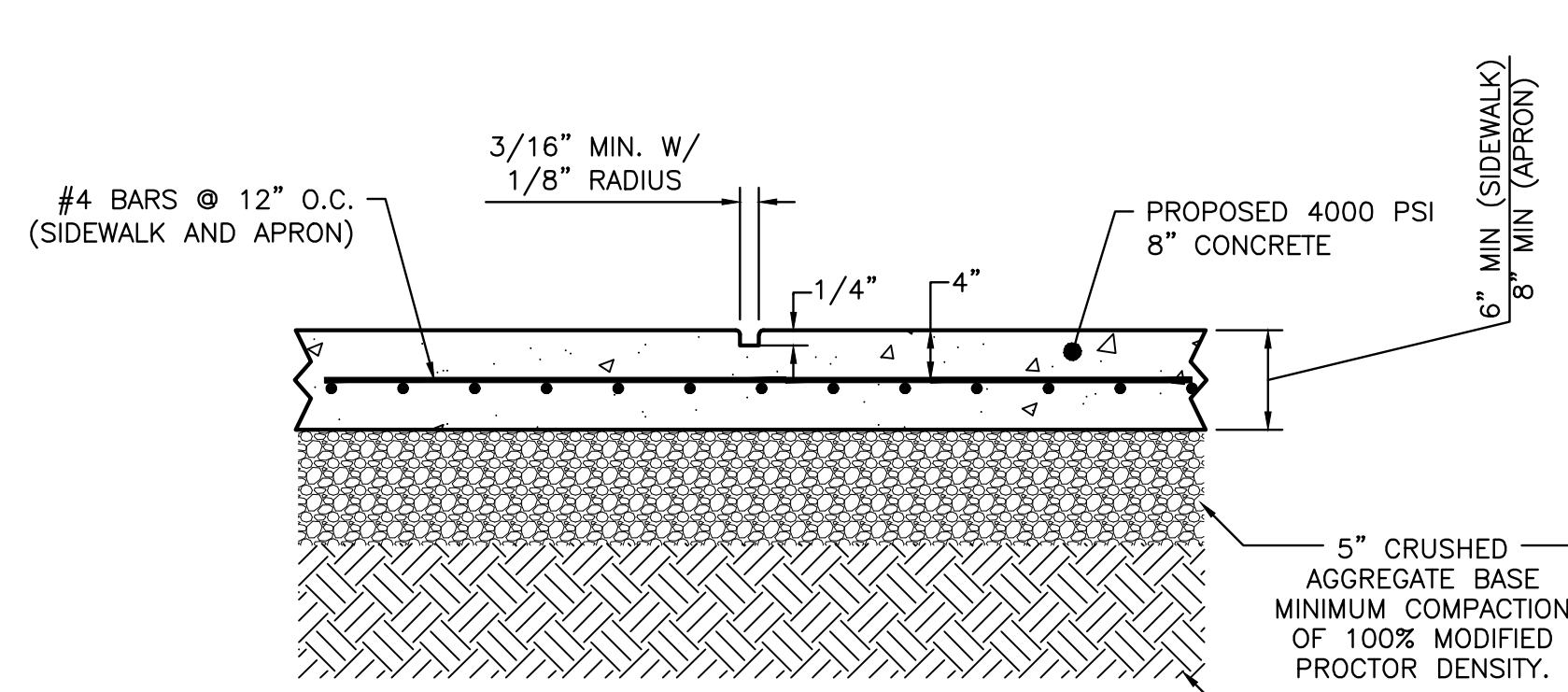
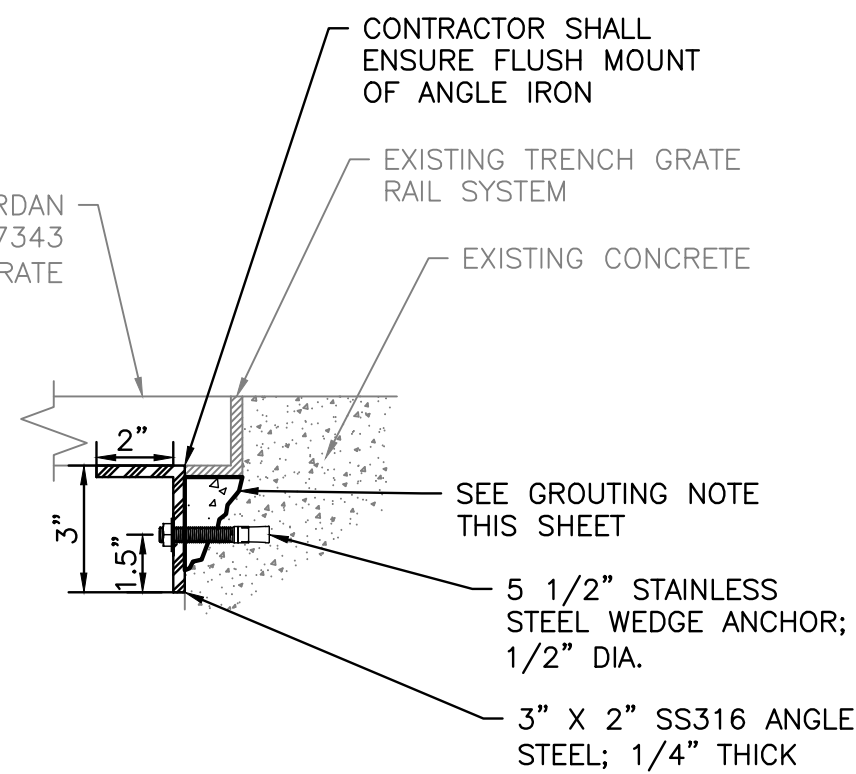

CONTROL JOINT DETAIL
N.T.S.

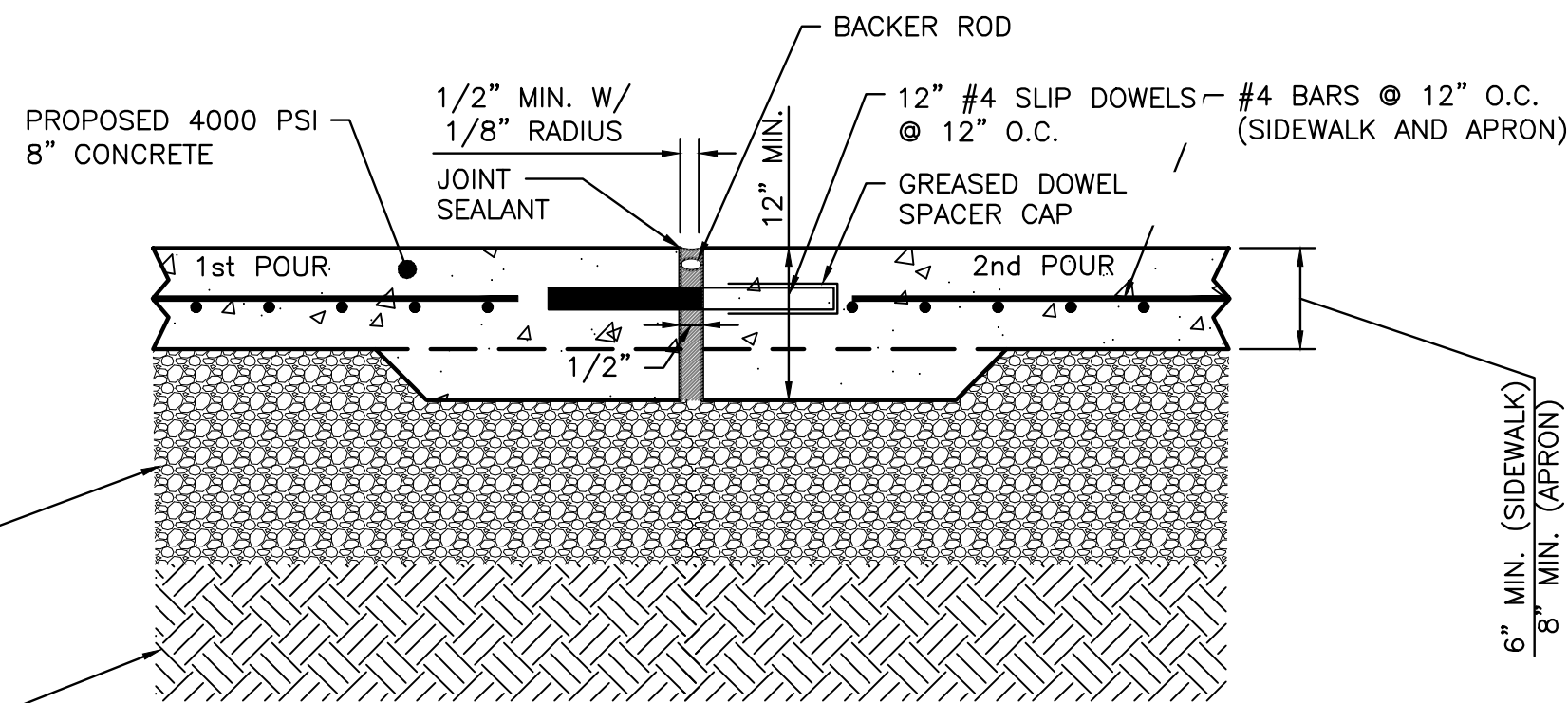

EXPANSION JOINT DETAIL
N.T.S.

- NOTES:**
1. EXPANSION JOINT MATERIAL MUST MEET ALDOT SPECIFICATION 832.01 & 832.02.
 2. JOINT FILLER TO BE CUT FLUSH WITH SIDEWALK SURFACE WHEN NO JOINT SEALER IS USED.

CONCRETE SIDEWALK AND APRON PAVING JOINT DETAILS
N.T.S.

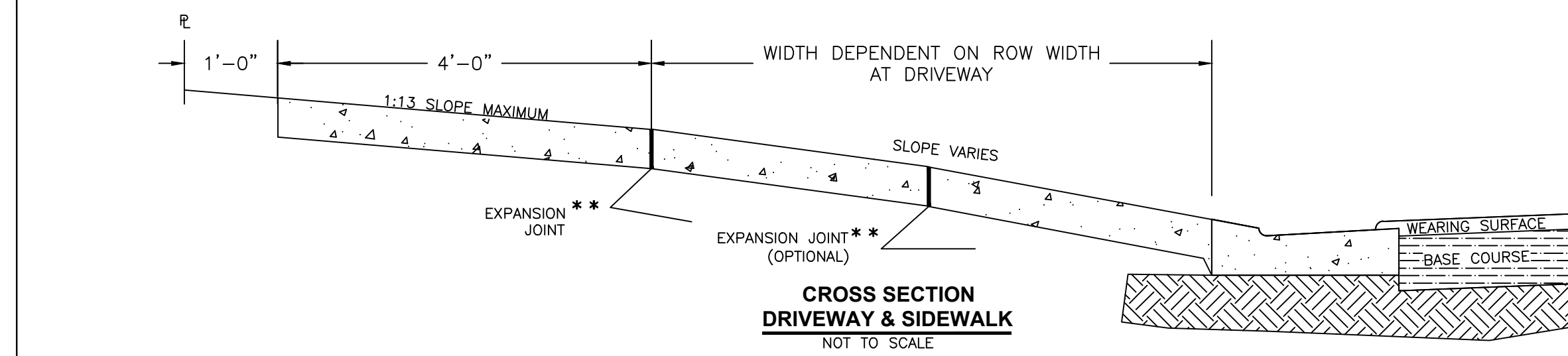

CROSS SECTION DRIVEWAY & SIDEWALK
NOT TO SCALE

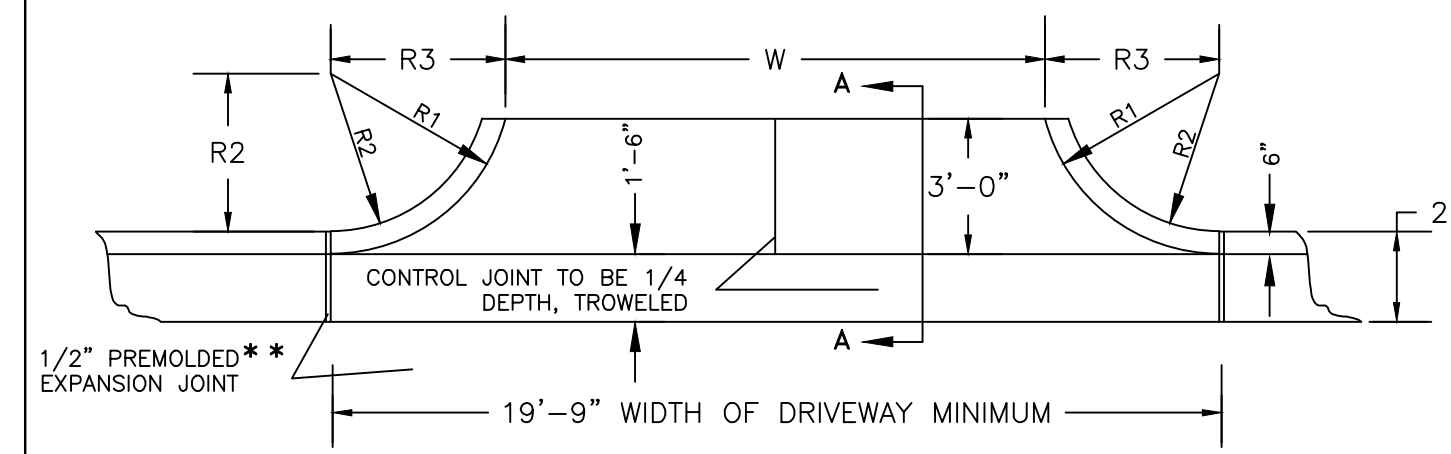

PLAN VIEW CONCRETE DRIVEWAY APRON
NOT TO SCALE

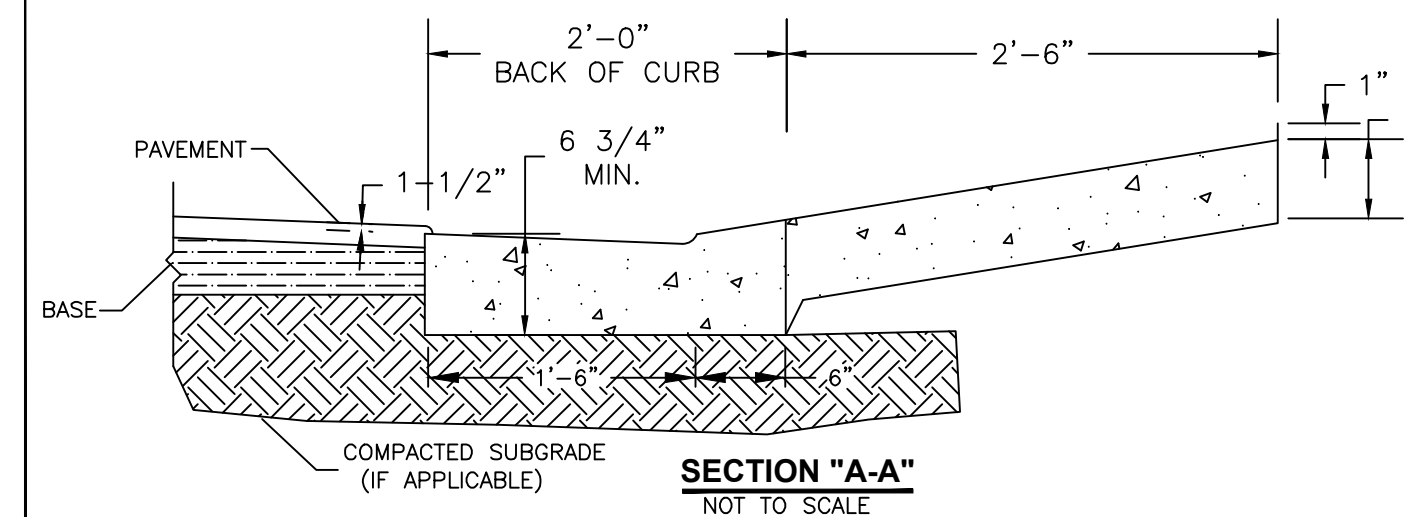

SECTION 'A-A'
NOT TO SCALE

	MINIMUM*	TYPE
R1	20'	COMMERCIAL
R2	19.5'	COMMERCIAL
R3	20'	COMMERCIAL
R1	4'	RESIDENTIAL
R2	3.5'	RESIDENTIAL
R3	3'-10.5"	RESIDENTIAL
W	24'	COMMERCIAL
W	12'	RESIDENTIAL

* IF SITE CONDITIONS PROHIBIT THE USE OF THESE STANDARDS, AN ALTERNATIVE MAY BE SUBMITTED FOR APPROVAL TO THE ENGINEERING DEPT.

** EXPANSION JOINT MATERIAL TO MEET ALDOT SPECIFICATIONS 832.01 & 832.02

NOTE: CONCRETE APRON AND DRIVEWAY TO BE 8" MINIMUM THICKNESS.

SIDEWALK PANELS THAT ABUT THE DRIVEWAY TO BE 6" MINIMUM THICKNESS.

OTHER SIDEWALK PANELS TO BE 6" MIN. THICKNESS.

ALL CONCRETE TO BE 4000 P.S.I. MIX WITH NATURAL COLOR AND BROOM FINISH.

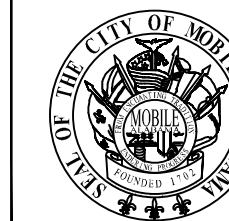

CITY OF MOBILE, ALABAMA ENGINEERING DEPARTMENT
CONCRETE DRIVEWAY & SIDEWALK DETAILS FOR ASPHALT ROADWAY W/CURB & GUTTER

STANDARD DRAWING 3 SHEET 1 OF 2 11-03-2009

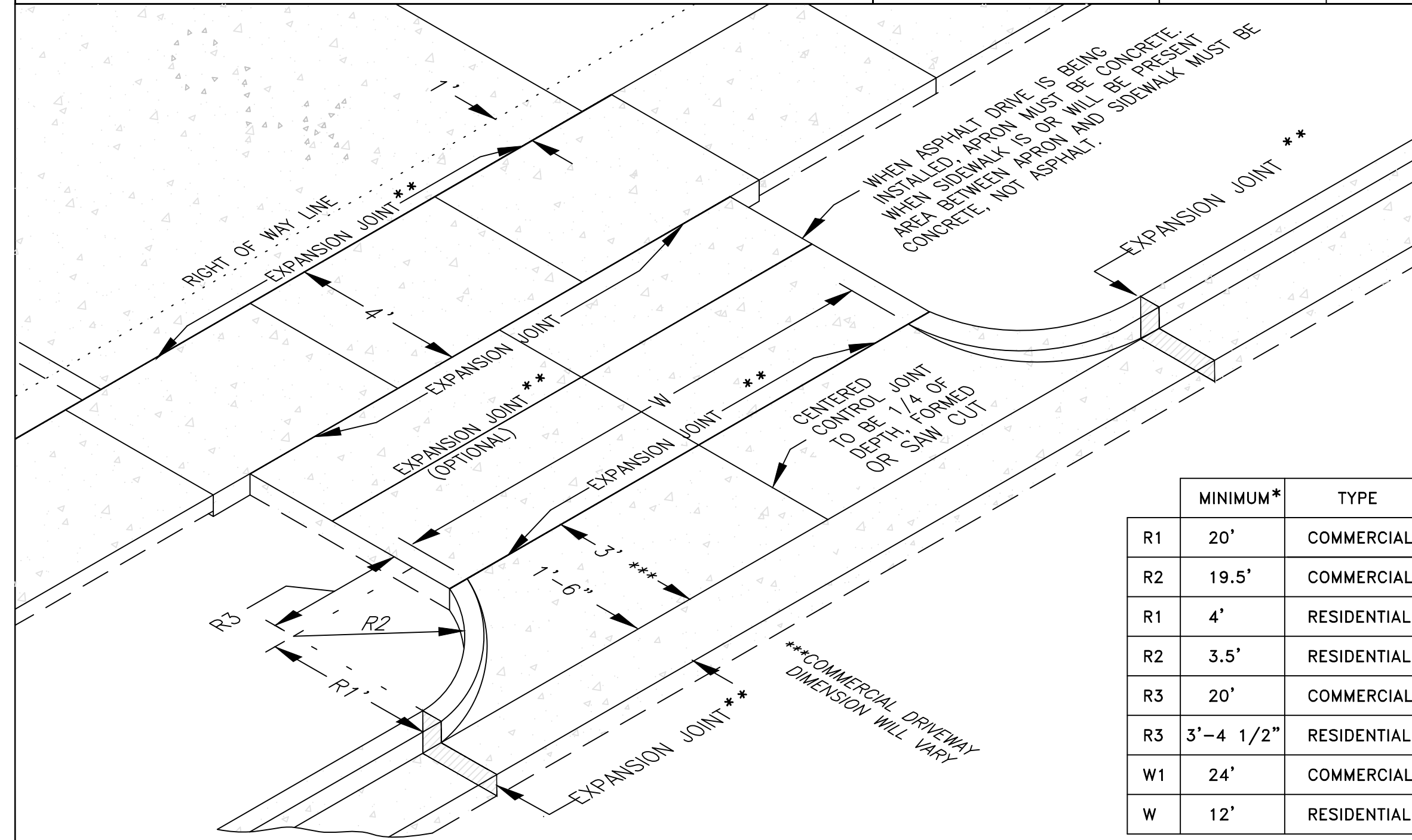

	MINIMUM*	TYPE
R1	20'	COMMERCIAL
R2	19.5'	COMMERCIAL
R1	4'	RESIDENTIAL
R2	3.5'	RESIDENTIAL
R3	20'	COMMERCIAL
R3	3'-4 1/2"	RESIDENTIAL
W1	24'	COMMERCIAL
W	12'	RESIDENTIAL

NOTES: CONCRETE APRON AND DRIVEWAY TO BE 8" MIN. THICKNESS. ALL SIDEWALK PANELS TO BE 6" MIN. THICKNESS WITH 4,000 PSI MIX WITH NATURAL COLOR AND BROOM FINISH.

* IF SITE CONDITIONS PROHIBIT THE USE OF THESE STANDARDS, AN ALTERNATIVE MAY BE SUBMITTED FOR APPROVAL TO THE ENGINEERING DEPT.

** EXPANSION JOINT MATERIAL TO MEET ALDOT SPECIFICATIONS 832.01 & 832.02

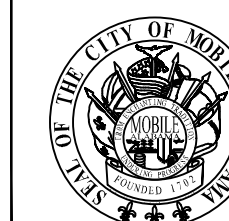

CITY OF MOBILE, ALABAMA ENGINEERING DEPARTMENT
CONCRETE DRIVEWAY DETAIL FOR ASPHALT ROADWAY W/CURB & GUTTER STREET

STANDARD DRAWING 3 SHEET 2 OF 2 05-26-10

P:\2021\Projects\1101\21-1101-0232 Coal Crichton Fire Station Apron Repairs Working Civil Drawings

THIS DRAWING REPRESENTS DESIGNS PREPARED BY THOMPSON ENGINEERING FOR SPECIFIC USE ON THIS PROJECT AND IS NOT TO BE COPIED, REPRODUCED, OR ALTERED WITHOUT THE EXPRESS WRITTEN CONSENT OF THE THOMPSON ENGINEERING REPRESENTATIVE AUTHORIZED TO APPROVE THIS USE. UNAUTHORIZED USE IS SUBJECT TO LEGAL ACTION UNDER STATE AND FEDERAL LAW.

REVISION NO.	DESCRIPTION	DATE	BY:
A	ISSUED FOR APPROVAL	12/7/21	FL
O	ISSUED FOR BID	12/20/21	FL



CITY OF MOBILE
MOBILE, ALABAMA

thompson ENGINEERING

2970 COTTAGE HILL RD., STE. 190
MOBILE, ALABAMA 36606

TEL: (251) 666-2443
FAX: (251) 666-6422

SCALE: 1:1 PLOT SCALE: DRAWN BY: BC CHECKED BY: SM APPROVED BY: FL DATE: FEBRUARY 4, 2022

CITY OF MOBILE
CRICHTON FIRE STATION
DRIVE REPAIR

DETAIL SHEET

JOB NO.: 21-1101-0232 DRAWING NO.: C200 REVISION NO.: 0

P:\2021\Projects\1101\21-1101-0232 CoM Crichton Fire Station Apron Repairs\Working\Civil\Drawings

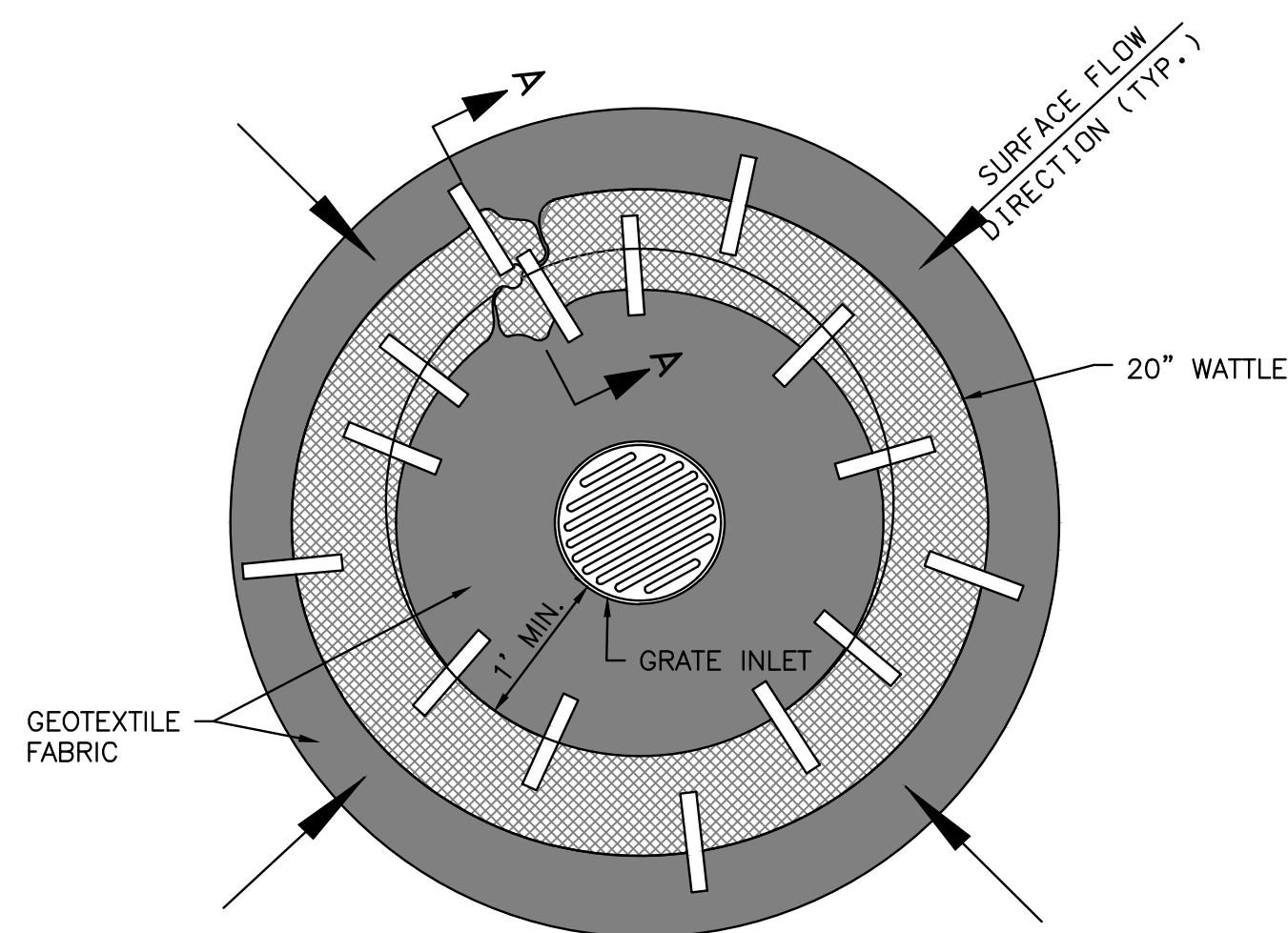

PLAN VIEW

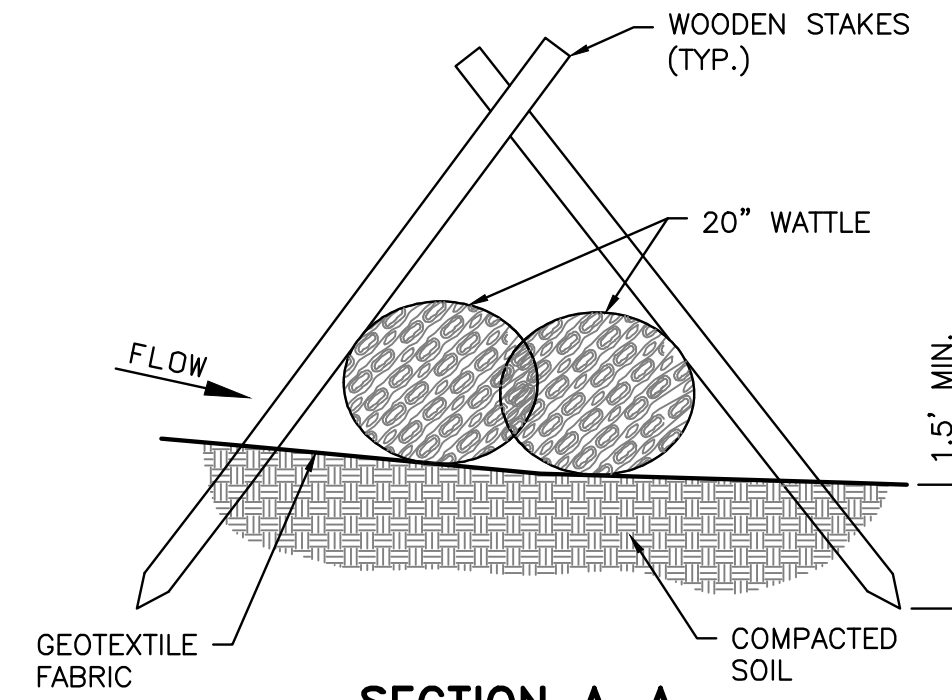
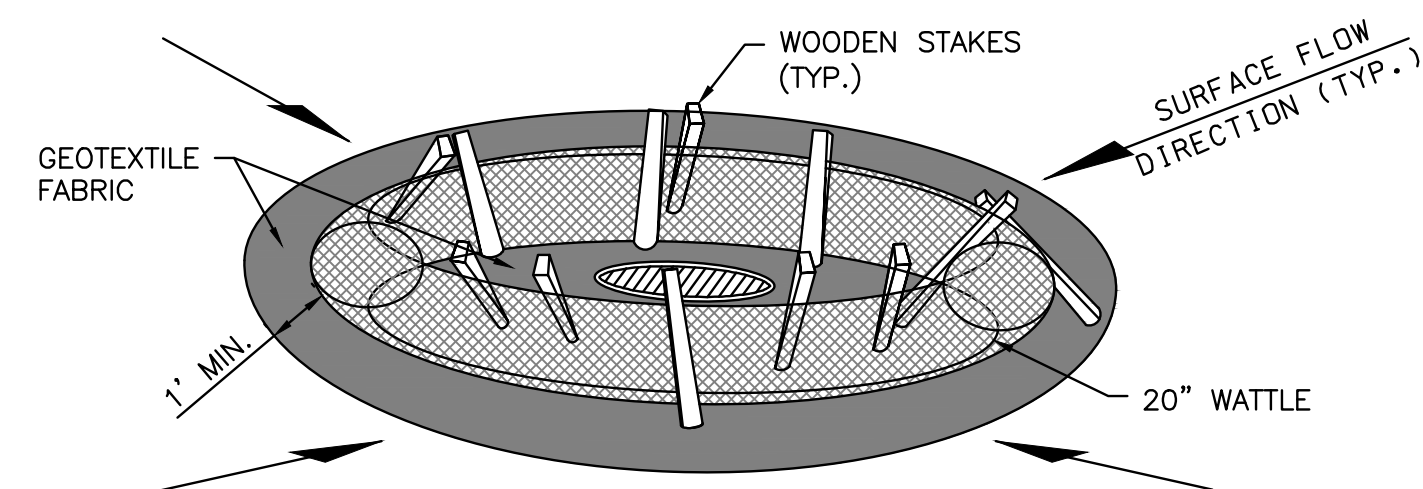

SECTION A-A

NOTES:

1. GEOTEXTILE FABRIC (8 OZ. NON-WOVEN) SHALL BE USED AS AN UNDERLAYMENT ON COMPACTED SOIL THAT EXTENDS FROM THE INLET TO A MINIMUM 1' BEYOND THE WATTLE. PIN GEOTEXTILE SECURELY AT THE INLET AND AROUND THE EDGE ON 5 INCH CENTERS.
2. USE A WATTLE THAT IS LESS POROUS TO ENSURE PONDING OCCURS. THE WATTLE SHALL BE PLACED IN A CIRCULAR SHAPE AT A MINIMUM OF 1' FROM THE INLET. THE WATTLE ENDS SHALL OVERLAP AT A MINIMUM OF 18" AND BE SECURED WITH GRADE STAKES OR HARDWOOD STAKES IN A T-PEE OR A-FRAME METHOD. THE STAKES SHALL BE AT A MINIMUM 2' ON CENTER.
3. TO PREVENT THE WATTLE FROM FLOATING THE CONTRACTOR SHALL SECURE THE WATTLE WITH SOD STAPLES ON EACH SIDE AT A MINIMUM OF 10" ON CENTER.

WATTLE INLET PROTECTION
N.T.S.

THIS DRAWING REPRESENTS DESIGNS PREPARED BY THOMPSON ENGINEERING FOR SPECIFIC USE ON THIS PROJECT AND IS NOT TO BE COPIED, REPRODUCED, OR ALTERED WITHOUT THE EXPRESS WRITTEN CONSENT OF THE THOMPSON ENGINEERING REPRESENTATIVE AUTHORIZED TO APPROVE THIS USE. UNAUTHORIZED USE IS SUBJECT TO LEGAL ACTION UNDER STATE AND FEDERAL LAW.

REVISION NO.	DESCRIPTION	DATE	BY:
A	ISSUED FOR APPROVAL	12/7/21	FL
0	ISSUED FOR BID	12/20/21	FL



CITY OF MOBILE
MOBILE, ALABAMA

thompson
ENGINEERING

2970 COTTAGE HILL RD., STE. 190
MOBILE, ALABAMA 36606

TEL: (251) 666-2443
FAX: (251) 666-6422

SCALE:	PLOT SCALE:	DRAWN BY:	CHECKED BY:	APPROVED BY:	DATE:	JOB NO.:	DRAWING NO.:	REVISION NO.:
	1:1	BC	SM	FL	FEBRUARY 4, 2022	21-1101-0232	C201	0

CITY OF MOBILE
CRICHTON FIRE STATION
DRIVE REPAIR

DETAIL SHEET